



# Chunghwa Picture Tubes, Ltd. Product Specification

To :

Date : 110111

**TFT LCD**

**CLAA104XA02CW**

ACCEPTED BY : (V0.1)

APPROVED BY	CHECKED BY	PREPARED BY
張聖暉	李家銘	張瑋霖

Prepared by :

Product Planning Management Division  
Small & Medium TFT Product Business Unit  
**CHUNGHWA PICTURE TUBES, LTD.**

1127 Hopin Rd., Padeh, Taoyuan, Taiwan 334, R.O.C.  
TEL: +886-3-3675151 FAX: +886-3-377-3858

Doc.No:	SPEC_CLAA104XA02CW_V0.1_110111	Issue Date	2010/11/30
---------	--------------------------------	------------	------------

**REVISION STATUS**

Revision Notice	Description	Page	Rev. Date
Ver. 0.0	First revision (Tentative)	-	2010.11.12
Ver. 0.1	Revise NTSC	11	2010.11.29
	Revise Image Sticking	16	2010.11.29

## CONTENTS

<b>1. OVERVIEW</b> .....	<b>4</b>
<b>2. ABSOLUTE MAXIMUM RATINGS</b> .....	<b>5</b>
<b>3. ELECTRICAL CHARACTERISTICS</b> .....	<b>6</b>
3.1 TFT LCD Power Voltage .....	6
3.2 TFT-LCD Current Consumption .....	7
3.3 Power 、 Signal sequence.....	7
3.4 BACKLIGHT: .....	8
<b>4. INTERFACE CONNECTION</b> .....	<b>9</b>
<b>5. INPUT SIGNAL(DE ONLY MODE)</b> .....	<b>10</b>
5.1 Timing Specification.....	10
5.2 Timing sequence (Timing chart) .....	10
5.3 Color data assignment.....	12
<b>6. MECHANICAL DIMENSION</b> .....	<b>13</b>
6.1 Front Side .....	13
6.2 Rear Side.....	13
<b>7. OPTICAL CHARACTERISTICS</b> .....	<b>14</b>
<b>8. RELIABILITY TEST</b> .....	<b>16</b>
8.1. Temperature and humidity .....	16
8.2. Shock and Vibration.....	16
8.3 Electrostatic Discharge .....	16
8.4. Judgment standard .....	17

## 1. OVERVIEW

CLAA104XA02CW is 10.4" color TFT-LCD (Thin Film Transistor Liquid Crystal Display) module composed of LCD panel, driver ICs, control circuit, and backlight.

The 10.4" screen produces a high resolution image that is composed of 1024×768 pixel elements in a stripe arrangement. Display 262K colors by 6 Bit R.G.B signal input.

General specification are summarized in the following table:

ITEM	SPECIFICATION
Panel Size	10.4 inch(panel diagonal)
Display Area (mm)	211.2(H)×158.4(V) (10.4-inch diagonal)
Number of Pixels	1024(H) × 3(RGB) × 768(V)
Pixel Pitch (mm)	0.20625 x0. 20625
Color Pixel Arrangement	RGB vertical stripe
Display Mode	Normally white
Number of colors	262,144
Brightness(cd/m <sup>2</sup> )	400(typ.)
Response Time (Tr+Tf)	25 ms
Module Size (mm)	236(W)×174.3(H)×7.4(D) (with PWB and component)
Viewin Angle(BL on,CR≥10)	140 degree(H) · 120 degree(V)
Power consumption ( W )	4.3W
BL unit	LED
Electrical Interface(data)	LVDS
Viewing Direction	6 o'clock (Max contrast ratio, Gray Level Inversion)
Weight(g)	TBD
Surface Treatment	Anti-Glare · Hardness:3H

## 2. ABSOLUTE MAXIMUM RATINGS

The following are maximum values which, if exceeded, may cause faulty operation or damage to the unit.

ITEM	SYMBOL	MIN.	MAX.	UNIT	NOTE
Power Supply Voltage	V <sub>cc</sub>	-0.3	4.0	V	
LED Supply Voltage	V <sub>LED</sub>		10.65	V	
ICC Rush Current	IRUSH	-	1	A	【Note 2】
Operation Temperature	T <sub>op</sub>	-20	70	°C	【Note 1】
Storage Temperature	T <sub>stg</sub>	-30	80	°C	【Note 1】

**【Note】**

**【Note1】** If users use the product out off the environment operation range ( temperature and humidity ) ,it will concern for visual quality.

**【Note2】** The input pulse-current measurement system as below :

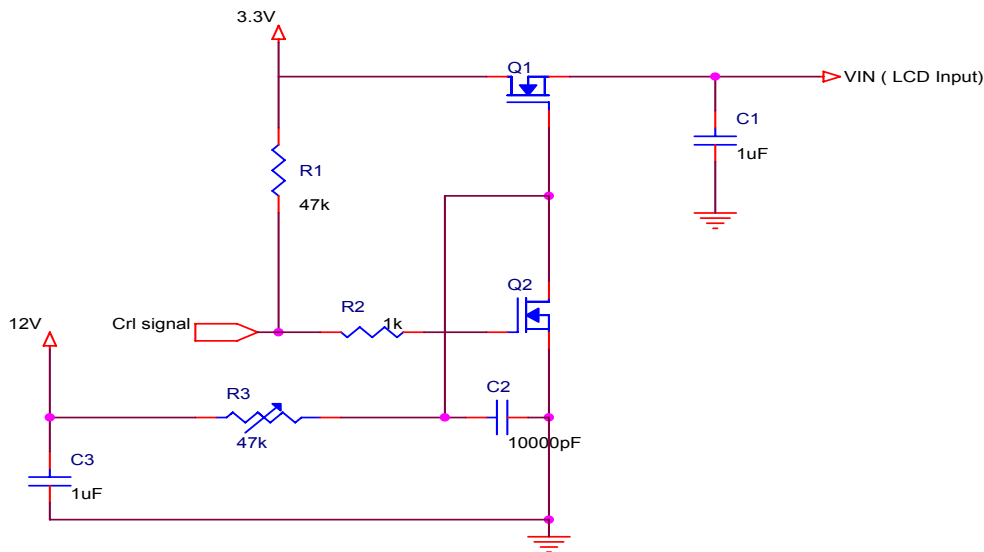

Control signal: High(+3.3V)→Low(GND)

Supply Voltage of rising time should be from R3 and C2 tune to 550 us.

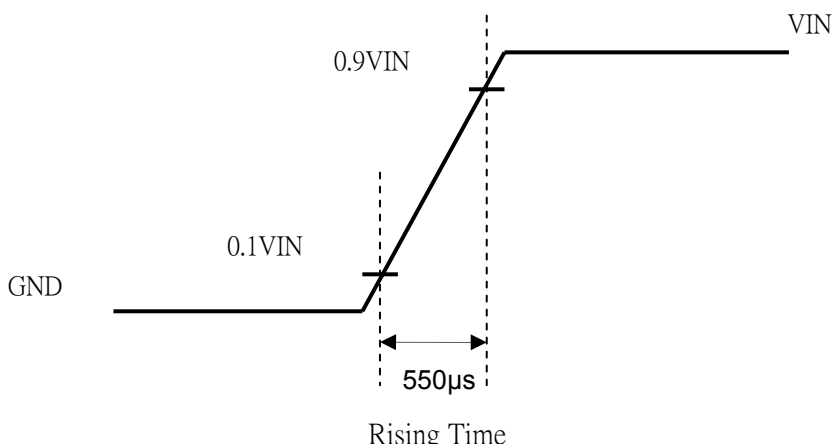

### 3. ELECTRICAL CHARACTERISTICS

#### 3.1 TFT LCD Power Voltage

Ta=25°C

ITEM	SYMBOL	MIN.	TYP.	MAX.	UNIT	NOTE	
Power Supply Voltage For LCD	V <sub>CC</sub>	3.0	3.3	3.6	V	【Note 1】	
Logic Input Voltage (LVDS:IN+,IN-)	Common Mode Voltage	V <sub>CM</sub>	1.08	1.2	1.32	V	【Note 2】
	Differential Input Voltage	V <sub>ID</sub>	250	350	450	mV	【Note 2】
	Threshold Voltage(high)	V <sub>TH</sub>	-	-	100	mV	【Note 2】
	Threshold Voltage(low)	V <sub>TL</sub>	-100	-	-	mV	【Note 2】

Remarks :

【Note1】 VCC –dip condition:

- 1) When  $2.7\text{ V} \leq V_{CC} < 3.0\text{V}$  ,  $t_d \leq 10\text{ms}$ .
- 2)  $V_{CC} > 3.0\text{V}$  , VCC-dip condition should be same as VCC-turn-on condition.

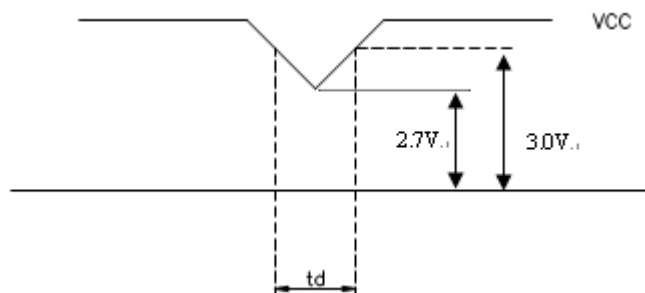

【Note 2】 LVDS signal

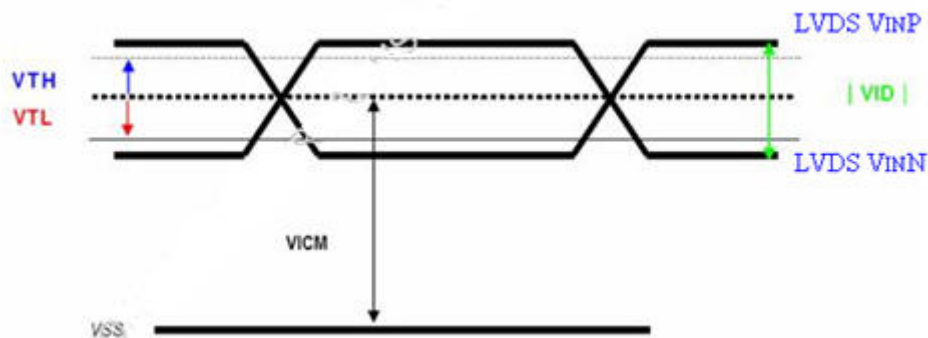

### 3.2 TFT-LCD Current Consumption

ITEM	SYMBOL	MIN.	TYP.	MAX.	UNIT	NOTE
LCD Power Current	$I_{CC}$	--	450	500	mA	【Note1】

【Note1】 (Frame rate = 60 Hz)

Typical: Under 64 gray pattern @  $V_{CC} = 3.3\text{ V}$

Maximum: Under black pattern @  $V_{CC} = 3.0\text{ V}$



(a) 64 Gray Pattern



(b) Black Pattern

### 3.3 Power & Signal sequence

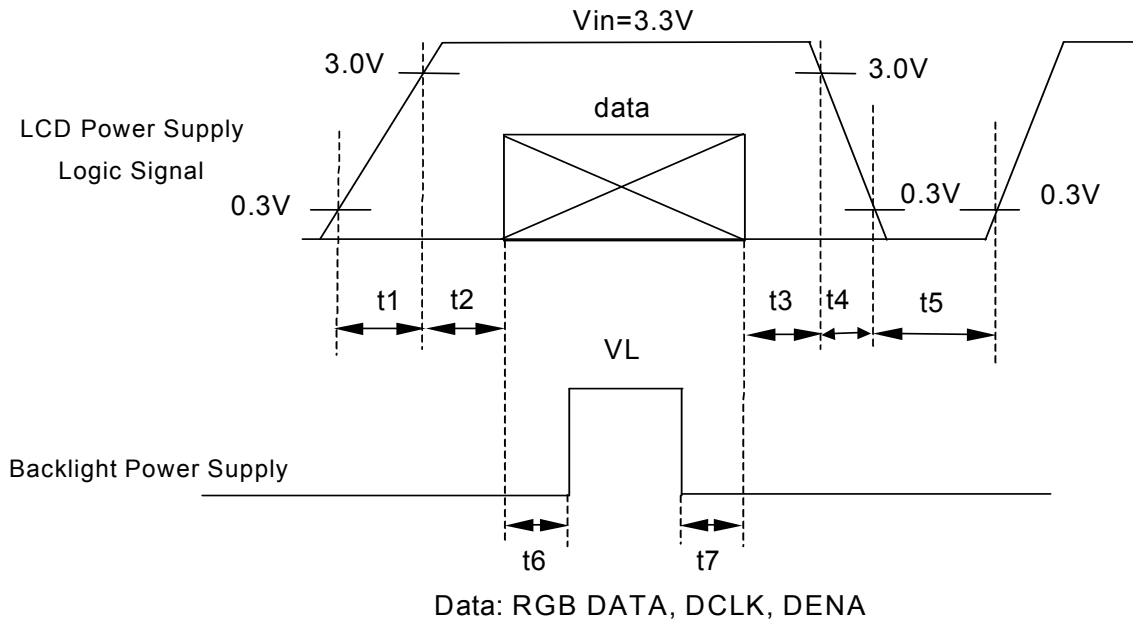

- |                             |                        |
|-----------------------------|------------------------|
| $0.5 < t1 \leq 10\text{ms}$ | $200\text{ms} \leq t5$ |
| $0 < t2 \leq 50\text{ms}$   | $200\text{ms} \leq t6$ |
| $0 < t3 \leq 50\text{ms}$   | $200\text{ms} \leq t7$ |
| $0 < t4 \leq 10\text{ms}$   |                        |

3.4 BACKLIGHT:

ITEM	SYMBOL	CONDITION	MIN	TYP	MAX	UNIT	REMARKS
LED current	IL	Ta=25°C (20mA/serise)	--	260	--	mA	Note 1,2
LED voltage	VL	Ta=25°C (20mA/serise)	8.85	9.6	10.65	V	Note 1,2
Power consumption	WL	Ta=25°C (20mA/serise)	--	2.496	--	W	Note 1,2
LED Lifetime	-	Ta=25°C IF=20mA	30000	-	-	Hr	Note 3,4,5

Remarks :

\*1)LED Circuit Diagram :

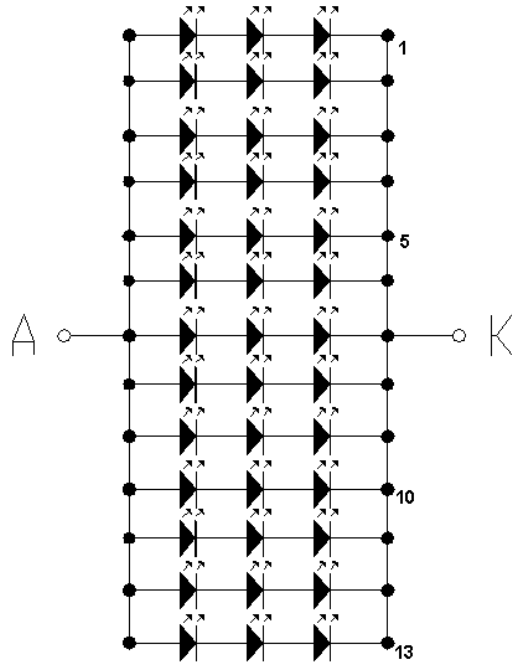

\*2) A : Anode(+) , K : Cathode(-)

\*3) Suggestion: Using the constant current control to avoid the leakage light and brightness quality issue.

\*4) DEFINITION OF LED LIFETIME : LUMINANCE < INITIAL LUMINANCE 50%

\*5) Ifp Conditions : Pulse Width ≤ 10msec , Duty ≤ 1/10 °  
One of every LED must be satisfied as below figure.

Forward Current vs.  
Ambient Temperature

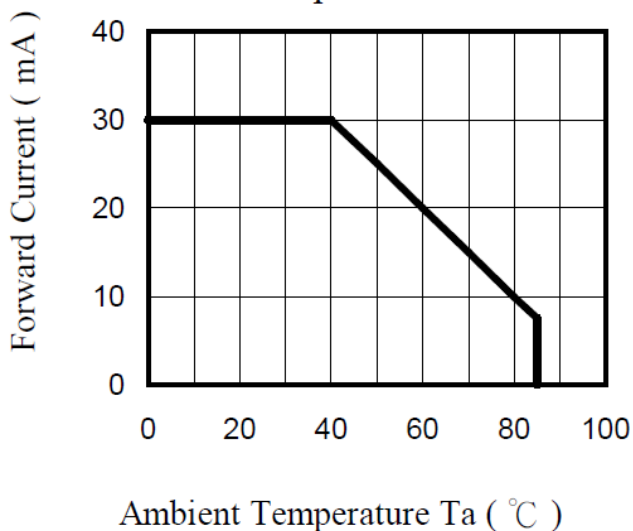



## 4. INTERFACE CONNECTION

LCD connector (30pin) : STARCONN · P/N : MSBK2407P30D or other of the same class

Pin No.	SYMBOL	FUNCTION
1	GND	Ground
2	V <sub>CC</sub>	+3.3V Power
3	V <sub>CC</sub>	+3.3V Power
4	NC	NC
5	NC	NC
6	NC	NC
7	GND	GND
8	RXIN0-	LVDS Signal(-)—channel 0
9	RXIN0+	LVDS Signal(+)—channel 0
10	GND	Ground
11	RXIN1-	LVDS Signal(-)—channel 1
12	RXIN1+	LVDS Signal(+)—channel 1
13	GND	Ground
14	RXIN2-	LVDS Signal(-)—channel 2
15	RXIN2+	LVDS Signal(+)—channel 2
16	GND	Ground
17	RXCLKIN-	LVDS Clock Signal(-)
18	RXCLKIN+	LVDS Clock Signal(+)
19	GND	Ground
20	NC	NC
21	NC	NC
22	GND	Ground
23	GND	Ground
24	NC	NC
25	NC	NC
26	NC	NC
27	NC	NC
28	NC	NC
29	NC	NC
30	NC	NC

### 【Note】

- 1) GND Pin must be connected to ground. Don't be floating.
- 2) NC Pin must be floating.

## 5. INPUT SIGNAL(DE ONLY MODE)

### 5.1 Timing Specification

ITEM		SYMBOL	MIN.	TYP.	MAX.	UNIT	
LVDS input signal sequence	CLK Frequency	fCLKin	51	65	71	MHz	
LCD input timing	Horizontal	Horizontal Period	$t_H$	1160	1344	1350	tCLK
		Horizontal Valid	$t_{HA}$	1024			tCLK
		Horizontal Blank	$t_{HB}$	136	320	326	tCLK
	Vertical	Frame	fV	55	60	65	Hz
		Vertical Period	$t_V$	790	806	810	$t_H$
		Vertical Valid	$t_{VA}$	768			$t_H$
	Vertical Blank	$t_{VB}$	22	38	42	$t_H$	

### 5.2 Timing sequence (Timing chart)

#### 5.2.1 Horizontal Timing Sequence

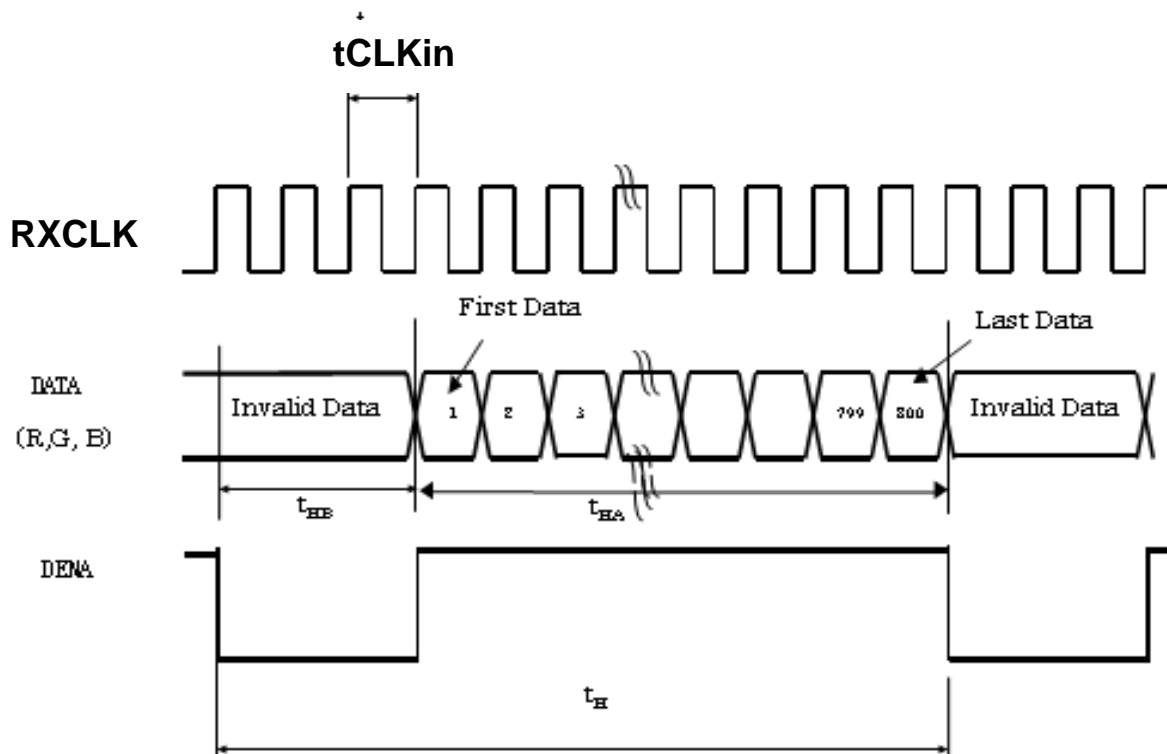

### 5.2.2 Vertical Timing Sequence

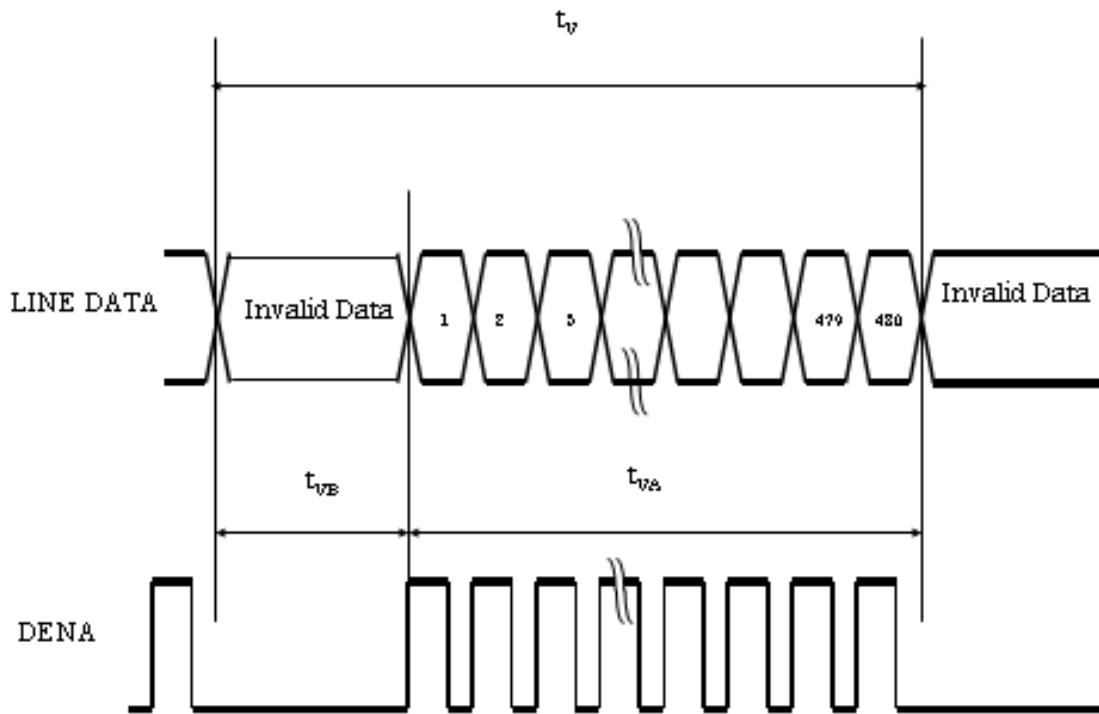

### 5.2.3 LVDS Input Data mapping

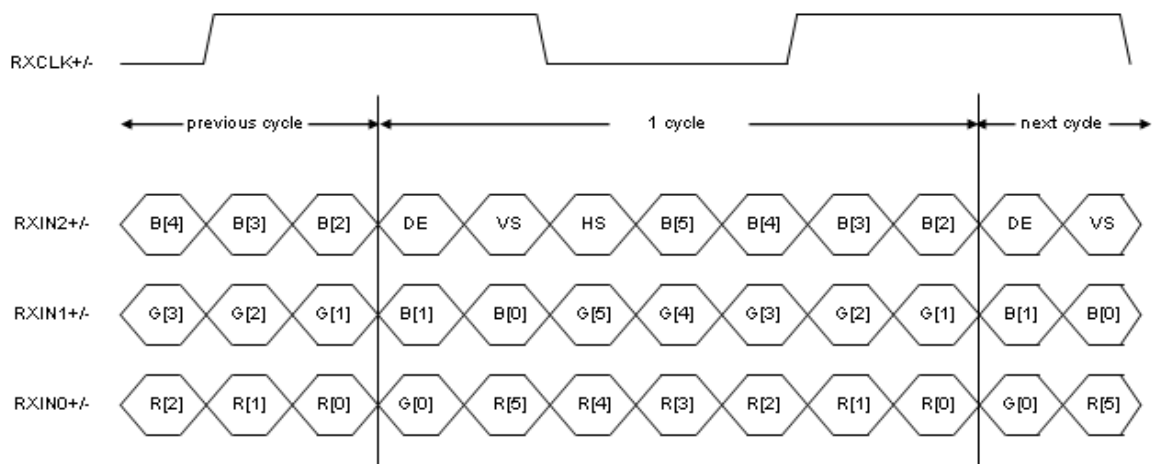

5.3 Color data assignment

COLOR	INPUT	R DATA						G DATA						B DATA					
	DATA	R5	R4	R3	R2	R1	R0	G5	G4	G3	G2	G1	G0	B5	B4	B3	B2	B1	B0
		MSB					LSB	MSB					LSB	MSB					LSB
BASIC COLOR	BLACK	0	0	0	0	0	0	0	0	0	0	0	0	0	0	0	0	0	0
	RED(63)	1	1	1	1	1	1	0	0	0	0	0	0	0	0	0	0	0	0
	GREEN(63)	0	0	0	0	0	0	1	1	1	1	1	1	0	0	0	0	0	0
	BLUE(63)	0	0	0	0	0	0	0	0	0	0	0	0	1	1	1	1	1	1
	CYAN	0	0	0	0	0	0	1	1	1	1	1	1	1	1	1	1	1	1
	MAGENTA	1	1	1	1	1	1	0	0	0	0	0	0	1	1	1	1	1	1
	YELLOW	1	1	1	1	1	1	1	1	1	1	1	1	0	0	0	0	0	0
	WHITE	1	1	1	1	1	1	1	1	1	1	1	1	1	1	1	1	1	1
RED	RED(0)	0	0	0	0	0	0	0	0	0	0	0	0	0	0	0	0	0	0
	RED(1)	0	0	0	0	0	1	0	0	0	0	0	0	0	0	0	0	0	0
	RED(2)	0	0	0	0	1	0	0	0	0	0	0	0	0	0	0	0	0	0
	RED(62)	1	1	1	1	1	0	0	0	0	0	0	0	0	0	0	0	0	0
	RED(63)	1	1	1	1	1	1	0	0	0	0	0	0	0	0	0	0	0	0
GREEN	GREEN(0)	0	0	0	0	0	0	0	0	0	0	0	0	0	0	0	0	0	0
	GREEN(1)	0	0	0	0	0	0	0	0	0	0	1	0	0	0	0	0	0	0
	GREEN(2)	0	0	0	0	0	0	0	0	0	1	0	0	0	0	0	0	0	0
	GREEN(62)	0	0	0	0	0	0	1	1	1	1	1	0	0	0	0	0	0	0
	GREEN(63)	0	0	0	0	0	0	1	1	1	1	1	1	0	0	0	0	0	0
BLUE	BLUE(0)	0	0	0	0	0	0	0	0	0	0	0	0	0	0	0	0	0	0
	BLUE(1)	0	0	0	0	0	0	0	0	0	0	0	0	0	0	0	0	0	1
	BLUE(2)	0	0	0	0	0	0	0	0	0	0	0	0	0	0	0	0	1	0
	BLUE(62)	0	0	0	0	0	0	0	0	0	0	0	0	1	1	1	1	1	0
	BLUE(63)	0	0	0	0	0	0	0	0	0	0	0	0	1	1	1	1	1	1

【Note1】 Definition of Gray Scale

color(n) : (n) means the level of gray scale, the larger (n) means the brighter level.

【Note2】 Data:1-High,0-Low

### 6. MECHANICAL DIMENSION

#### 6.1 Front Side

[Unit : mm]

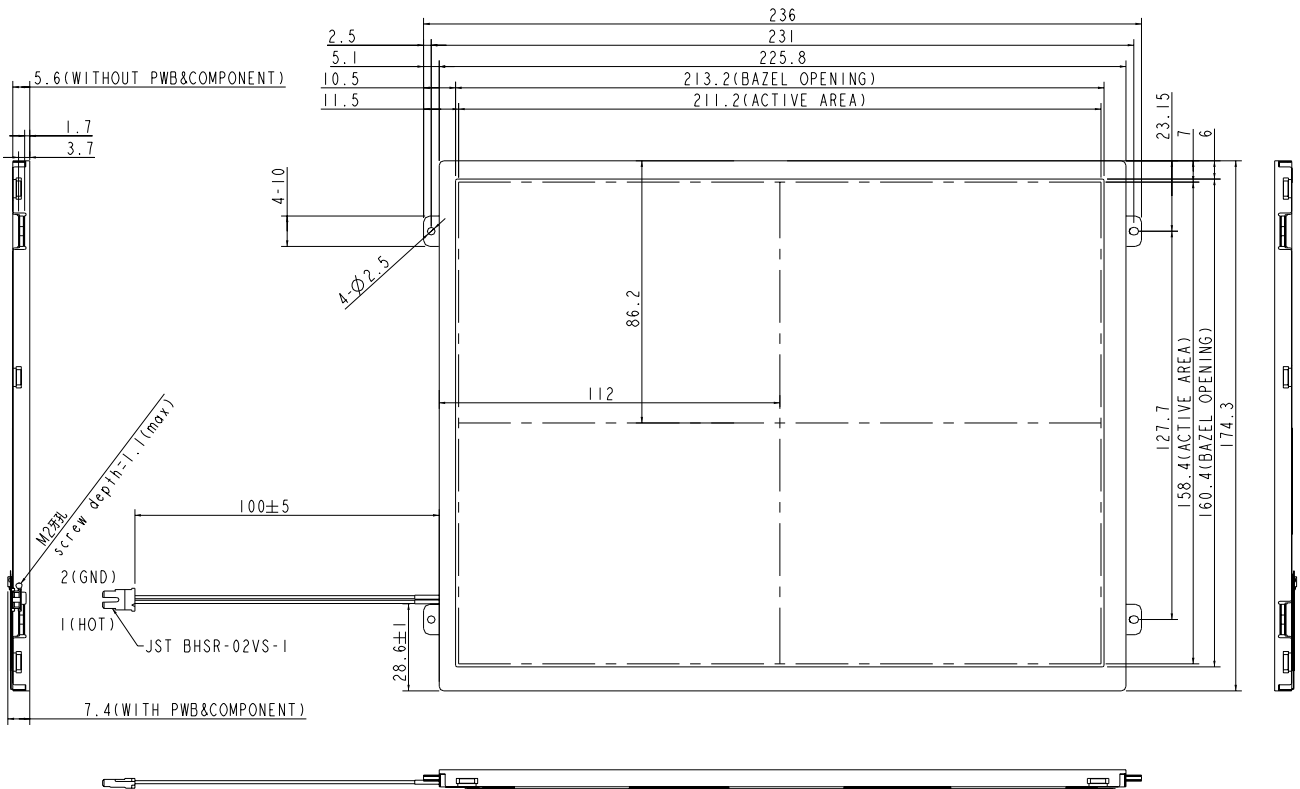

[Note] : Tolerance is  $\pm 0.3\text{mm}$  unless noted

#### 6.2 Rear Side

[Unit : mm]

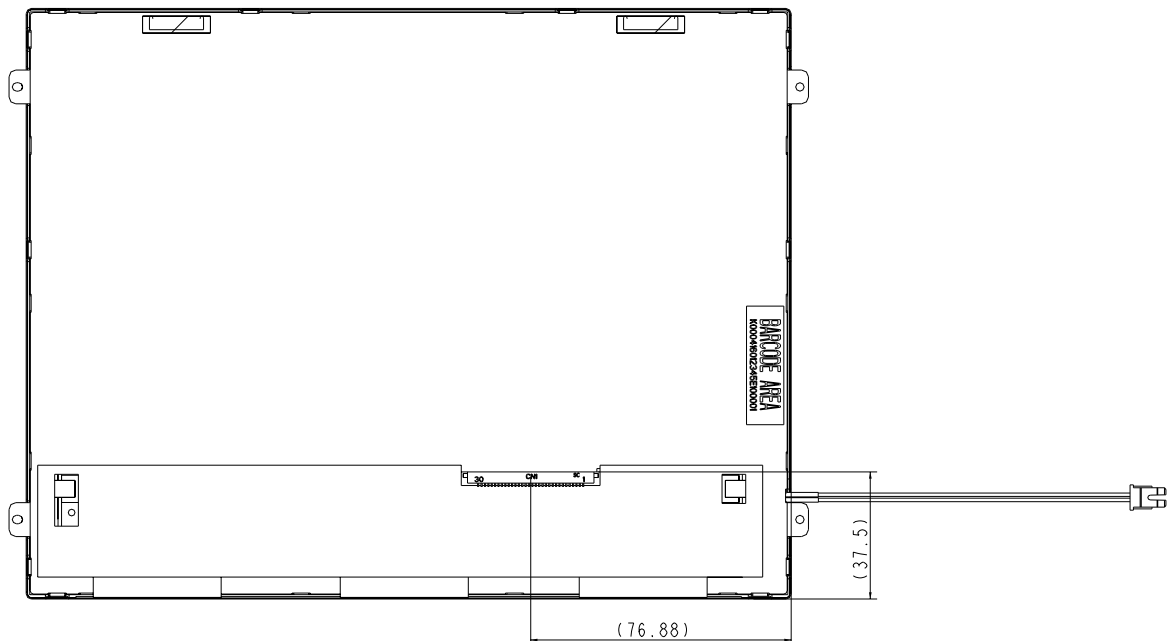

[Note] : Tolerance is  $\pm 0.3\text{mm}$  unless noted

## 7. OPTICAL CHARACTERISTICS

 $T_a = 25^{\circ}\text{C}, V_{CC}$   
 $= 3.3\text{V}$ 

ITEM	SYMBOL	CONDITION	MIN.	TYP.	MAX.	UNIT	NOTE	
Constrast Ratio	CR	Point-5	400	500	--	--	*1)*2)*3)	
Luminance*)	Lw	Point-5	350	400	--	cd/m <sup>2</sup>	*1)*3)	
Luminance Uniformity	$\Delta L$		70	80		%	*1)*3)	
Response Time (White - Black)	Tr+ Tf	Point-5		25	30	ms	*1)*3)*5)	
Viewing Angle	Horizontal	$\psi$	CR $\geq$ 10 Point-5	140	--	$^{\circ}$	*1)*2)*4)	
	Vertical	$\theta$		120	--	$^{\circ}$	*1)*2)*4)	
NTSC				(50)	--	%		
Color Coordinate	White	Wx Wy	$\theta = \phi = 0^{\circ}$ Point-5	0.273 0.289	0.313 0.329	0.353 0.369	--	*1)*3)
	Red	Rx Ry			TBD			
	Green	Gx Gy			TBD			
	Blue	Bx By			TBD			

NOTE :

\*1) Measure condition :  $25^{\circ}\text{C} \pm 2^{\circ}\text{C}$  ,  $60 \pm 10\% \text{RH}$  , under 10 Lux in the dark room. BM-5A (TOPCON) , viewing angle  $2^{\circ}$  ,  $V_{adj} = 3.3\text{V}$  Duty 100% or  $I_L = 260\text{mA}$  , after 10 minutes operation.

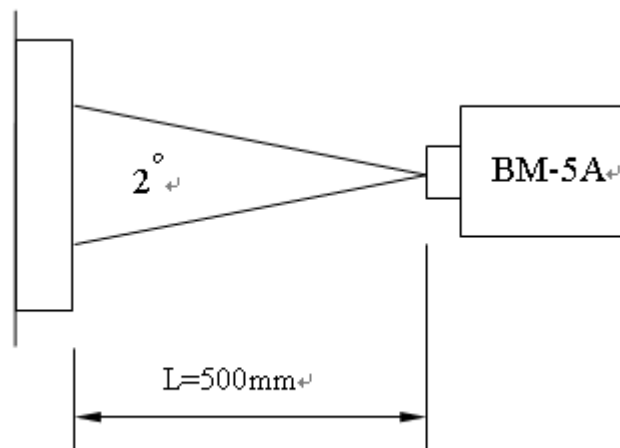

\*2) Definition of contrast ratio :

$$\text{Contrast Ratio (CR)} = (\text{White}) \text{ Luminance of ON} \div (\text{Black}) \text{ Luminance of OFF}$$

- 3) Definition of luminance : Measure white luminance on the point 5 as figure8-1  
 Definition of Luminance Uniformity: Measure white luminance on the point1~9 as figure8-1  
 $\Delta L = [L(\text{MIN})/L(\text{MAX})] \times 100$

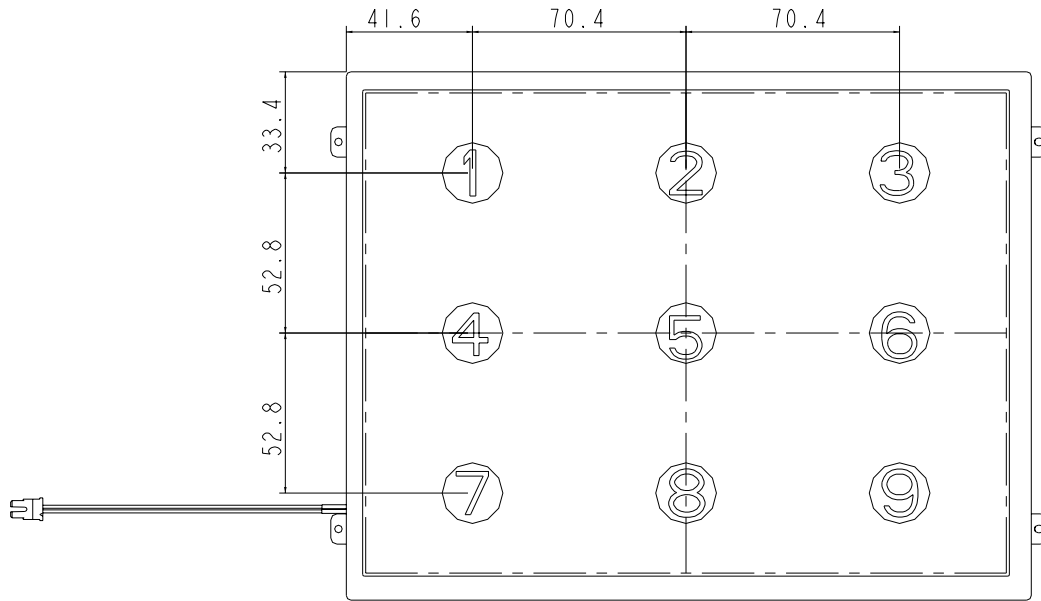

Fig8-1 Measuring point

- \*4) Definition of Viewing Angle( $\theta, \psi$ ), refer to Fig8-2 as below :  
 These items are measured by EZ-CONTRAST (ELDIM) in the dark room. (no ambient light).

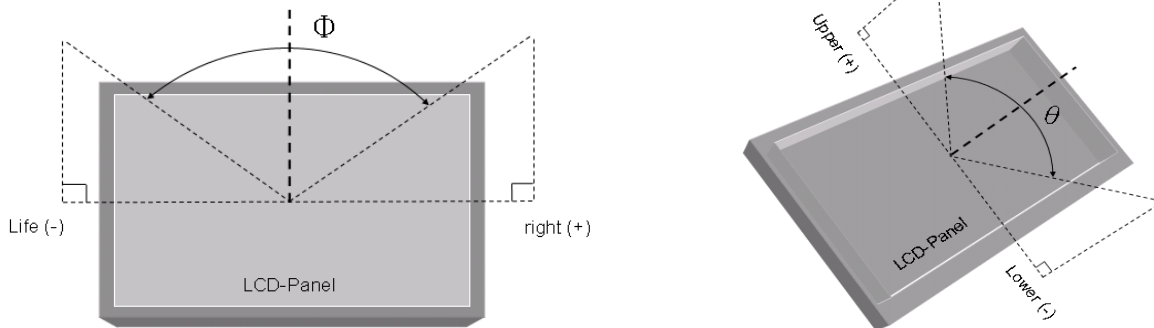

Fig8-2 Definition of Viewing Angle

- \*5) Definition of Response Time.(White-Black)

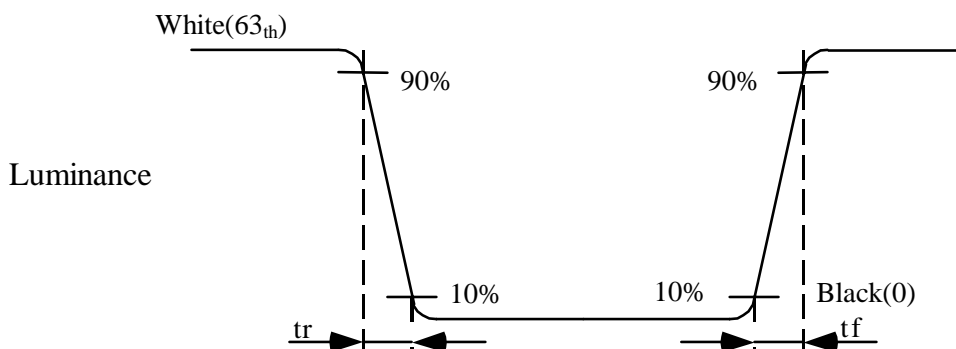

Fig8-3 Definition of Response Time(White-Black)

## 8. RELIABILITY TEST

### 8.1. Temperature and humidity

TEST ITEMS	CONDITIONS	NOTE
High Temperature Operation	70°C , 240Hrs	
High Temperature Storage	80°C , 240Hrs	
High Temperature High Humidity Operation	60°C , 90%RH , 240Hrs	No condensation
Low Temperature Operation	-20°C , 240Hrs	
Low Temperature Storage	-30°C , 240Hrs	
Thermal Shock	-30°C ( 0.5Hr) ~ 80°C(0.5Hr) 200 cycles	
Image Sticking	25°C ; 4hrs	

Note :

Condition of Image Sticking test : 25 °C ± 2 °C

Operation with test pattern sustained for 4 hrs, then change to gray pattern immediately.

After 5 mins, the mura must be disappeared completely .

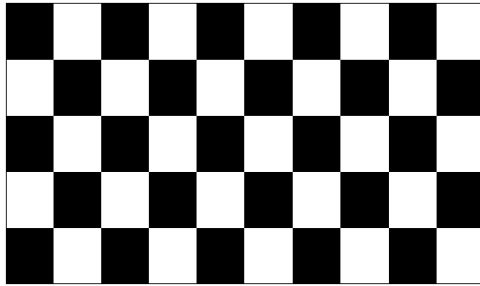

### 8.2. Shock and Vibration

TEST ITEMS	CONDITIONS
Shock (Non-operation)	<ul style="list-style-type: none"> <li>● Shock level:980m/s<sup>2</sup>(equal to 100G)</li> <li>● Waveform:half sinusoidal wave,6ms.</li> <li>● Number of shocks:one shock input in each direction of three mutually perpendicular axes for a total of three shock inputs.</li> </ul>
Vibration (Non-operation)	<ul style="list-style-type: none"> <li>● Frequency range:8~33.3Hz</li> <li>● Stroke:1.3mm</li> <li>● Vibration:sinusoidal wave,perpendicularaxis(both x, z axis:2Hrs, y axis 4Hrs).</li> <li>● Sweep:2.9G,33.3Hz-400Hz</li> <li>● Cycle:15min</li> </ul>

### 8.3 Electrostatic Discharge

ITEM	CONDITION	NOTE
ESD	150pF , 330Ω , ±8kV&±15kV air & contact test	*1)
	200pF , 0Ω , ±200V contact test	*2)

Note: Measure

1: LCD glass and metal bezel

2: IF connector pins



#### 8.4. Judgment standard

The Judgment of the above test should be made as follow:

Pass:Normal display image with no obvious non-uniformity and no line defect.Partial transformation of the module parts should be ignored.

Fail:No display image,obvious non-uniform,or line defect.