



( ) Preliminary Specification  
(V) Final Specification

<b>Module</b>	17.3" FHD Color TFT-LCD
<b>Model Name</b>	G173HW01 V0

<b>Customer</b>	<b>Date</b>
_____	_____
<b>Approved by</b>	<b>Date</b>
_____	_____
Note: This Specification is subject to change without notice.	

<b>Checked &amp; Approved by</b>	<b>Date</b>
<u>Crystal Hsieh</u>	<u>2017/05/15</u>
<b>Prepared by</b>	
<u>Athena Wu</u>	<u>2017/05/15</u>
General Display Business Unit/ AU Optronics corporation	



## Contents

<b>1. Handling Precautions</b> .....	<b>4</b>
<b>2. General Description</b> .....	<b>5</b>
2.1 Display Characteristics .....	5
<b>3. Functional Block Diagram</b> .....	<b>10</b>
<b>4. Absolute Maximum Ratings</b> .....	<b>11</b>
4.1 Absolute Ratings of TFT LCD Module .....	11
4.2 Absolute Ratings of Environment .....	11
<b>5. Electrical characteristics</b> .....	<b>12</b>
5.1 TFT LCD Module .....	12
5.2 Backlight Unit.....	14
<b>6. Signal Characteristic</b> .....	<b>15</b>
6.1 Pixel Format Image .....	15
6.2 The Input Data Format .....	16
6.4 Interface Timing .....	19
6.5 Power ON/OFF Sequence.....	20
<b>7. Connector &amp; Pin Assignment</b> .....	<b>21</b>
7.1 TFT LCD Module .....	21
7.2 Backlight Unit.....	22
<b>8. Reliability Test</b> .....	<b>23</b>
<b>9. Label</b> .....	<b>24</b>
<b>9.1. Shipping Label</b> .....	<b>24</b>
<b>9.2. BLU Label</b> .....	<b>24</b>
<b>10. Packing Form</b> .....	<b>25</b>
10.1 Packaging material .....	25
10.2 External packaging material required .....	25
10.3 Palletizing sequence.....	26
10.4 Packing instruction .....	27
<b>11. Outline Drawing</b> .....	<b>28</b>



## 1. Handling Precautions

- 1) Since front polarizer is easily damaged, please be cautious and not to scratch it.
- 2) Be sure to turn off power supply when inserting or disconnecting from input connector.
- 3) Wipe off water drop immediately. Long contact with water may cause discoloration or spots.
- 4) When the panel surface is soiled, wipe it with absorbent cotton or soft cloth.
- 5) Since the panel is made of glass, it may be broken or cracked if dropped or bumped on hard surface.
- 6) To avoid ESD (Electro Static Discharge) damage, be sure to ground yourself before handling TFT-LCD Module.
- 7) Do not open nor modify the module assembly.
- 8) Do not press the reflector sheet at the back of the module to any direction.
- 9) In case if a module has to be put back into the packing container slot after it was taken out from the container, do not press the center of the LED light bar edge. Instead, press at the far ends of the LED light bar edge softly. Otherwise the TFT Module may be damaged.
- 10) At the insertion or removal of the Signal Interface Connector, be sure not to rotate nor tilt the Interface Connector of the TFT Module.
- 11) TFT-LCD Module is not allowed to be twisted & bent even force is added on module in a very short time. Please design your display product well to avoid external force applying to module by end-user directly.
- 12) Small amount of materials without flammability grade are used in the TFT-LCD module. The TFT-LCD module should be supplied by power complied with requirements of Limited Power Source (IEC60950 or UL1950), or be applied exemption.
- 13) Severe temperature condition may result in different luminance, response time and lamp ignition voltage.
- 14) Continuous operating TFT-LCD display under low temperature environment may accelerate lamp exhaustion and reduce luminance dramatically.
- 15) The data on this specification sheet is applicable when LCD module is placed in landscape position.
- 16) Continuous displaying fixed pattern may induce image sticking. It's recommended to use screen saver or shuffle content periodically if fixed pattern is displayed on the screen.



## 2. General Description

G173HW01 V0 is a Color Active Matrix Liquid Crystal Display composed of a TFT-LCD panel, a LED driver circuit, and a LED backlight system. The screen format is intended to support the FHD (1920(H) x 1080(V)) screen and 16.7M colors (RGB 6-bits + HiFRC data). All input signals are LVDS interface compatible. Inverter card of backlight is not included.

### 2.1 Display Characteristics

The following items are characteristics summary on the table under 25 °C condition:

Items	Unit	Specifications
Screen Diagonal	[mm]	439.42 (17.3")
Active Area	[mm]	381.888 (H) x 214.812 (V)
Pixels H x V		1920(x3) x 1080
Pixel Pitch	[mm]	0.1989 (per one triad) x 0.1989
Pixel Arrangement		R.G.B. Vertical Stripe
Display Mode		Normally White
White Luminance	[cd/m <sup>2</sup> ]	400 (Typ.)
Contrast Ratio		600 : 1 (Typ)
Optical ResponseTime	[msec]	40 (Typ, on/off)
Nominal Input Voltage VDD	[Volt]	3.3 V
Power Consumption	[Watt]	15 (Typ)
Weight	[Grams]	1080 (Typ)
Physical Size (H x V x D)	[mm]	403 (H) x 240 (V) x 12.5 (D) (Typ)
Electrical Interface		Dual channel LVDS
Surface Treatment		Hard-coating (3H), Glare treatment
Support Color		16.7M colors (RGB 6-bit data + HiFRC data)
Temperature Range (Ta) Operating Storage (Non-Operating)	[°C] [°C]	0 to +70 -20 to +70
RoHS Compliance		RoHS Compliance



### 2.2 Optical Characteristics

The optical characteristics are measured under stable conditions at 25°C (Room Temperature):

Item	Unit	Conditions	Min.	Typ.	Max.	Note
Viewing Angle	[degree]	Horizontal (Right) CR = 10 (Left)	70 70	80 80	-	1
		Vertical (Up) CR = 10 (Down)	60 45	80 60	-	
Luminance Uniformity	[%]	13 Points	75	80	-	2, 3
Optical Response Time	[msec]	Rising	-	37	50	4, 5
		Falling	-	3	10	
		Rising + Falling	-	40	60	
Color / Chromaticity Coordinates (CIE 1931)		Red x	0.590	0.640	0.690	4
		Red y	0.296	0.346	0.396	
		Green x	0.265	0.315	0.365	
		Green y	0.571	0.621	0.671	
		Blue x	0.098	0.148	0.198	
		Blue y	0.004	0.054	0.104	
		White x	0.254	0.304	0.354	
White y	0.263	0.313	0.363			
White Luminance (At LED=80mA)	[cd/m2 ]		320	400	-	4
Contrast Ratio			500	600	-	4
NTSC	%			72		

Optical Equipment: BM-5A, BM-7, PR880, or equivalent

**Note 1: Definition of viewing angle**

Viewing angle is the measurement of contrast ratio  $\geq 10$ , or  $\geq 5$ , at the screen center, over a  $180^\circ$  horizontal and  $180^\circ$  vertical range (off-normal viewing angles). The  $180^\circ$  viewing angle range is broken down as follows;  $90^\circ$  ( $\theta$ ) horizontal left and right and  $90^\circ$  ( $\Phi$ ) vertical, high (up) and low (down). The measurement direction is typically perpendicular to the display surface with the screen rotated about its center to develop the desired measurement viewing angle.

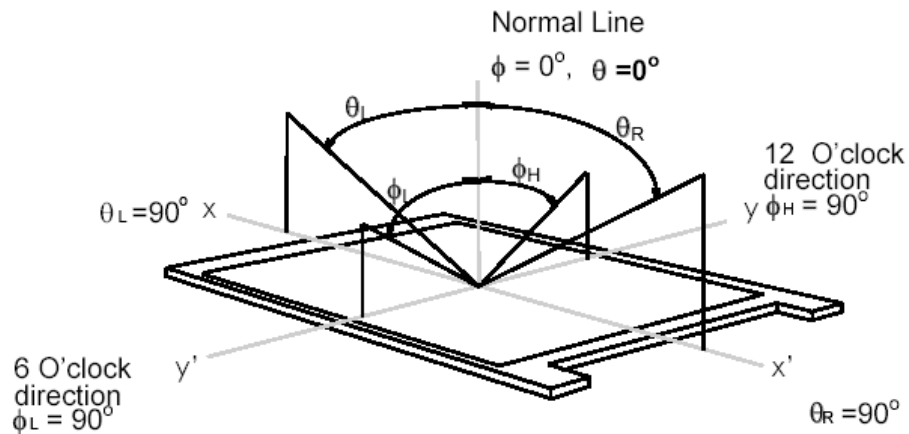
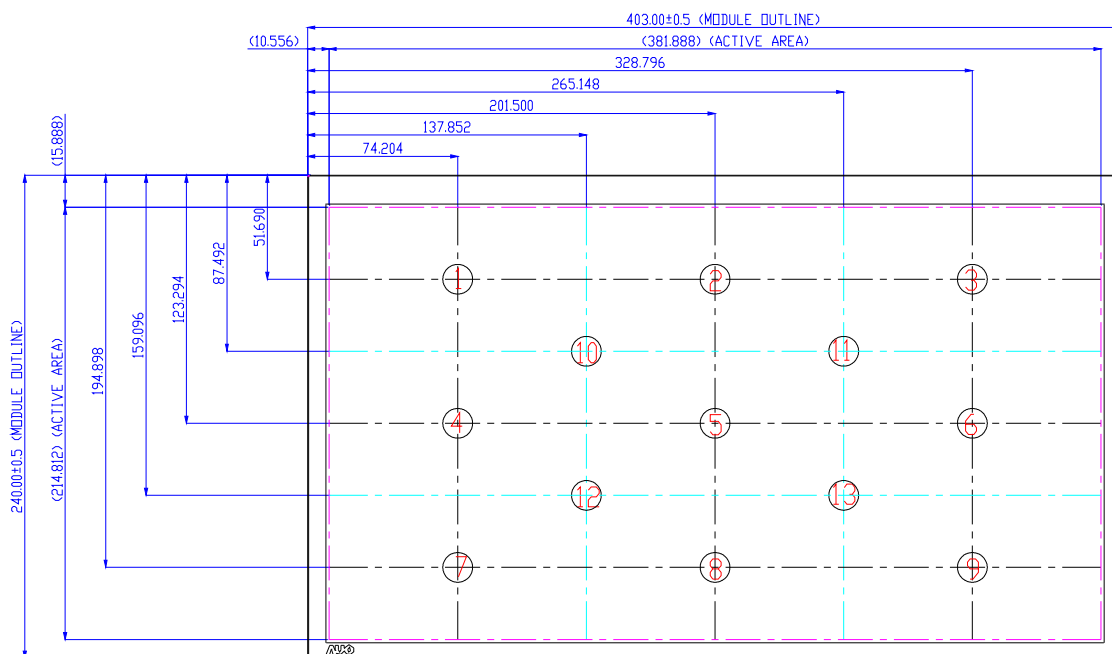

**Note 2: 13 points position**

Note 3:

$$\delta_{w13} = \frac{\text{Minimum Luminance of 13 points}}{\text{Maximum Luminance of 13 points}}$$

Note 4: Measurement method

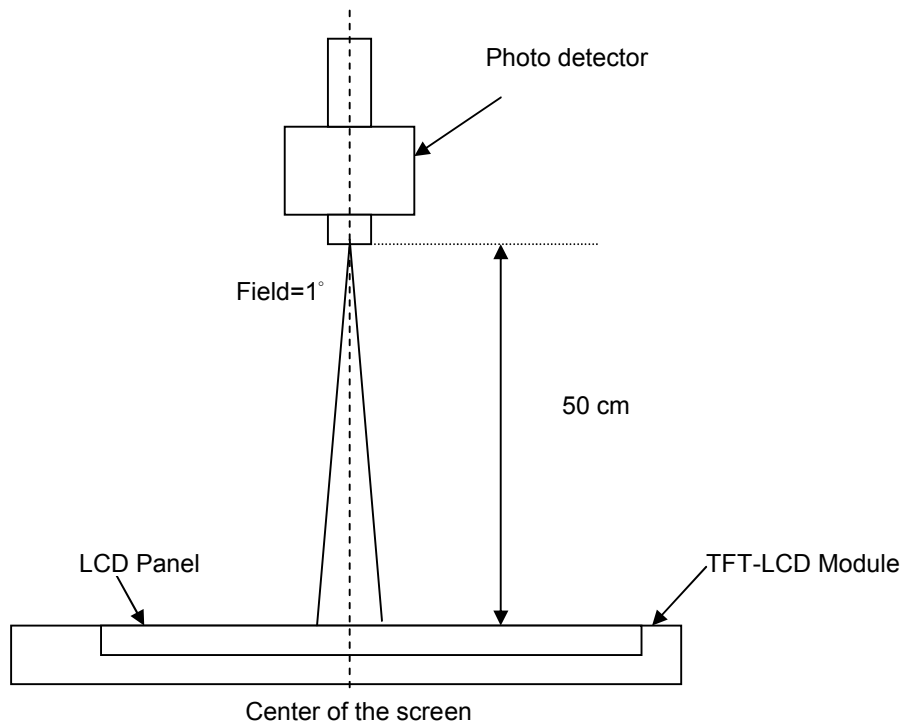
The LCD module should be stabilized at given temperature for 30 minutes to avoid abrupt temperature change during measuring. In order to stabilize the luminance, the measurement should be executed after lighting Backlight for 30 minutes in a stable, windless and dark room.





Note 5: Definition of response time:

The output signals of photo detector are measured when the input signals are changed from “Full Black” to “Full White” (rising time), and from “Full White” to “Full Black” (falling time), respectively. The response time is interval between the 10% and 90% of amplitudes. Please refer to the figure as below.

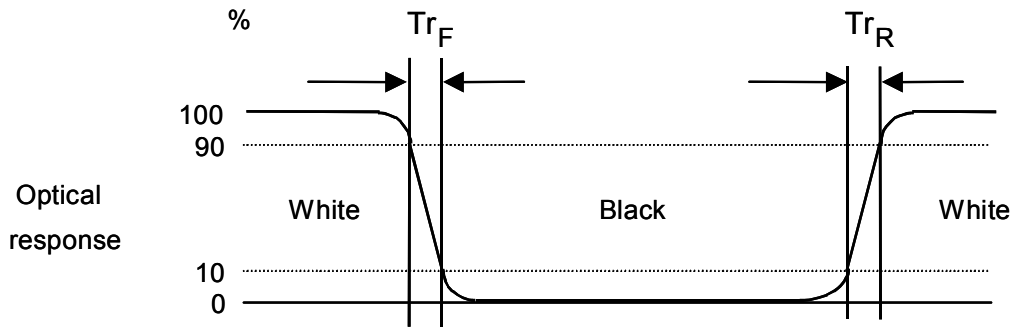

### 3. Functional Block Diagram

The following diagram shows the functional block of the 17.3 inches Color TFT-LCD Module:

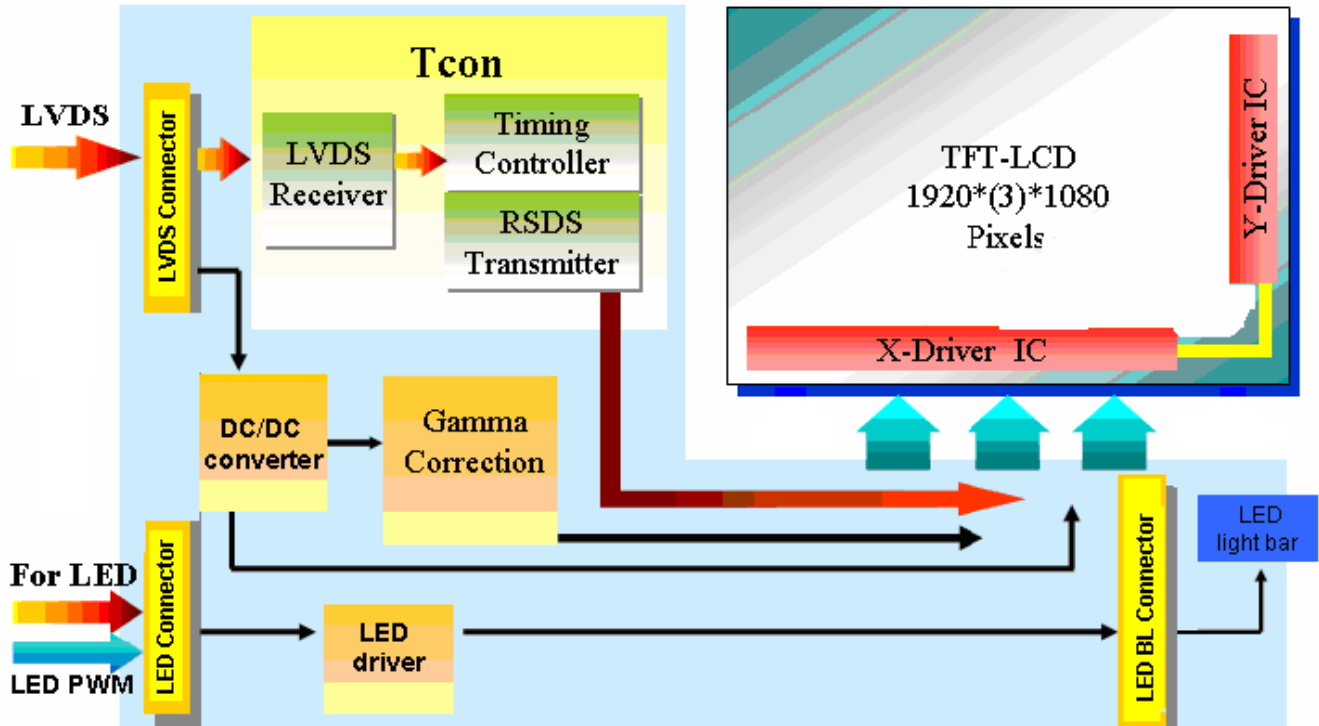

## 4. Absolute Maximum Ratings

Absolute maximum ratings of the module are as following:

### 4.1 Absolute Ratings of TFT LCD Module

Item	Symbol	Min	Max	Unit
Logic/LCD Drive Voltage	Vin	-0.3	+3.6	[Volt]

### 4.2 Absolute Ratings of Environment

Item	Symbol	Min	Max	Unit
Operating Temperature	TOP	0	+70	[°C]
Operation Humidity	HOP	5	95	[%RH]
Storage Temperature	TST	-20	+70	[°C]
Storage Humidity	HST	5	95	[%RH]

Note: Maximum Wet-Bulb should be 39°C and no condensation.

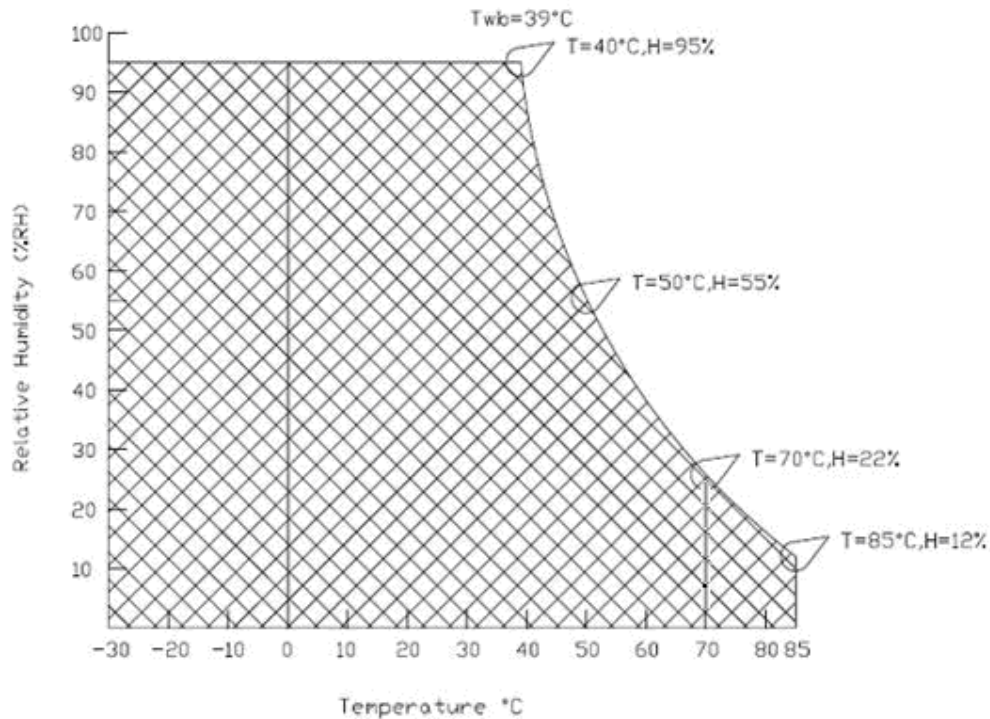

## 5. Electrical characteristics

### 5.1 TFT LCD Module

#### 5.1.1 Power Specification

Input power specifications are as follows:

Symble	Parameter	Min.	Typ.	Max.	Unit	Condition
VDD	Logic/LCD Drive Voltage	3.0	3.3	3.6	[Volt]	±10%
IDD	Input Current	-	1200	1400	[mA]	VDD= 3.3V, All Black Pattern At 60Hz, +30%
PDD	VDD Power	-	5	6	[Watt]	VDD= 3.3V, All Black Pattern At 60Hz , Note 1
IRush	Inrush Current	-	-	2000	[mA]	Note 2
VDDrp	Allowable Logic/LCD Drive Ripple Voltage	-	-	100	[mV] p-p	VDD= 3.3V, All Black Pattern At 75Hz

Note 1: The variance of VDD power consumption is ±30%.

Note 2: Measurement conditions:

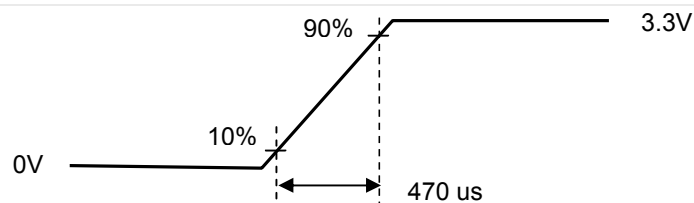
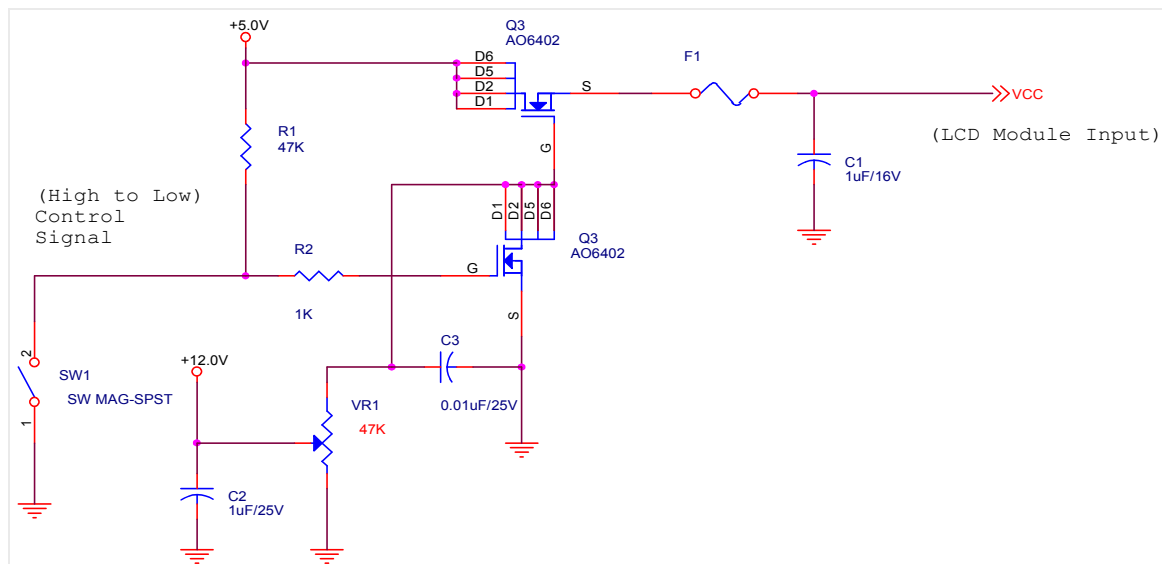

Vin rising time

Symbol	Item	Min.	Typ.	Max.	Unit	Remark
<b>VTH</b>	Differential Input High Threshold	-	-	100	[mV]	VCM=1.2V
<b>VTL</b>	Differential Input Low Threshold	-100	-	-	[mV]	VCM=1.2V
<b>  VID  </b>	Input Differential Voltage	100	400	600	[mV]	
<b>VICM</b>	Differential Input Common Mode Voltage	1.125	-	1.375	[V]	VTH/VTL=±100mV

## 5.1.2 Signal Electrical Characteristics

Input signals shall be low or Hi-Z state when VDD is off.

Note: LVDS Signal Waveform.

### Single-end Signal

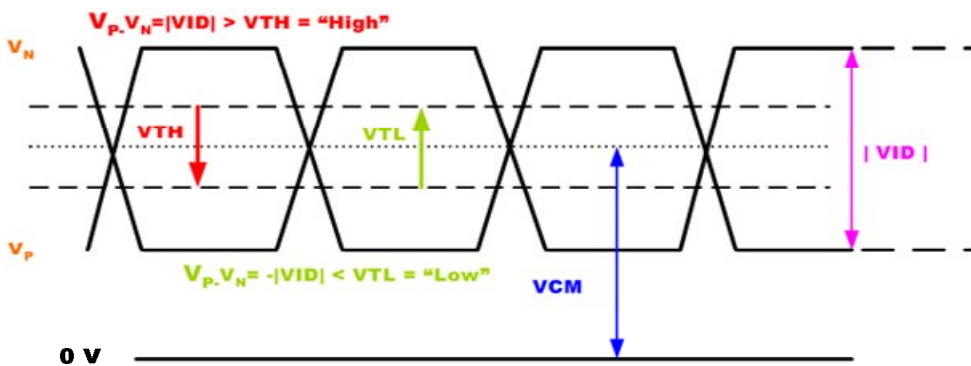

### Differential Signal

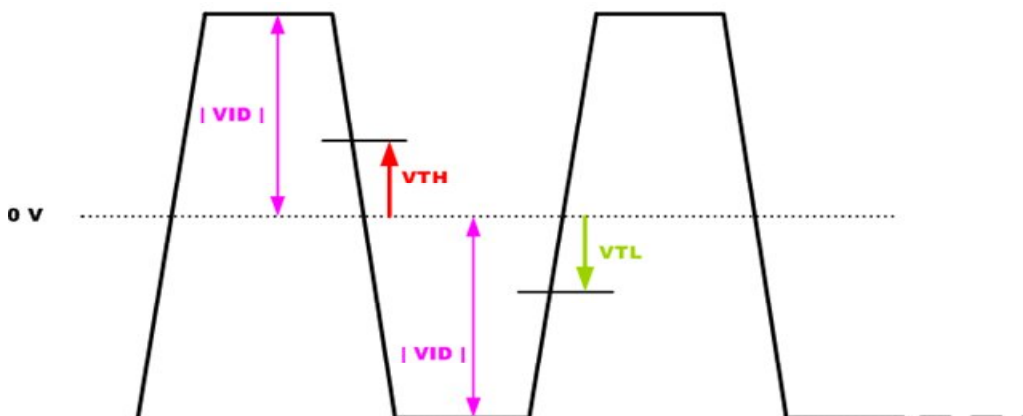

## 5.2 Backlight Unit

Following characteristics are measured under a stable condition using a inverter at 25°C. (Room Temperature):

Symbol	Parameter	Min.	Typ.	Max.	Unit	Remark
VCC	Input Voltage	10.8	12	13.2	[Volt]	
I <sub>VCC</sub>	Input Current	-	0.83	-	[A]	100% PWM Duty
P <sub>VCC</sub>	Power Consumption	-	9.96	12.9	[Watt]	100% PWM Duty
F <sub>PWM</sub>	Dimming Frequency	200	-	20K	[Hz]	
	Swing Voltage	3	3.3	5	[Volt]	
	Dimming duty cycle	5	-	100	%	
I <sub>F</sub>	LED Forward Current	-	80	-	[mA]	Ta = 25°C
V <sub>F</sub>	LED Forward Voltage	-	24.8	28.0	[Volt]	I <sub>F</sub> = 80mA, Ta = 0°C
		-	24.0	27.2	[Volt]	I <sub>F</sub> = 80mA, Ta = 25°C
		-	23.2	26.4	[Volt]	I <sub>F</sub> = 80mA, Ta = 70°C
P <sub>LED</sub>	LED Power Consumption	-	7.68	8.71	[Watt]	
LED Life Time		50,000	-	-	Hrs	I <sub>F</sub> =80mA, Ta= 25°C

Note 1: Ta means ambient temperature of TFT-LCD module.

Note 2: VCC, I<sub>VCC</sub>, P<sub>VCC</sub> are defined for LED backlight.(100% duty of PWM dimming)

Note 3: I<sub>F</sub>, V<sub>F</sub> are defined for one channel LED. There are four LED channel in back light unit.

Note 4: If G173HW01 V0 module is driven by high current or at high ambient temperature & humidity condition. The operating life will be reduced.

Note 5: Operating life means brightness goes down to 50% initial brightness. Minimum operating life time is estimated data.

Note 6: LED lifetime is definition: brightness is decreased to 50% of the initial value. LED lifetime is restricted under normal condition, ambient temperature = 25°C and LED operating I<sub>F</sub> = 80mA with AUO's original PCBA and LED driver board.

## 6. Signal Characteristic

### 6.1 Pixel Format Image

Following figure shows the relationship of the input signals and LCD pixel format.

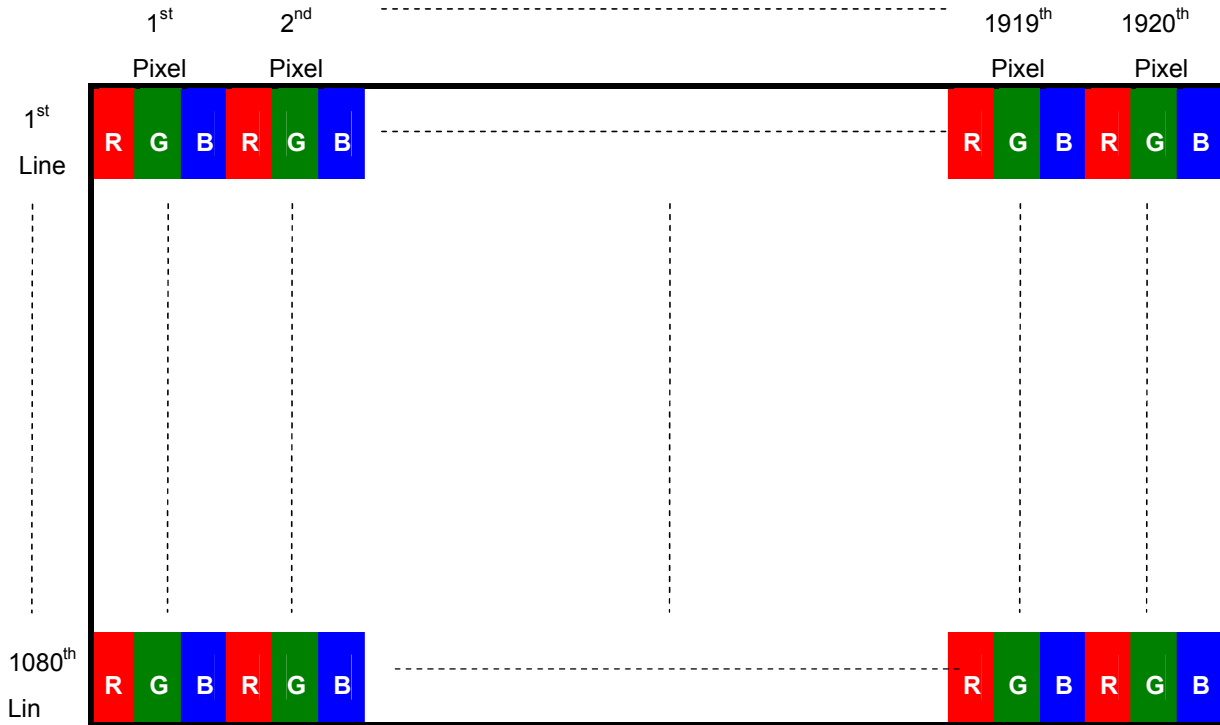

## 6.2 The Input Data Format

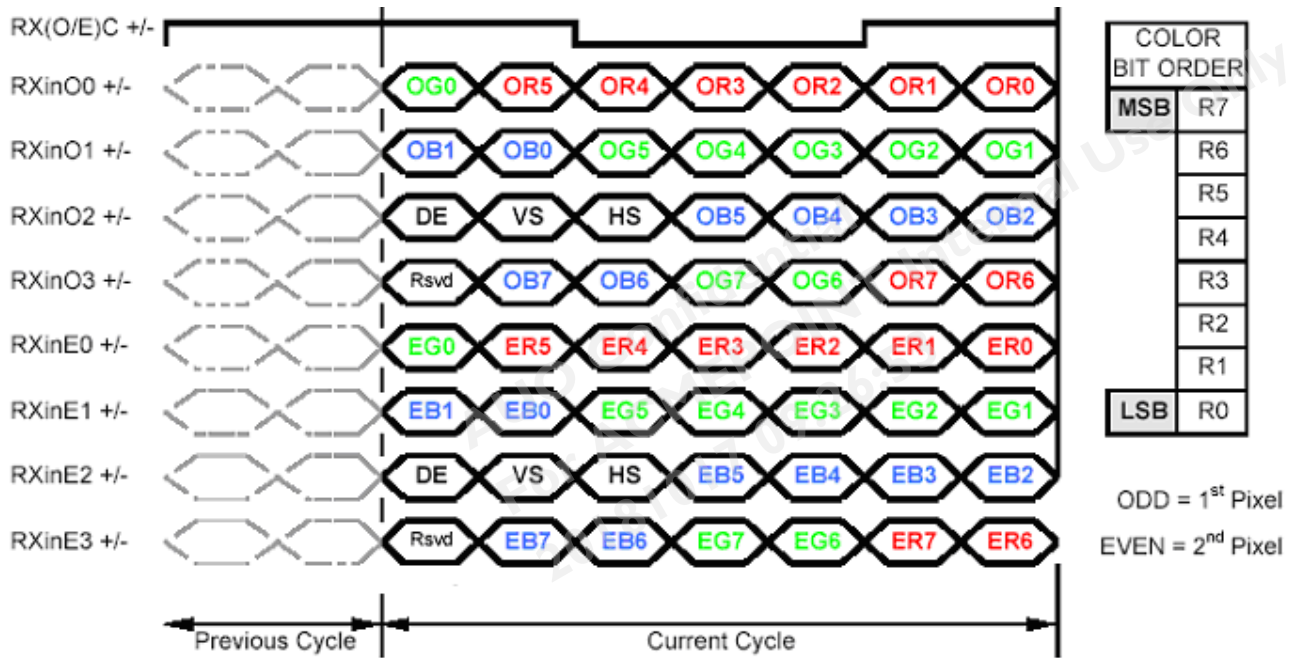

Note1: Normally, DE, VS, HS on EVEN channel are not used.

Note2: 8-bit in



## 6.3 Signal Description

The module using a pair of LVDS receiver SN75LVDS82(Texas Instruments) or compatible. LVDS is a differential signal technology for LCD interface and high speed data transfer device. Transmitter shall be SN75LVDS83(negative edge sampling) or compatible. The first LVDS port(RxOxxx) transmits odd pixels while the second LVDS port(RxExxx) transmits even pixels.

PIN #	SIGNAL NAME	DESCRIPTION
1	RxOIN0-	Negative LVDS differential data input (Odd data)
2	RxOIN0+	Positive LVDS differential data input (Odd data)
3	RxOIN1-	Negative LVDS differential data input (Odd data)
4	RxOIN1+	Positive LVDS differential data input (Odd data)
5	RxOIN2-	Negative LVDS differential data input (Odd data, H-Sync,V-Sync,DSPTMG)
6	RxOIN2+	Positive LVDS differential data input (Odd data, H-Sync,V-Sync,DSPTMG)
7	VSS	Power Ground
8	RxOCLKIN-	Negative LVDS differential clock input (Odd clock)
9	RxOCLKIN+	Positive LVDS differential clock input (Odd clock)
10	RxOIN3-	Negative LVDS differential data input (Odd data)
11	RxOIN3+	Positive LVDS differential data input (Odd data)
12	RxEIN0-	Negative LVDS differential data input (Even data)
13	RxEIN0+	Positive LVDS differential data input (Even data)
14	VSS	Power Ground
15	RxEIN1-	Negative LVDS differential data input (Even data)
16	RxEIN1+	Positive LVDS differential data input (Even data)
17	VSS	Power Ground
18	RxEIN2-	Negative LVDS differential data input (Even data)
19	RxEIN2+	Positive LVDS differential data input (Even data)
20	RxECLKIN-	Negative LVDS differential clock input (Even clock)
21	RxECLKIN+	Positive LVDS differential clock input (Even clock)
22	RxEIN3-	Negative LVDS differential data input (Even data)
23	RxEIN3+	Positive LVDS differential data input (Even data)
24	VSS	Power Ground
25	VSS	Power Ground
26	VSS	Power Ground
27	VSS	Power Ground
28	VDD	+3.3V Power Supply
29	VDD	+3.3V Power Supply
30	VDD	+3.3V Power Supply

Note1: Start from left side

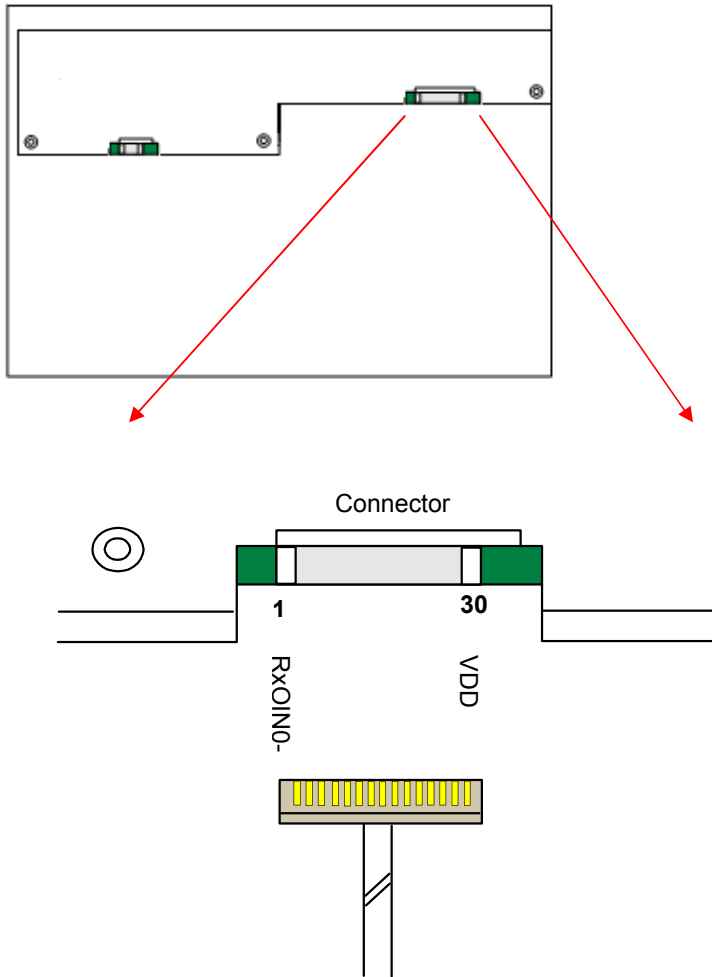

Note2: Input signals of odd and even clock shall be the same timing.

Note3: Please follow PSWG.

## 6.4 Interface Timing

### 6.4.1 Timing Characteristics

Basically, interface timings should match the 1920X1080 / 60Hz manufacturing guide line timing.

Parameter	Symbol	Min.	Typ.	Max.	Unit	
Frame Rate	-	50	60	65	Hz	
Clock frequency	$1/T_V$	57	72	118	MHZ	
Vertical Section	Period	$T_V$	1088	1130	1680	$T_{Line}$
	Active	$T_{VD}$	1080	1080	1080	
	Blanking	$T_{VB}$	8	50	600	
Horizontal Section	Period	$T_H$	1046	1050	1083	$T_{Clock}$
	Active	$T_{HD}$	960	960	960	
	Blanking	$T_{HB}$	86	90	123	

Note : DE mode only

### 6.4.2 Timing Diagram

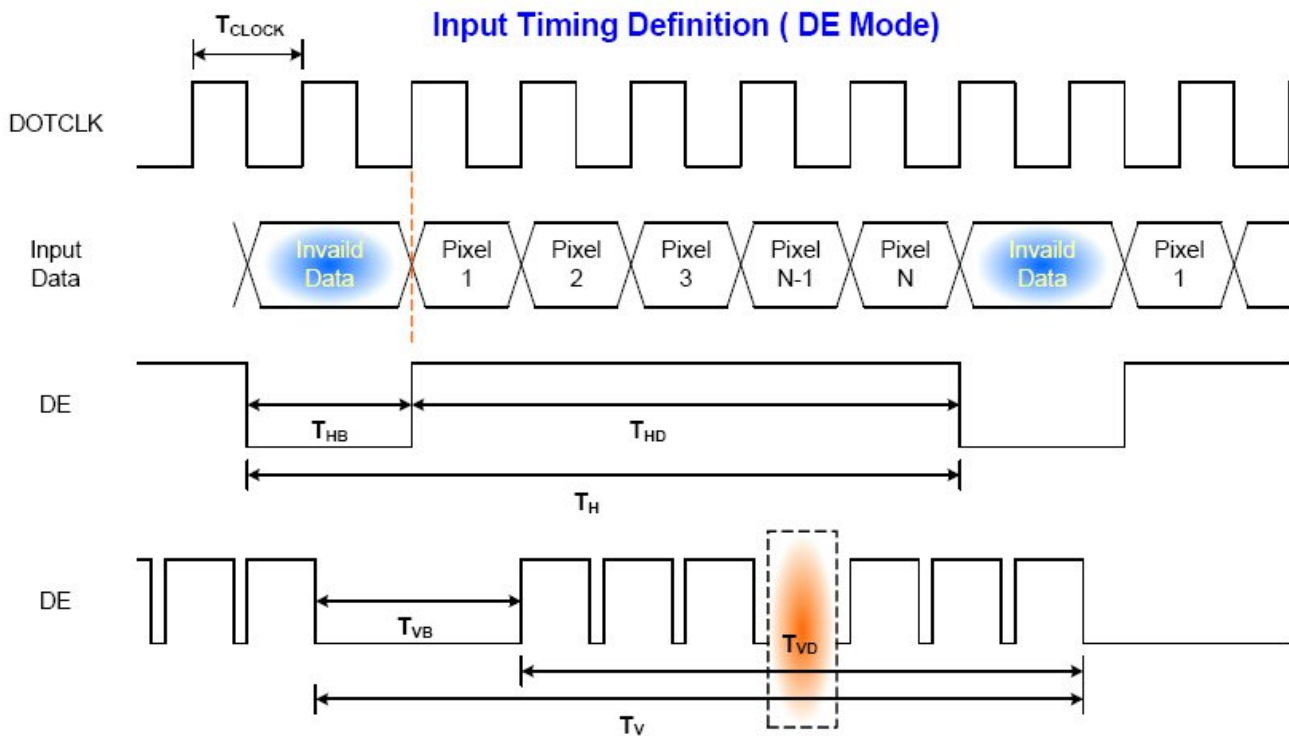

## 6.5 Power ON/OFF Sequence

VDD power and lamp on/off sequence is as follows. Interface signals are also shown in the chart. Signals from any system shall be Hi-Z state or low level when VDD is off.

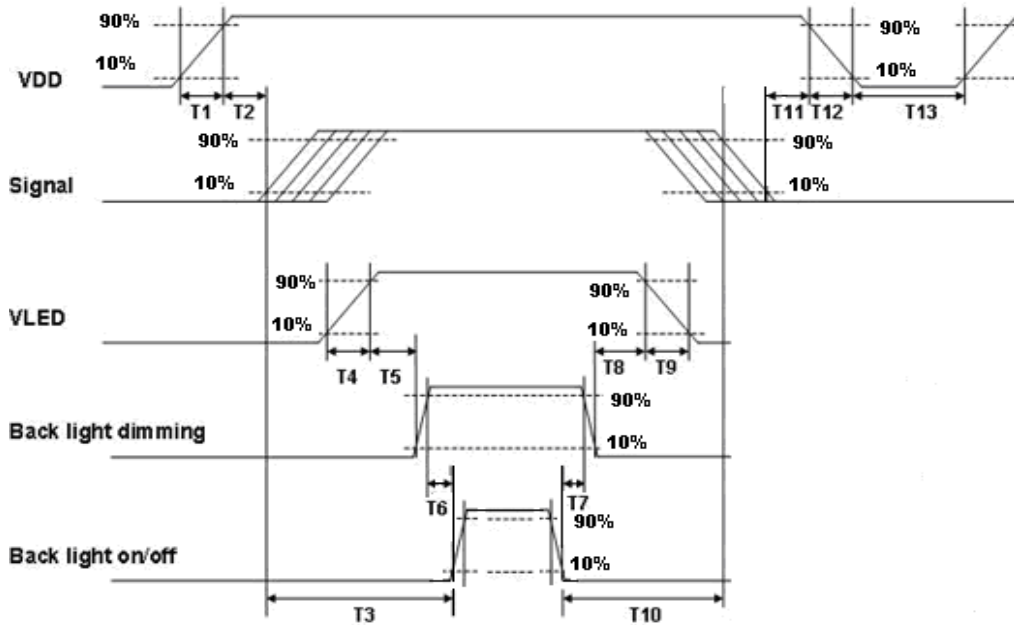

Power Sequence Timing

Power Sequence Timing				
Parameter	Value			Units
	Min.	Typ.	Max.	
T1	0.5	-	10	ms
T2	0	-	50	
T3	200	-	--	
T4	0.5	-	10	
T5	10	-	-	
T6	10	-	-	
T7	0	-	-	
T8	10	-	-	
T9	-	-	10	
T10	110	-	-	
T11	0	-	50	
T12	0	-	10	
T13	500	-	-	

## 7. Connector & Pin Assignment

Physical interface is described as for the connector on module. These connectors are capable of accommodating the following signals and will be following components.

### 7.1 TFT LCD Module

#### 7.1.1 Connector

Connector Name / Designation	Interface Connector / Interface card
Manufacturer	HRS
Type Part Number	MDF76TW-30S-1H
Mating Type Part Number	MDF76-30P-1C

#### 7.1.2 Pin Assignment

Pin#	Signal Name	Pin#	Signal Name
1	RxOIN0-	2	RxOIN0+
3	RxOIN1-	4	RxOIN1+
5	RxOIN2-	6	RxOIN2+
7	VSS	8	RxOCLKIN-
9	RxOCLKIN+	10	RxOIN3-
11	RxOIN3+	12	RxEIN0-
13	RxEIN0+	14	VSS
15	RxEIN1-	16	RxEIN1+
17	VSS	18	RxEIN2-
19	RxEIN2+	20	RxECLKIN-
21	RxECLKIN+	22	RxEIN3-
23	RxEIN3+	24	VSS
25	VSS	26	VSS
27	VSS	28	VDD
29	VDD	30	VDD

## 7.2 Backlight Unit

Physical interface is described as for the connector on module. These connectors are capable of accommodating the following signals and will be following components.

### 7.2.1 Connector

Connector Name / Designation	Lamp Connector / Backlight lamp
Manufacturer	HRS
Type Part Number	DF14A-6P-1.25H
Mating Type Part Number	DF14-6S-1.25C

### 7.2.2 Pin Assignment

Pin No.	Symbol	Description
Pin1	VLED	12V input
Pin2	VLED	12V input
Pin3	GND	GND
Pin4	GND	GND
Pin5	On/OFF	3.3-5V:ON, 0V:OFF
Pin6	Dimming	PWM

## 8. Reliability Test

Environment test conditions are listed as following table.

Items	Required Condition	Note
Temperature Humidity Bias (THB)	Ta= 50°C, 80%RH, 240hours	
High Temperature Operation (HTO)	Ta= 70°C, 240hours	
Low Temperature Operation (LTO)	Ta= 0°C, 240hours	
High Temperature Storage (HTS)	Ta= 70°C, 240hours	
Low Temperature Storage (LTS)	Ta= -20°C, 240hours	
Vibration Test (Non-operation)	Acceleration: 1.5 G Wave: Random Frequency: 10 - 200 - 10 Hz Sweep: 30 Minutes each Axis (X, Y, Z)	
Shock Test (Non-operation)	Acceleration: 50 G Wave: Half-sine Active Time: 20 ms Direction: ±X, ±Y, ±Z (one time for each Axis)	
Drop Test	Height: 60 cm, package test	
Thermal Shock Test (TST)	-20°C/30min, 60°C/30min, 50 cycles	1
ESD (Electro-Static Discharge)	Contact Discharge: ± 8KV, 150pF(330Ω ) 1sec, 8 points, 25 times/ point.	2
	Air Discharge: ± 15KV, 150pF(330Ω ) 1sec 8 points, 25 times/ point.	

Note 1: The TFT-LCD module will not sustain damage after being subjected to 100 cycles of rapid temperature change. A cycle of rapid temperature change consists of varying the temperature from -20°C to 60°C, and back again. Power is not applied during the test. After temperature cycling, the unit is placed in normal room ambient for at least 4 hours before power on.

Note 2: According to EN61000-4-2, ESD class B: Some performance degradation allowed. No data lost. Self-recoverable. No hardware failures.

## 9. Label

### 9.1. Shipping Label

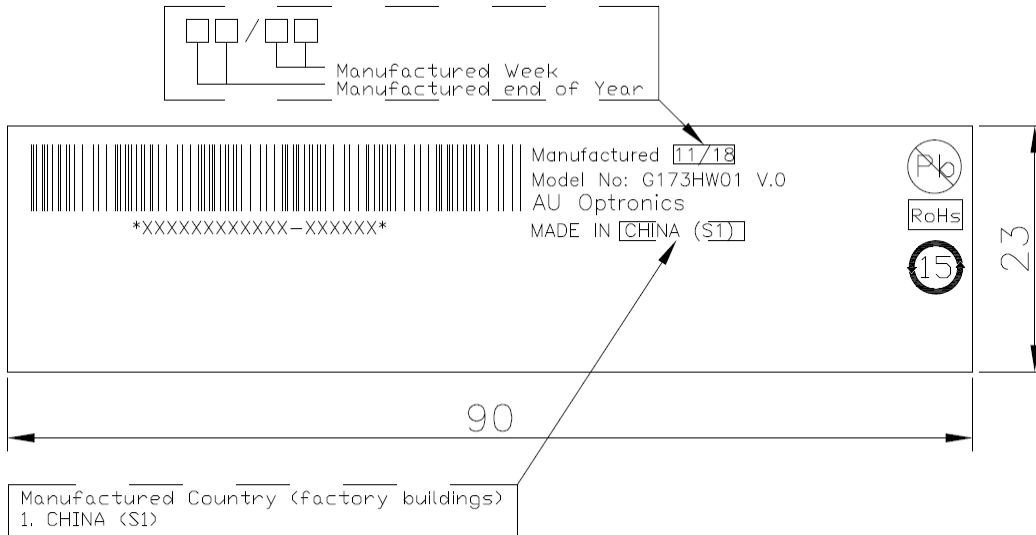

Unit: mm

A. Manufactured end of year mark						B. Manufactured week mark			
Mark	08	09	10	11	...	Mark	01	02	...
Definition	2008	2009	2010	2011	...	Definition	1st Week	2nd Week	...

Shipping No. has 18 digits: for example: VW7400100001-PM0100  
**VW74001**00001-PM0100 => Lot number  
 VW74001**00001**-PM0100 => Serial number  
 VW7400100001-**PM0100** => Factory number

### 9.2. BLU Label

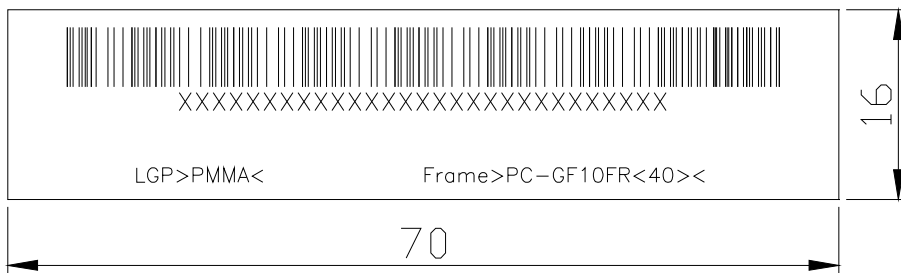

Unit: mm



## 10. Packing Form

### 10.1 Packaging material

FILM PROTECT
BAG ANTI-STATIC
TAPE
TAPE CREPED PAPER
PACKING CARTON
LABEL SPEC
LABEL CARTON.
CUSHION PACKING

### 10.2 External packaging material required

- Carton : 524mm\*321mm\*360mm, weight (carton + cushion): 1250g

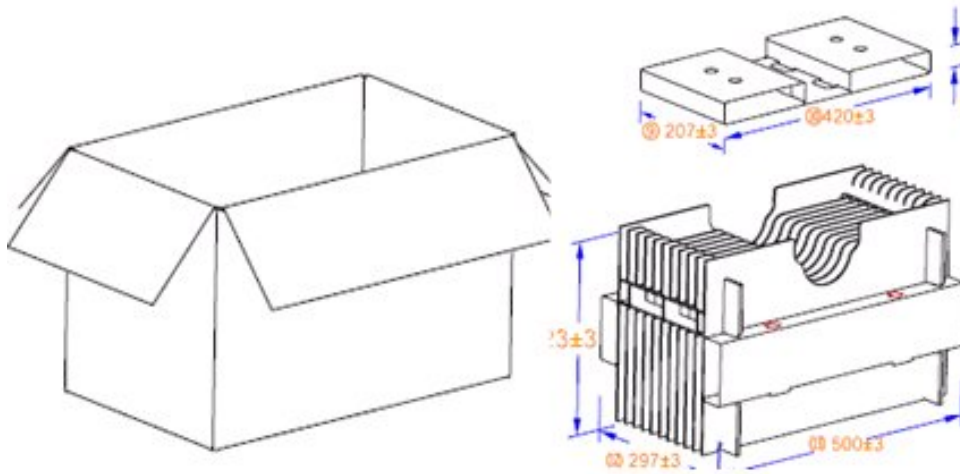

- Pallet : 1140mm\*980mm\*140mm
- Stretch film : 500mm (W)\*300M (L)
- Corner angle : L type fiber board
- PET band : 19mm (W)
- Label : 220mm\*200mm

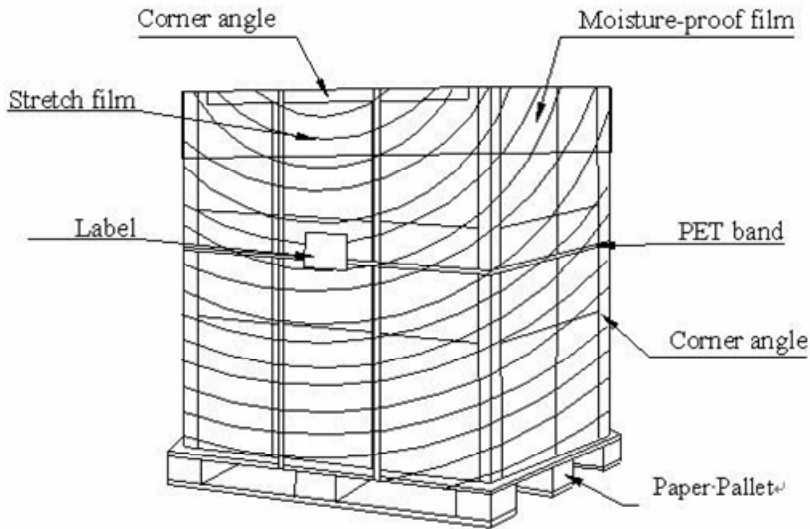

### 10.3 Palletizing sequence

	pcs / box	box / layer	layer / pallet	pcs / pallet
Shipping by air	10	2*3	3	180
Shipping by sea	10	2*3	3+3 (max)	360 (max)

10.4 Packing instruction

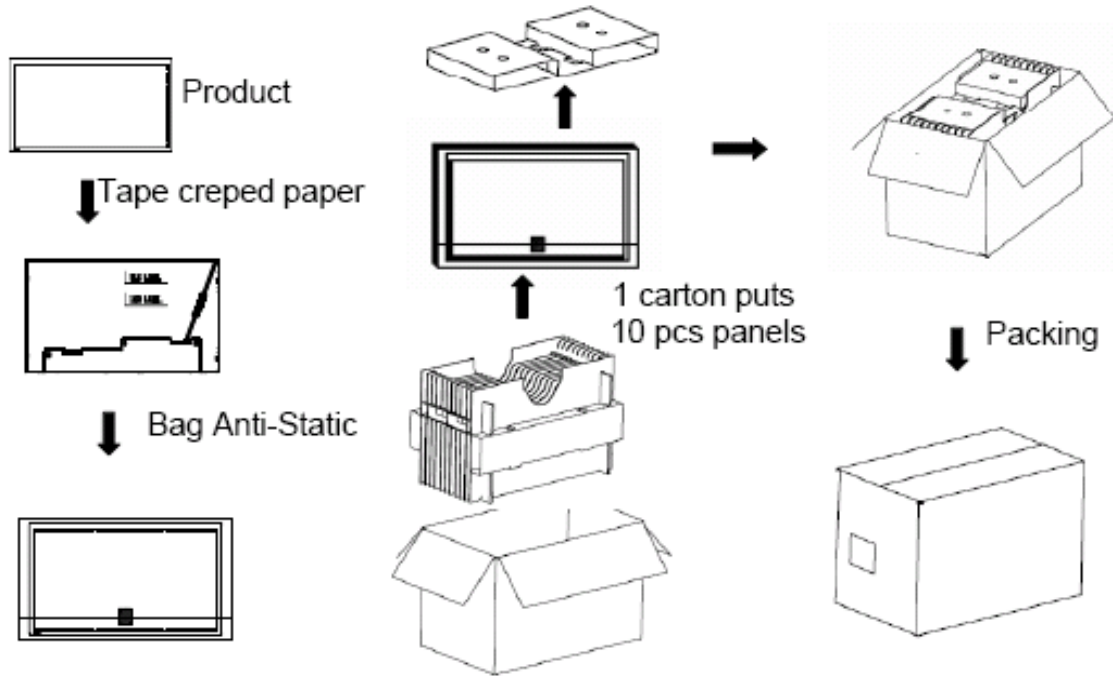



# 11. Outline Drawing

## Product Specification

G173HW01 V0

AU OPTRONICS CORPORATION

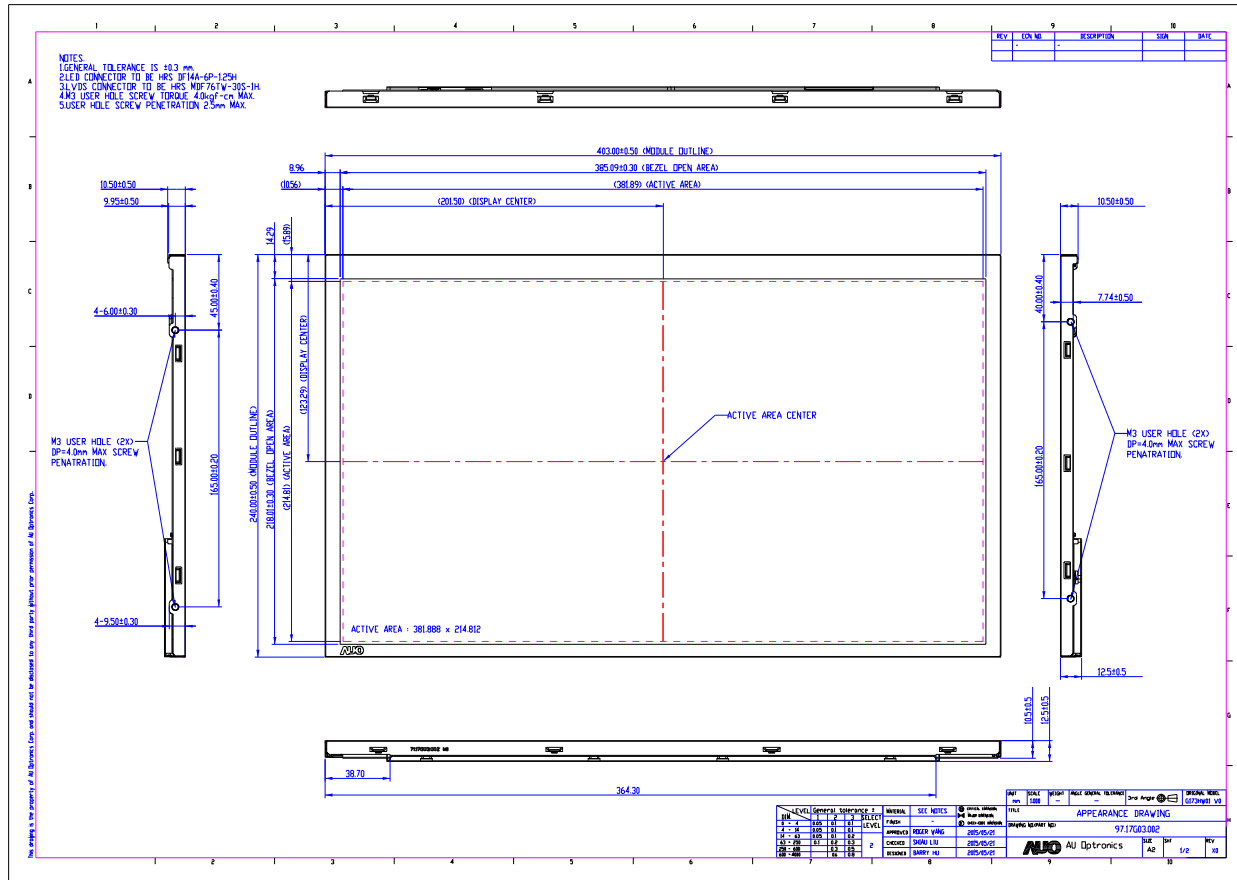



# Product Specification

G173HW01 V0

AU OPTRONICS CORPORATION

