



( ) Preliminary Specification  
(V) Final Specification

<b>Module</b>	18.5" Color TFT-LCD
<b>Model Name</b>	G185XW01 V201

Customer	Date
_____	_____
<b>Approved by</b>	
_____	_____
<p>Note: This Specification is subject to change without notice.</p>	

Approved by	Date
<u>Crystal Hsieh</u>	<u>2018/11/26</u>
<b>Prepared by</b>	
<u>Athena Wu</u>	<u>2018/11/26</u>
<p>General Display Business Unit / AU Optronics corporation</p>	

## Contents

<b>1.0 Handling Precautions</b> .....	<b>4</b>
<b>2.0 General Description</b> .....	<b>5</b>
2.1 Display Characteristics.....	5
2.2 Optical Characteristics .....	6
<b>3.0 Functional Block Diagram</b> .....	<b>10</b>
<b>4.0 Absolute Maximum Ratings</b> .....	<b>11</b>
4.1 TFT LCD Module.....	11
4.2 Absolute Ratings of Environment.....	11
<b>5.0 Electrical characteristics</b> .....	<b>12</b>
5.1 TFT LCD Module.....	12
5.1.1 Power Specification .....	12
5.1.2 Signal Electrical Characteristics.....	13
5.2 Backlight Unit.....	14
<b>6.0 Signal Characteristic</b> .....	<b>15</b>
6.1 Pixel Format Image .....	15
6.2 The input data format.....	15
6.3 Signal Description .....	16
6.4 Timing Characteristics.....	18
6.5 Timing diagram .....	19
6.6 Power ON/OFF Sequence .....	20
<b>7.0 Connector &amp; Pin Assignment</b> .....	<b>21</b>
7.1 TFT LCD Module.....	21
7.2 LED Backlight Unit: LED Driver Connector .....	21
7.3 LED Driver Connector Pin Assignment .....	22
<b>8.0 Reliability Test</b> .....	<b>23</b>
<b>9.0 Shipping Label &amp; Packaging</b> .....	<b>24</b>
9.1 Shipping Label .....	24
9.2 Packaging .....	25
9.3 Palletizing.....	26
<b>10.0 Mechanical Characteristics</b> .....	<b>27</b>
<b>11 Safety</b> .....	<b>29</b>
11.1 Sharp Edge Requirements.....	29
11.2 Materials.....	29
11.3 Capacitors .....	29
11.4 National Test Lab Requirement.....	29

## Record of Revision

Version & Date	Page	Old description	New Description																																																																																																																																																																																																																								
0.0 2017/10/11	All		Preliminary spec																																																																																																																																																																																																																								
0.1 2018/11/26	5	Power Consumption (VDD line + LED line) 13.5W(Typ.) (Pdd=4.5W , PLED=9W)	Power Consumption (VDD line + LED line) 8.25W(Typ.) (Pdd=2.25W , PLED=6W)																																																																																																																																																																																																																								
	12	5.1.1 Power Specification  <table border="1" style="font-size: 8px; width: 100%;"> <thead> <tr> <th>Symbol</th> <th>Parameter</th> <th>Min.</th> <th>Typ.</th> <th>Max.</th> <th>Unit</th> <th>Conditions</th> </tr> </thead> <tbody> <tr> <td>VDD</td> <td>Logic/LCD Drive Voltage</td> <td>4.5</td> <td>5.0</td> <td>5.5</td> <td>[Volt]</td> <td>+/-10%</td> </tr> <tr> <td>IDD</td> <td>Input Current</td> <td>-</td> <td>0.9</td> <td>1.1</td> <td>[A]</td> <td>VDD= 5.0V, All Black Pattern At 60Hz,</td> </tr> <tr> <td>PDD</td> <td>VDD Power</td> <td>-</td> <td>4.5</td> <td>5.5</td> <td>[Watt]</td> <td>VDD= 5.0V, All Black Pattern At 60Hz</td> </tr> <tr> <td>IRush</td> <td>Inrush Current</td> <td>-</td> <td>-</td> <td>3</td> <td>[A]</td> <td>Note 1</td> </tr> <tr> <td>VDDrp</td> <td>Allowable Logic/LCD Drive Ripple Voltage</td> <td>-</td> <td>-</td> <td>200</td> <td>[mV] p-p</td> <td>VDD= 5.0V, All Black Pattern At 60Hz</td> </tr> </tbody> </table>	Symbol	Parameter	Min.	Typ.	Max.	Unit	Conditions	VDD	Logic/LCD Drive Voltage	4.5	5.0	5.5	[Volt]	+/-10%	IDD	Input Current	-	0.9	1.1	[A]	VDD= 5.0V, All Black Pattern At 60Hz,	PDD	VDD Power	-	4.5	5.5	[Watt]	VDD= 5.0V, All Black Pattern At 60Hz	IRush	Inrush Current	-	-	3	[A]	Note 1	VDDrp	Allowable Logic/LCD Drive Ripple Voltage	-	-	200	[mV] p-p	VDD= 5.0V, All Black Pattern At 60Hz	5.1.1 Power Specification  <table border="1" style="font-size: 8px; width: 100%;"> <thead> <tr> <th>Symbol</th> <th>Parameter</th> <th>Min.</th> <th>Typ.</th> <th>Max.</th> <th>Unit</th> <th>Conditions</th> </tr> </thead> <tbody> <tr> <td>VDD</td> <td>Logic/LCD Drive Voltage</td> <td>4.5</td> <td>5.0</td> <td>5.5</td> <td>[Volt]</td> <td>+/-10%</td> </tr> <tr> <td>IDD</td> <td>Input Current</td> <td>-</td> <td>0.45</td> <td>0.55</td> <td>[A]</td> <td>VDD= 5.0V, All Black Pattern At 60Hz,</td> </tr> <tr> <td>PDD</td> <td>VDD Power</td> <td>-</td> <td>2.25</td> <td>3</td> <td>[Watt]</td> <td>VDD= 5.0V, All Black Pattern At 60Hz</td> </tr> <tr> <td>IRush</td> <td>Inrush Current</td> <td>-</td> <td>-</td> <td>3</td> <td>[A]</td> <td>Note 1</td> </tr> <tr> <td>VDDrp</td> <td>Allowable Logic/LCD Drive Ripple Voltage</td> <td>-</td> <td>-</td> <td>200</td> <td>[mV] p-p</td> <td>VDD= 5.0V, All Black Pattern At 60Hz</td> </tr> </tbody> </table>	Symbol	Parameter	Min.	Typ.	Max.	Unit	Conditions	VDD	Logic/LCD Drive Voltage	4.5	5.0	5.5	[Volt]	+/-10%	IDD	Input Current	-	0.45	0.55	[A]	VDD= 5.0V, All Black Pattern At 60Hz,	PDD	VDD Power	-	2.25	3	[Watt]	VDD= 5.0V, All Black Pattern At 60Hz	IRush	Inrush Current	-	-	3	[A]	Note 1	VDDrp	Allowable Logic/LCD Drive Ripple Voltage	-	-	200	[mV] p-p	VDD= 5.0V, All Black Pattern At 60Hz																																																																																																																																				
Symbol	Parameter	Min.	Typ.	Max.	Unit	Conditions																																																																																																																																																																																																																					
VDD	Logic/LCD Drive Voltage	4.5	5.0	5.5	[Volt]	+/-10%																																																																																																																																																																																																																					
IDD	Input Current	-	0.9	1.1	[A]	VDD= 5.0V, All Black Pattern At 60Hz,																																																																																																																																																																																																																					
PDD	VDD Power	-	4.5	5.5	[Watt]	VDD= 5.0V, All Black Pattern At 60Hz																																																																																																																																																																																																																					
IRush	Inrush Current	-	-	3	[A]	Note 1																																																																																																																																																																																																																					
VDDrp	Allowable Logic/LCD Drive Ripple Voltage	-	-	200	[mV] p-p	VDD= 5.0V, All Black Pattern At 60Hz																																																																																																																																																																																																																					
Symbol	Parameter	Min.	Typ.	Max.	Unit	Conditions																																																																																																																																																																																																																					
VDD	Logic/LCD Drive Voltage	4.5	5.0	5.5	[Volt]	+/-10%																																																																																																																																																																																																																					
IDD	Input Current	-	0.45	0.55	[A]	VDD= 5.0V, All Black Pattern At 60Hz,																																																																																																																																																																																																																					
PDD	VDD Power	-	2.25	3	[Watt]	VDD= 5.0V, All Black Pattern At 60Hz																																																																																																																																																																																																																					
IRush	Inrush Current	-	-	3	[A]	Note 1																																																																																																																																																																																																																					
VDDrp	Allowable Logic/LCD Drive Ripple Voltage	-	-	200	[mV] p-p	VDD= 5.0V, All Black Pattern At 60Hz																																																																																																																																																																																																																					
	14	5.2 Backlight Unit  <table border="1" style="font-size: 8px; width: 100%;"> <thead> <tr> <th>Symbol</th> <th>Parameter</th> <th>Min.</th> <th>Typ.</th> <th>Max.</th> <th>Unit</th> <th>Remark</th> </tr> </thead> <tbody> <tr> <td>VCC</td> <td>Input Voltage</td> <td>10.8</td> <td>12</td> <td>13.2</td> <td>[Volt]</td> <td></td> </tr> <tr> <td>I<sub>VCC</sub></td> <td>Input Current</td> <td></td> <td>0.75</td> <td>1</td> <td>[A]</td> <td>100% PWM Duty</td> </tr> <tr> <td>P<sub>VCC</sub></td> <td>Power Consumption</td> <td></td> <td>9</td> <td>13.2</td> <td>[Watt]</td> <td>100% PWM Duty</td> </tr> <tr> <td>I<sub>rush LED</sub></td> <td>Inrush Current</td> <td>-</td> <td>-</td> <td>3</td> <td>[A]</td> <td>at rising time=470us</td> </tr> <tr> <td rowspan="2">V<sub>LED on/off</sub></td> <td>On Control Voltage</td> <td>3</td> <td>5</td> <td>5.5</td> <td>Volt</td> <td></td> </tr> <tr> <td>Off Control Voltage</td> <td></td> <td></td> <td>0.8</td> <td>Volt</td> <td></td> </tr> <tr> <td rowspan="4">F<sub>FWM</sub></td> <td>Dimming Frequency</td> <td>200</td> <td>-</td> <td>20k</td> <td>[Hz]</td> <td></td> </tr> <tr> <td>Swing Voltage</td> <td>3</td> <td>3.3</td> <td>5</td> <td>V</td> <td></td> </tr> <tr> <td>High Voltage</td> <td>3</td> <td>3.3</td> <td>5.5</td> <td>Volt</td> <td></td> </tr> <tr> <td>Low Voltage</td> <td></td> <td></td> <td>0.8</td> <td>Volt</td> <td></td> </tr> <tr> <td></td> <td>Dimming Duty Cycle</td> <td>5</td> <td>-</td> <td>100</td> <td>%</td> <td></td> </tr> <tr> <td>I<sub>f</sub></td> <td>LED Forward Current</td> <td></td> <td>45</td> <td></td> <td>mA</td> <td>Ta = 25°C</td> </tr> <tr> <td>V<sub>f</sub></td> <td>LED Forward Voltage</td> <td>-</td> <td>3.2</td> <td>3.6</td> <td>Volt</td> <td>I<sub>f</sub> 50=mA, Ta = 25°C</td> </tr> <tr> <td>P<sub>LED</sub></td> <td>LED Power Consumption</td> <td>-</td> <td></td> <td>6.804</td> <td>Watt</td> <td>I<sub>f</sub> 50=mA, Ta = 25°C</td> </tr> <tr> <td>Operation Lifetime</td> <td></td> <td>50,000</td> <td></td> <td></td> <td>Hrs</td> <td>I<sub>f</sub> 50=mA, Ta = 25°C</td> </tr> </tbody> </table>	Symbol	Parameter	Min.	Typ.	Max.	Unit	Remark	VCC	Input Voltage	10.8	12	13.2	[Volt]		I <sub>VCC</sub>	Input Current		0.75	1	[A]	100% PWM Duty	P <sub>VCC</sub>	Power Consumption		9	13.2	[Watt]	100% PWM Duty	I <sub>rush LED</sub>	Inrush Current	-	-	3	[A]	at rising time=470us	V <sub>LED on/off</sub>	On Control Voltage	3	5	5.5	Volt		Off Control Voltage			0.8	Volt		F <sub>FWM</sub>	Dimming Frequency	200	-	20k	[Hz]		Swing Voltage	3	3.3	5	V		High Voltage	3	3.3	5.5	Volt		Low Voltage			0.8	Volt			Dimming Duty Cycle	5	-	100	%		I <sub>f</sub>	LED Forward Current		45		mA	Ta = 25°C	V <sub>f</sub>	LED Forward Voltage	-	3.2	3.6	Volt	I <sub>f</sub> 50=mA, Ta = 25°C	P <sub>LED</sub>	LED Power Consumption	-		6.804	Watt	I <sub>f</sub> 50=mA, Ta = 25°C	Operation Lifetime		50,000			Hrs	I <sub>f</sub> 50=mA, Ta = 25°C	5.2 Backlight Unit  <table border="1" style="font-size: 8px; width: 100%;"> <thead> <tr> <th>Symbol</th> <th>Parameter</th> <th>Min.</th> <th>Typ.</th> <th>Max.</th> <th>Unit</th> <th>Remark</th> </tr> </thead> <tbody> <tr> <td>VCC</td> <td>Input Voltage</td> <td>10.8</td> <td>12</td> <td>13.2</td> <td>[Volt]</td> <td></td> </tr> <tr> <td>I<sub>VCC</sub></td> <td>Input Current</td> <td></td> <td>0.5</td> <td>0.6</td> <td>[A]</td> <td>100% PWM Duty</td> </tr> <tr> <td>P<sub>VCC</sub></td> <td>Power Consumption</td> <td></td> <td>6</td> <td>7.92</td> <td>[Watt]</td> <td>100% PWM Duty</td> </tr> <tr> <td>I<sub>rush LED</sub></td> <td>Inrush Current</td> <td>-</td> <td>-</td> <td>3</td> <td>[A]</td> <td>at rising time=470us</td> </tr> <tr> <td rowspan="2">V<sub>LED on/off</sub></td> <td>On Control Voltage</td> <td>3</td> <td>5</td> <td>5.5</td> <td>Volt</td> <td></td> </tr> <tr> <td>Off Control Voltage</td> <td></td> <td></td> <td>0.8</td> <td>Volt</td> <td></td> </tr> <tr> <td rowspan="4">F<sub>FWM</sub></td> <td>Dimming Frequency</td> <td>200</td> <td>-</td> <td>20k</td> <td>[Hz]</td> <td></td> </tr> <tr> <td>Swing Voltage</td> <td>3</td> <td>3.3</td> <td>5</td> <td>V</td> <td></td> </tr> <tr> <td>High Voltage</td> <td>3</td> <td>3.3</td> <td>5.5</td> <td>Volt</td> <td></td> </tr> <tr> <td>Low Voltage</td> <td></td> <td></td> <td>0.8</td> <td>Volt</td> <td></td> </tr> <tr> <td></td> <td>Dimming Duty Cycle</td> <td>5</td> <td>-</td> <td>100</td> <td>%</td> <td></td> </tr> <tr> <td>I<sub>f</sub></td> <td>LED Forward Current</td> <td></td> <td>45</td> <td></td> <td>mA</td> <td>Ta = 25°C</td> </tr> <tr> <td>V<sub>f</sub></td> <td>LED Forward Voltage</td> <td>-</td> <td>3.2</td> <td>3.6</td> <td>Volt</td> <td>I<sub>f</sub> 50=mA, Ta = 25°C</td> </tr> <tr> <td>P<sub>LED</sub></td> <td>LED Power Consumption</td> <td>-</td> <td></td> <td>6.804</td> <td>Watt</td> <td>I<sub>f</sub> 50=mA, Ta = 25°C</td> </tr> <tr> <td>Operation Lifetime</td> <td></td> <td>50,000</td> <td></td> <td></td> <td>Hrs</td> <td>I<sub>f</sub> 50=mA, Ta = 25°C</td> </tr> </tbody> </table>	Symbol	Parameter	Min.	Typ.	Max.	Unit	Remark	VCC	Input Voltage	10.8	12	13.2	[Volt]		I <sub>VCC</sub>	Input Current		0.5	0.6	[A]	100% PWM Duty	P <sub>VCC</sub>	Power Consumption		6	7.92	[Watt]	100% PWM Duty	I <sub>rush LED</sub>	Inrush Current	-	-	3	[A]	at rising time=470us	V <sub>LED on/off</sub>	On Control Voltage	3	5	5.5	Volt		Off Control Voltage			0.8	Volt		F <sub>FWM</sub>	Dimming Frequency	200	-	20k	[Hz]		Swing Voltage	3	3.3	5	V		High Voltage	3	3.3	5.5	Volt		Low Voltage			0.8	Volt			Dimming Duty Cycle	5	-	100	%		I <sub>f</sub>	LED Forward Current		45		mA	Ta = 25°C	V <sub>f</sub>	LED Forward Voltage	-	3.2	3.6	Volt	I <sub>f</sub> 50=mA, Ta = 25°C	P <sub>LED</sub>	LED Power Consumption	-		6.804	Watt	I <sub>f</sub> 50=mA, Ta = 25°C	Operation Lifetime		50,000			Hrs	I <sub>f</sub> 50=mA, Ta = 25°C
Symbol	Parameter	Min.	Typ.	Max.	Unit	Remark																																																																																																																																																																																																																					
VCC	Input Voltage	10.8	12	13.2	[Volt]																																																																																																																																																																																																																						
I <sub>VCC</sub>	Input Current		0.75	1	[A]	100% PWM Duty																																																																																																																																																																																																																					
P <sub>VCC</sub>	Power Consumption		9	13.2	[Watt]	100% PWM Duty																																																																																																																																																																																																																					
I <sub>rush LED</sub>	Inrush Current	-	-	3	[A]	at rising time=470us																																																																																																																																																																																																																					
V <sub>LED on/off</sub>	On Control Voltage	3	5	5.5	Volt																																																																																																																																																																																																																						
	Off Control Voltage			0.8	Volt																																																																																																																																																																																																																						
F <sub>FWM</sub>	Dimming Frequency	200	-	20k	[Hz]																																																																																																																																																																																																																						
	Swing Voltage	3	3.3	5	V																																																																																																																																																																																																																						
	High Voltage	3	3.3	5.5	Volt																																																																																																																																																																																																																						
	Low Voltage			0.8	Volt																																																																																																																																																																																																																						
	Dimming Duty Cycle	5	-	100	%																																																																																																																																																																																																																						
I <sub>f</sub>	LED Forward Current		45		mA	Ta = 25°C																																																																																																																																																																																																																					
V <sub>f</sub>	LED Forward Voltage	-	3.2	3.6	Volt	I <sub>f</sub> 50=mA, Ta = 25°C																																																																																																																																																																																																																					
P <sub>LED</sub>	LED Power Consumption	-		6.804	Watt	I <sub>f</sub> 50=mA, Ta = 25°C																																																																																																																																																																																																																					
Operation Lifetime		50,000			Hrs	I <sub>f</sub> 50=mA, Ta = 25°C																																																																																																																																																																																																																					
Symbol	Parameter	Min.	Typ.	Max.	Unit	Remark																																																																																																																																																																																																																					
VCC	Input Voltage	10.8	12	13.2	[Volt]																																																																																																																																																																																																																						
I <sub>VCC</sub>	Input Current		0.5	0.6	[A]	100% PWM Duty																																																																																																																																																																																																																					
P <sub>VCC</sub>	Power Consumption		6	7.92	[Watt]	100% PWM Duty																																																																																																																																																																																																																					
I <sub>rush LED</sub>	Inrush Current	-	-	3	[A]	at rising time=470us																																																																																																																																																																																																																					
V <sub>LED on/off</sub>	On Control Voltage	3	5	5.5	Volt																																																																																																																																																																																																																						
	Off Control Voltage			0.8	Volt																																																																																																																																																																																																																						
F <sub>FWM</sub>	Dimming Frequency	200	-	20k	[Hz]																																																																																																																																																																																																																						
	Swing Voltage	3	3.3	5	V																																																																																																																																																																																																																						
	High Voltage	3	3.3	5.5	Volt																																																																																																																																																																																																																						
	Low Voltage			0.8	Volt																																																																																																																																																																																																																						
	Dimming Duty Cycle	5	-	100	%																																																																																																																																																																																																																						
I <sub>f</sub>	LED Forward Current		45		mA	Ta = 25°C																																																																																																																																																																																																																					
V <sub>f</sub>	LED Forward Voltage	-	3.2	3.6	Volt	I <sub>f</sub> 50=mA, Ta = 25°C																																																																																																																																																																																																																					
P <sub>LED</sub>	LED Power Consumption	-		6.804	Watt	I <sub>f</sub> 50=mA, Ta = 25°C																																																																																																																																																																																																																					
Operation Lifetime		50,000			Hrs	I <sub>f</sub> 50=mA, Ta = 25°C																																																																																																																																																																																																																					

## 1.0 Handling Precautions

- 1) Since front polarizer is easily damaged, pay attention not to scratch it.
- 2) Be sure to turn off power supply when inserting or disconnecting from input connector.
- 3) Wipe off water drop immediately. Long contact with water may cause discoloration or spots.
- 4) When the panel surface is soiled, wipe it with absorbent cotton or other soft cloth.
- 5) Since the panel is made of glass, it may break or crack if dropped or bumped on hard surface.
- 6) Since CMOS LSI is used in this module, take care of static electricity and insure human earth when handling.
- 7) Do not open or modify the Module Assembly.
- 8) Do not press the reflector sheet at the back of the module to any directions.
- 9) In case if a Module has to be put back into the packing container slot after it was taken out from the container, do not press the center of LED lightbar edge. Instead, press at the far ends of the LED light bar edge softly. Otherwise the TFT Module may be damaged.
- 10) At the insertion or removal of the Signal Interface Connector, be sure not to rotate nor tilt the Interface Connector of the TFT Module.
- 11) After installation of the TFT Module into an enclosure, do not twist nor bend the TFT Module even momentarily. While designing the enclosure, it should be taken into consideration that no bending/twisting forces are applied to the TFT Module from outside. Otherwise the TFT Module may be damaged.
- 12) Small amount of materials having no flammability grade is used in the LCD module. The LCD module should be supplied by power complied with requirements of Limited Power Source (IEC60950-1 or UL1950-1), or be applied exemption.



## 2.0 General Description

This specification applies to the 18.5 inch-wide Color a-Si TFT-LCD Module G185XW01 V201. The display supports the WXGA [1366(H) x 768(V)] screen format and 16.7M colors (RGB 6-bits + Hi-FRC data). All input signals are LVDS interface compatible.

## 2.1 Display Characteristics

The following items are characteristics summary on the table under 25°C condition:

ITEMS	Unit	SPECIFICATIONS
Screen Diagonal	[mm]	470.1(18.51")
Active Area	[mm]	409.8 (H) x 230.4 (V)
Pixels H x V		1366(x3) x 768
Pixel Pitch	[um]	300 (per one triad) x 300
Pixel Arrangement		R.G.B. Vertical Stripe
Display Mode		TN Mode, Normally White
White Luminance ( Center )	[cd/m <sup>2</sup> ]	450 cd/m <sup>2</sup> (Typ.)
Contrast Ratio		1000 (Typ.)
Optical Response Time	[msec]	8ms (Typ., on/off)
Nominal Input Voltage VDD	[Volt]	+5.0 V (Typ)
Power Consumption (VDD line + LED line)	[Watt]	8.25W (Typ.) (Pdd=2.25W, PLED=6W)
Weight	[Grams]	1440 (Max)
Physical Size	[mm]	430.4 (W) x 254.7 (H) Typ. x 10.6 (D)Typ
Electrical Interface		One channel LVDS
Support Color		16.7M colors, RGB 6-bit +Hi- FRC
Surface Treatment		Anti-Glare, 3H
RoHS Compliance		RoHS Compliance
Temperature Range		0 to +60(+60°C as panel surface temperature)
Operating	[°C]	-20 to +60
Storage (Shipping)	[°C]	

## 2.2 Optical Characteristics

The optical characteristics are measured under stable conditions at 25 °C:

Item	Unit	Conditions	Min.	Typ.	Max.	Note
Viewing Angle	[degree]	Horizontal (Right) CR = 10 (Left)	150	170	- -	<b>2</b>
		Vertical (Up) CR = 10 (Down)	140	160	- -	
Contrast ratio		Normal Direction	600	1000	-	<b>3</b>
Response Time	[msec]	Raising Time (T <sub>IR</sub> )	-	5		<b>4</b>
		Falling Time (T <sub>IF</sub> )	-	3		
		Raising + Falling	-	8		
Color / Chromaticity Coordinates (CIE)		Red x	0.594	0.644	0.694	<b>5</b>
		Red y	0.283	0.333	0.383	
		Green x	0.270	0.320	0.370	
		Green y	0.567	0.617	0.667	
		Blue x	0.109	0.159	0.209	
		Blue y	0.018	0.068	0.118	
Color Coordinates (CIE) White		White x	0.263	0.313	0.363	<b>5</b>
		White y	0.279	0.329	0.379	
Central Luminance	[cd/m <sup>2</sup> ]		360	450	-	<b>6</b>
Luminance Uniformity	[%]		65	70	-	<b>7</b>
Crosstalk (in 60Hz)	[%]				2	<b>8</b>
Flicker	dB				-20	<b>9</b>
Color Gamut	%			70		

**Note 1: Measurement method**

The LCD module should be stabilized at given temperature for 30 minutes to avoid abrupt temperature change during measuring (at surface 35°C). In order to stabilize the luminance, the measurement should be executed after lighting Backlight for 30 minutes in a stable, windless and dark room.

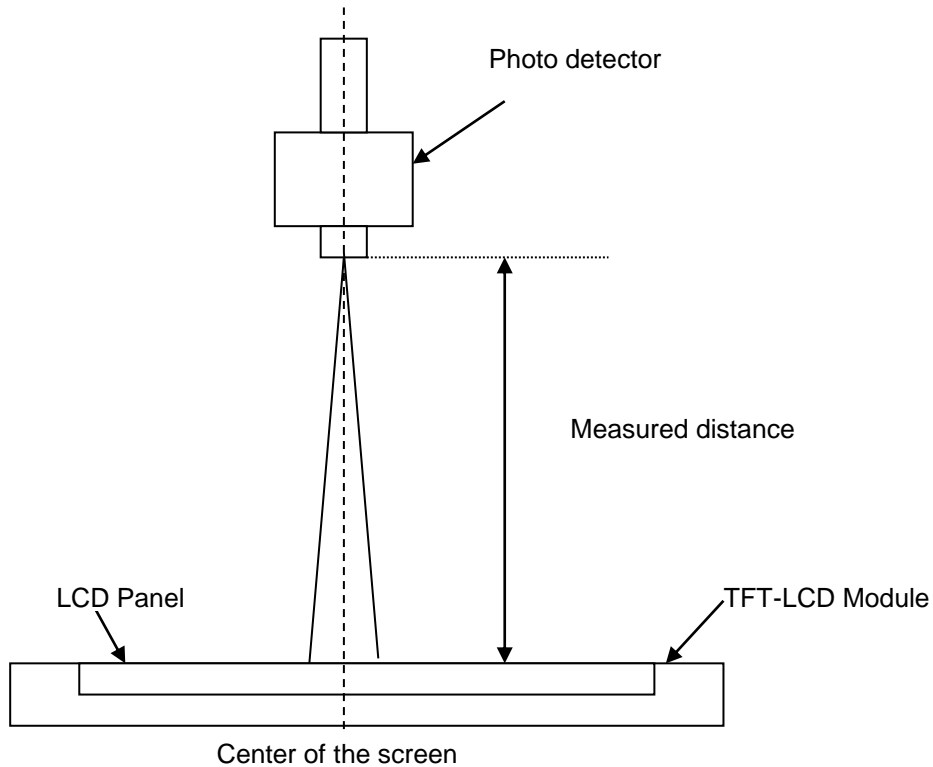

**Note 2: Definition of viewing angle** measured by ELDIM (EZContrast 88)

Viewing angle is the measurement of contrast ratio  $\geq 10$ , at the screen center, over a 180° horizontal and 180° vertical range (off-normal viewing angles). The 180° viewing angle range is broken down as follows; 90° ( $\theta$ ) horizontal left and right and 90° ( $\Phi$ ) vertical, high (up) and low (down). The measurement direction is typically perpendicular to the display surface with the screen rotated about its center to develop the desired measurement viewing angle.

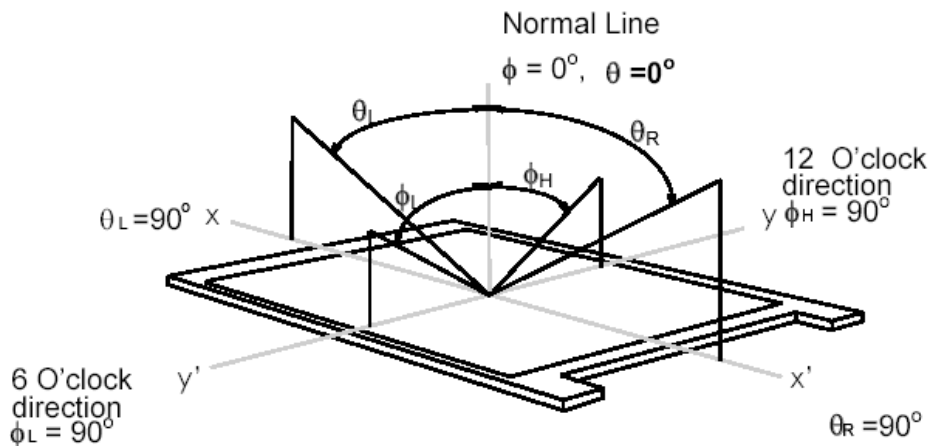

**Note 3: Contrast ratio** is measured by TOPCON SR-3

**Note 4: Definition of Response time** measured by Westar TRD-100A

The output signals of photo detector are measured when the input signals are changed from “Full Black” to “Full White” (rising time,  $Tr_R$ ), and from “Full White” to “Full Black” (falling time,  $Tf_F$ ), respectively. The response time is interval between the 10% and 90% (1 frame at 60 Hz) of amplitudes.  
 $Tr_R + Tf_F = 5 \text{ msec (typ.)}$ .

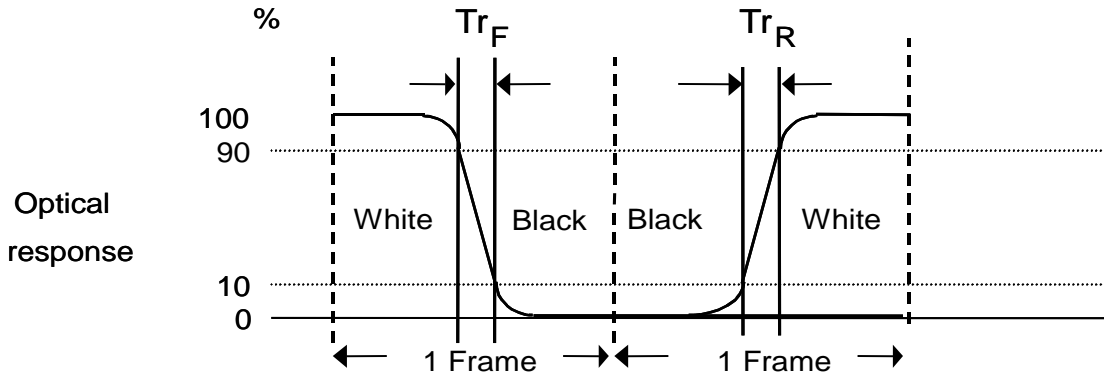

**Note 5: Color chromaticity and coordinates (CIE)** is measured by TOPCON SR-3

**Note 6: Central luminance** is measured by TOPCON SR-3

**Note 7: Luminance uniformity of these 9 points** is defined as below and measured by TOPCON SR-3

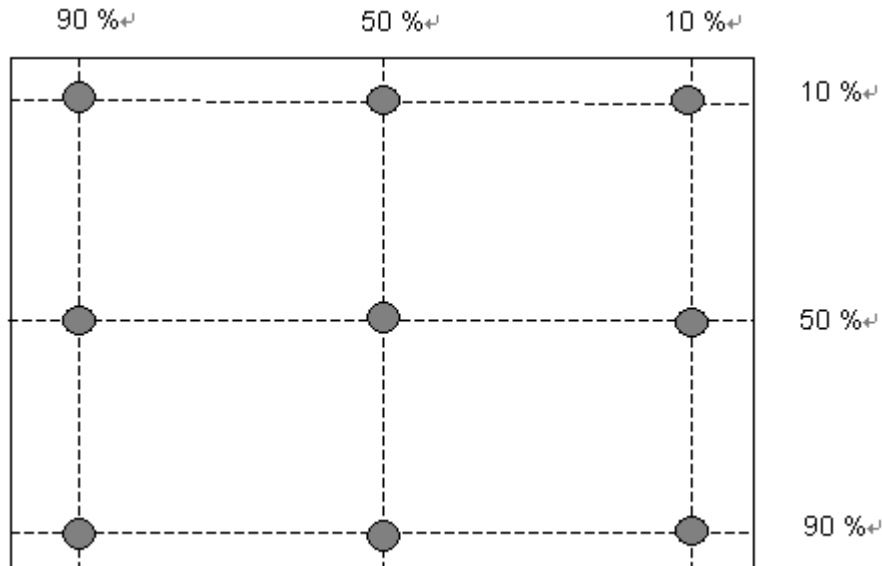

$$\text{Uniformity} = \frac{\text{Minimum Luminance in 9 points (1-9)}}{\text{Maximum Luminance in 9 Points (1-9)}}$$

**Note 8: Crosstalk** is defined as below and measured by TOPCON SR-3

$$CT = |YB - YA| / YA \times 100 (\%)$$



Where

YA = Luminance of measured location without gray level 0 pattern (cd/m<sup>2</sup>)

YB = Luminance of measured location with gray level 0 pattern (cd/m<sup>2</sup>)

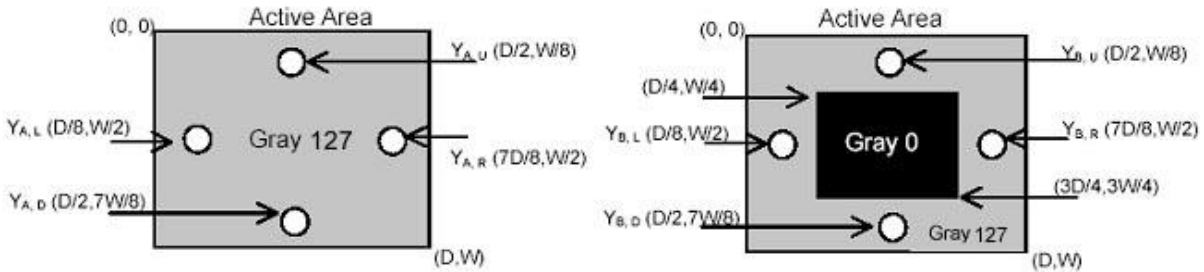

**Note 9: Test Pattern: Subchecker Pattern** measured by TOPCON SR-3

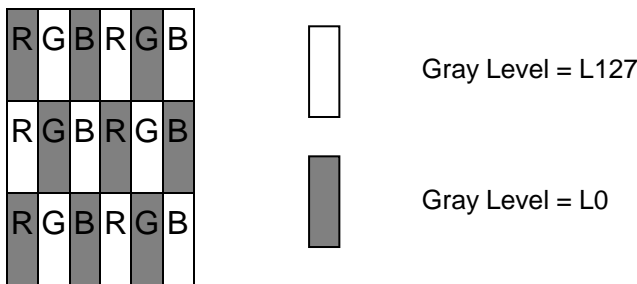

Method: Record dBV & DC value with TRD-100

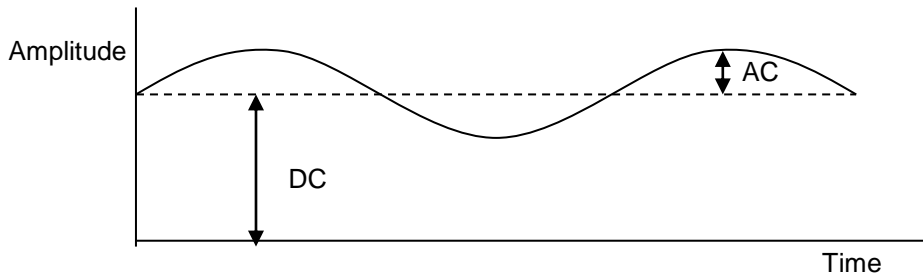

$$\text{Flicker (dB)} = 20 \log \frac{\text{AC Level(at 30 Hz)}}{\text{DC Level}}$$

### 3.0 Functional Block Diagram

The following diagram shows the functional block of the 18.5 inch Color TFT-LCD Module:

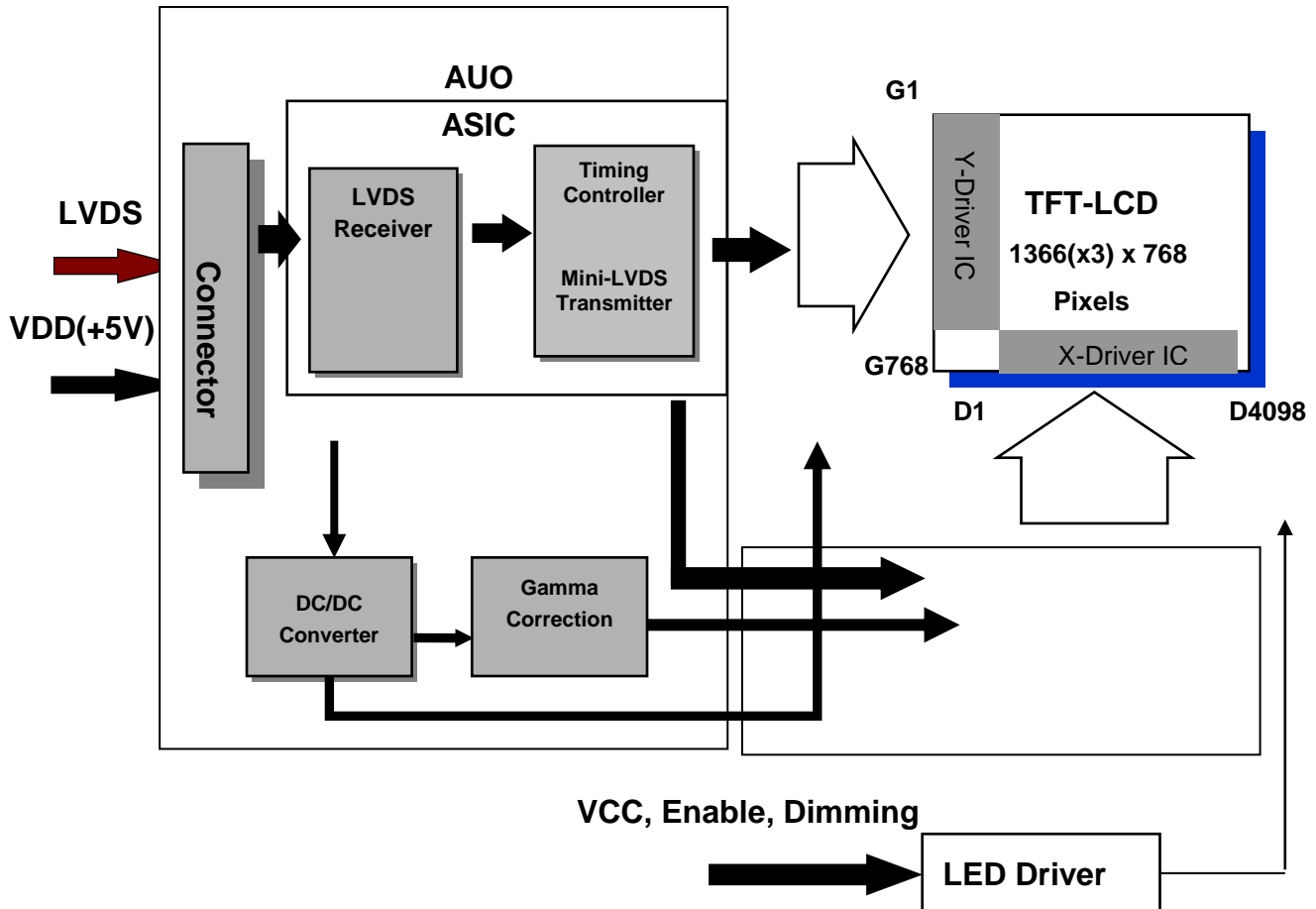

## 4.0 Absolute Maximum Ratings

Absolute maximum ratings of the module are as following:

### 4.1 TFT LCD Module

Item	Symbol	Min	Max	Unit	Conditions
Logic/LCD Drive Voltage	VDD	4.5	+5.5	[Volt]	<b>Note 1,2</b>

### 4.2 Absolute Ratings of Environment

Item	Symbol	Min.	Max.	Unit	Conditions
Operating Temperature	TOP	0	+60	[°C]	<b>Note 3 &amp; 4</b>
Operation Humidity	HOP	5	90	[%RH]	
Storage Temperature	TST	-20	+60	[°C]	
Storage Humidity	HST	5	90	[%RH]	

**Note 1:** With in Ta (25 °C)

**Note 2:** Permanent damage to the device may occur if exceeding maximum values

**Note 3:** For quality performance, please refer to AUO IIS(Incoming Inspection Standard).

**Note 4:** Operation Temperature + 50°C is defined as panel surface temperature.

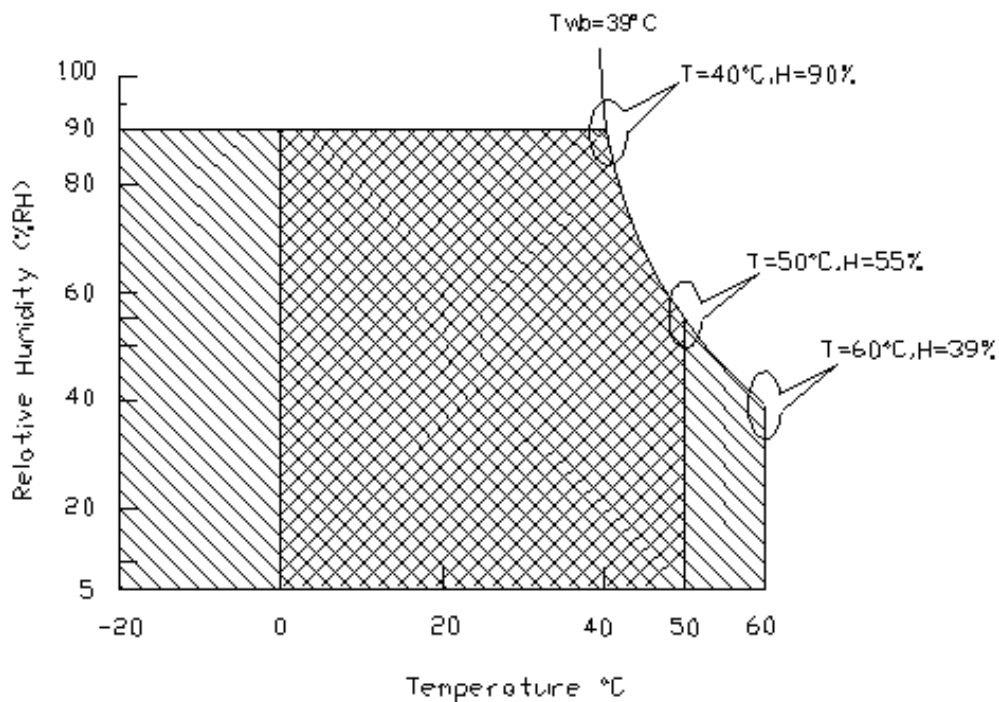

Operating Range



Storage Range



## 5.0 Electrical characteristics

### 5.1 TFT LCD Module

#### 5.1.1 Power Specification

Input power specifications are as follows:

Symbol	Parameter	Min	Typ	Max	Unit	Conditions
VDD	Logic/LCD Drive Voltage	4.5	5.0	5.5	[Volt]	+/-10%
IDD	Input Current	-	0.45	0.55	[A]	VDD= 5.0V, All Black Pattern At 60Hz,
PDD	VDD Power	-	2.25	3	[Watt]	VDD= 5.0V, All Black Pattern At 60Hz
IRush	Inrush Current	-	-	3	[A]	Note 1
VDDrp	Allowable Logic/LCD Drive Ripple Voltage	-	-	200	[mV] p-p	VDD= 5.0V, All Black Pattern At 60Hz

Note 1: Measurement conditions:

The duration of rising time of power input is 470us.

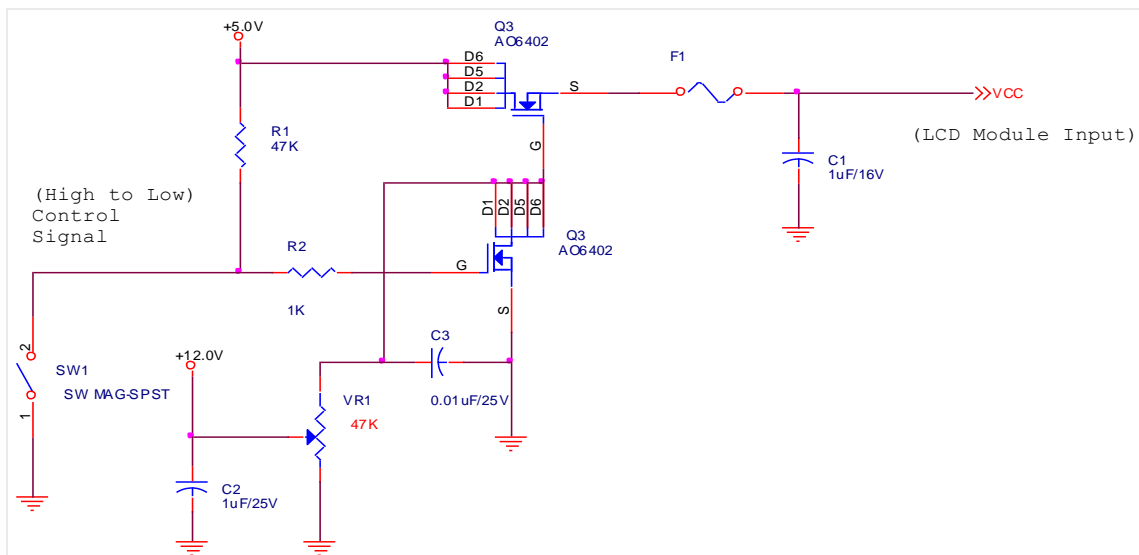

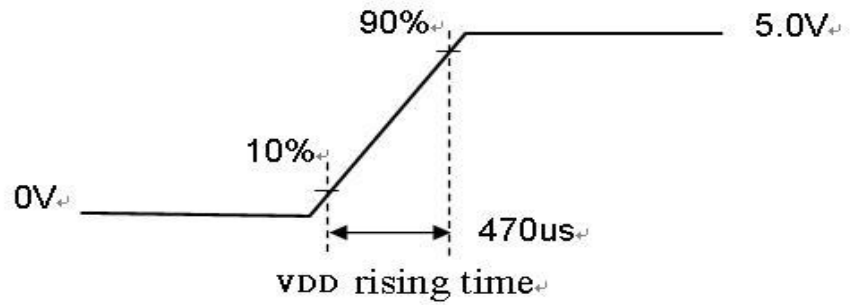

## 5.1.2 Signal Electrical Characteristics

Input signals shall be low or Hi-Z state when VDD is off. Please refer to specifications of SN75LVDS82DGG (Texas Instruments) in detail.

Characteristics of each signal are as follows:

Symbol	Parameter	Min	Typ	Max	Units	Condition
VTH	Differential Input High Threshold	-	+50	+100	[mV]	VICM = 1.2V <b>Note 1</b>
VTL	Differential Input Low Threshold	-100	-50	-	[mV]	VICM = 1.2V <b>Note 1</b>
VID	Input Differential Voltage	100	400	600	[mV]	<b>Note 1</b>
VICM	Differential Input Common Mode Voltage	+1.0	+1.2	+1.4	[V]	VTH-VTL = 200mV (max) <b>Note 1</b>

**Note 1:** LVDS Signal Waveform

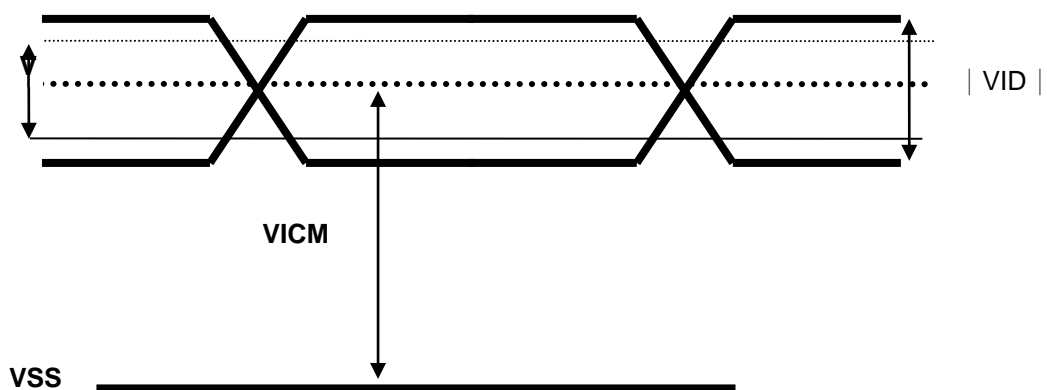

## 5.2 Backlight Unit

Following characteristics are measured under a stable condition at 25 °C (Room Temperature):

Symbol	Parameter	Min.	Typ.	Max.	Unit	Remark
<b>VCC</b>	Input Voltage	10.8	12	13.2	[Volt]	
<b>I<sub>VCC</sub></b>	Input Current		0.5	0.6	[A]	100% PWM Duty
<b>P<sub>VCC</sub></b>	Power Consumption		6	7.92	[Watt]	100% PWM Duty
<b>I<sub>rush LED</sub></b>	Inrush Current	-		3	[A]	at rising time=470us
<b>V<sub>LED on/off</sub></b>	On Control Voltage	3	5	5.5	Volt	
	Off Control Voltage			0.8	Volt	
<b>F<sub>PWM</sub></b>	Dimming Frequency	200	-	20k	[Hz]	
	Swing Voltage	3	3.3	5	V	
	High Voltage	3	3.3	5.5	Volt	
	Low Voltage			0.8	Volt	
	Dimming Duty Cycle	5	-	100	%	
<b>I<sub>F</sub></b>	LED Forward Current		45		mA	Ta = 25 °C
<b>V<sub>F</sub></b>	LED Forward Voltage	-	3.2	3.6	Volt	I <sub>F</sub> 50=mA, Ta = 25°C
<b>P<sub>LED</sub></b>	LED Power Consumption	-		6.804	Watt	I <sub>F</sub> 50=mA, Ta = 25°C
<b>Operation Lifetime</b>		50,000			Hrs	I <sub>F</sub> 50=mA, Ta= 25°C

*Note 1:* Ta means ambient temperature of TFT-LCD module.

*Note 2:* VCC, I<sub>VCC</sub>, P<sub>VCC</sub>, I<sub>rush LED</sub> are defined for LED B/L.(100% duty of PWM dimming)

*Note 3:* I<sub>F</sub>, V<sub>F</sub>, P<sub>LED</sub> are defined for single LED.

*Note 4:* If G185XW01 V201 module is driven by high current or at high ambient temperature & humidity condition. The operating life will be reduced.

*Note 5:* Operation life means brightness goes down to 50% initial brightness. Minimum operating life time is estimated data.

*Note 6:* Each LED light bar consists of 42 pcs LED package (6 strings x 7 pcs / string)

## 6.0 Signal Characteristic

### 6.1 Pixel Format Image

Following figure shows the relationship of the input signals and LCD pixel format.

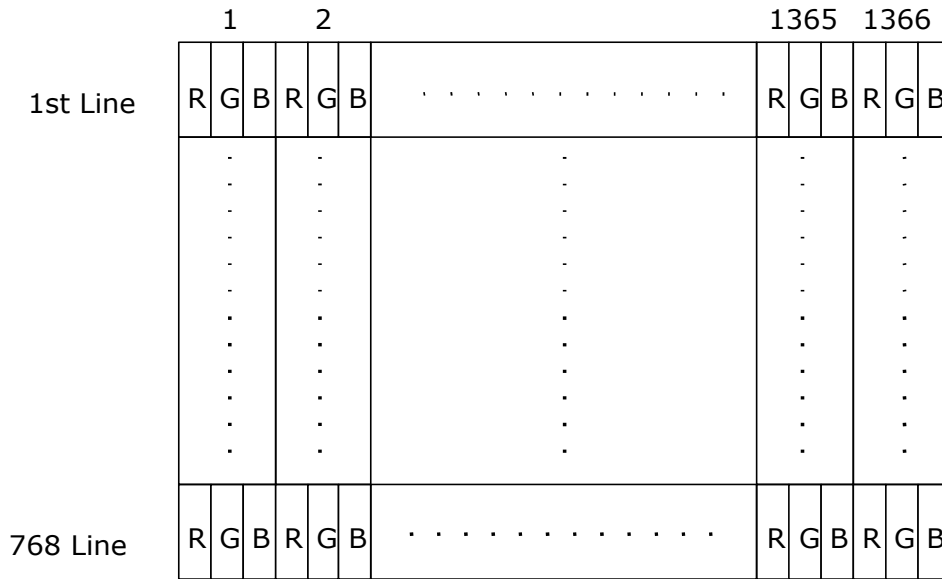

### 6.2 The input data format

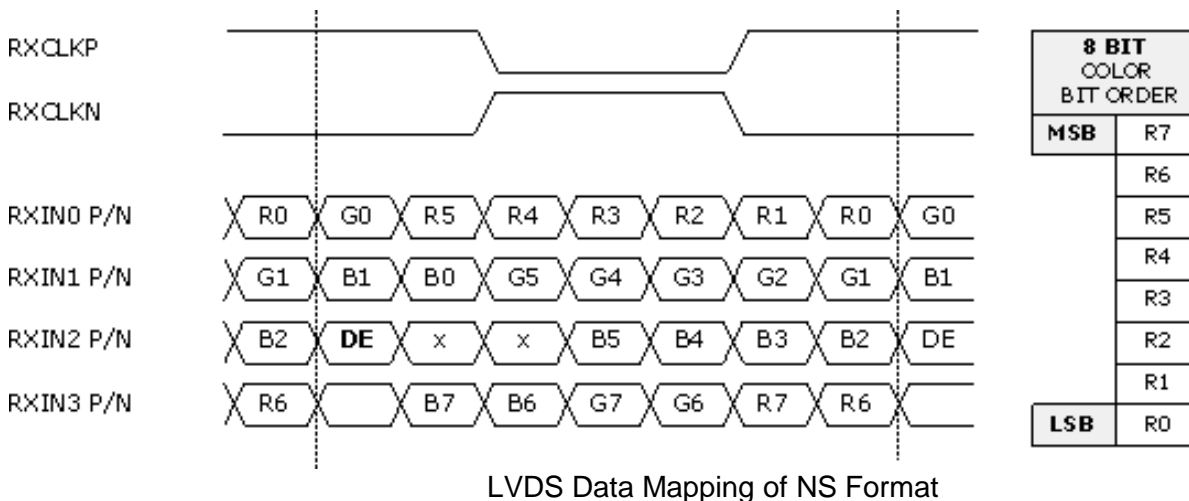

Note1: Normally, DE, VS, HS on EVEN channel are not used.

Note2: 8-bits signal input.

## 6.3 Signal Description

The module using one LVDS receiver SN75LVDS82(Texas Instruments). LVDS is a differential signal technology for LCD interface and high speed data transfer device. LVDS transmitters shall be SN75LVDS83(negative edge sampling). The first LVDS port(RxOxxx) transmits odd pixels while the second LVDS port(RxExxx) transmits even pixels.

PIN #	SIGNAL NAME	DESCRIPTION
1	NC	No contact (For AUO internal use)
2	NC	No contact (For AUO internal use)
3	NC	No contact (For AUO internal use)
4	GND	Power Ground
5	RXIN0-	Negative LVDS differential data input (0)
6	RXIN0+	Positive LVDS differential data input (0)
7	GND	Power Ground
8	RXIN1-	Negative LVDS differential data input (1)
9	RXIN1+	Positive LVDS differential data input (1)
10	GND	Power Ground
11	RXIN2-	Negative LVDS differential data input (2)
12	RXIN2+	Positive LVDS differential data input (2)
13	GND	Power Ground
14	RXCLKIN-	Negative LVDS differential clock input (clock)
15	RXCLKIN+	Positive LVDS differential data input (clock)
16	GND	Power Ground
17	RXIN3-	Negative LVDS differential data input (3)
18	RXIN3+	Positive LVDS differential data input (3)
19	GND	Power Ground
20	NC	No contact (For AUO internal use)
21	NC	No contact (For AUO internal use)
22	NC	No contact (For AUO internal use)
23	GND	Power Ground
24	GND	Power Ground
25	GND	Power Ground
26	VDD	+5V power supply
27	VDD	+5V power supply
28	VDD	+5V power supply
29	VDD	+5V power supply
30	VDD	+5V power supply



Note1: Start from left side

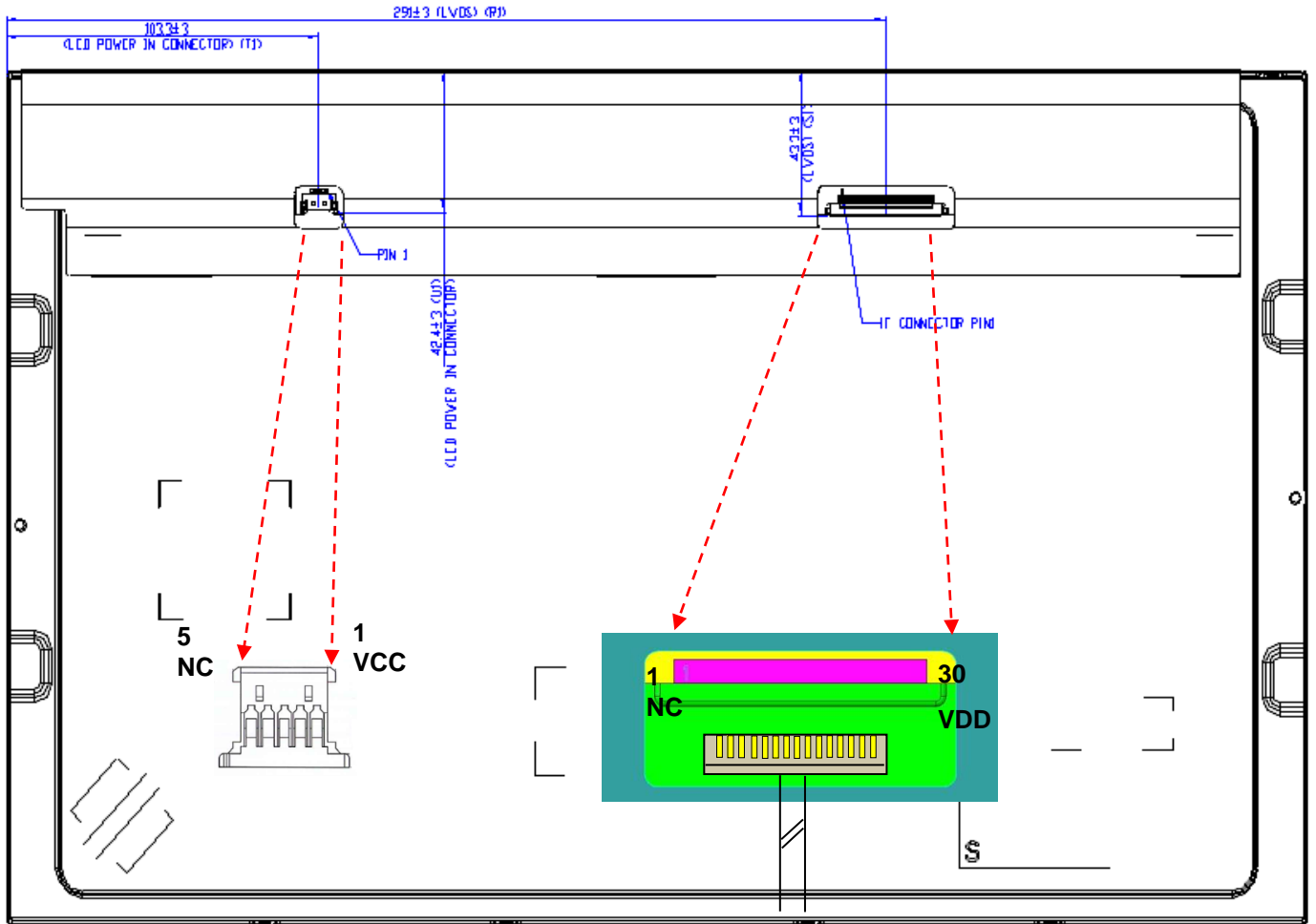

Note2: Input signals of clock shall be the same timing.

Note3: Please follow TV VESA Pin Assignment.

## 6.4 Timing Characteristics

Basically, interface timing described here is not actual input timing of LCD module but close to output timing of SN75LVDS82DGG (Texas Instruments) or equivalent.

Signal	Item	Symbol	Min	Typ	Max	Unit
V-section	Period	T <sub>v</sub>	776	808	1023	Th
	Active	T <sub>disp(V)</sub>	768	768	768	Th
	Blanking	T <sub>vB</sub>	8	40	255	Th
H-section	Period	T <sub>H</sub>	1416	1606	2047	Tclk
	Active	T <sub>disp(H)</sub>	1366	1366	1366	Tclk
	Blanking	T <sub>HB</sub>	50	240	681	Tclk
Clock	Period	T <sub>clk</sub>	-	12.8	-	ns
	Frequency	1/T <sub>clk</sub>	-	78	90	MHz
Frame Rate	Frame Rate	F	50	60	75	Hz

Note1 : DE mode only

Note2 : Clock Frequency 90MHz(Max.)= 1416(H)\*847(V)\*75Hz

## 6.5 Timing diagram

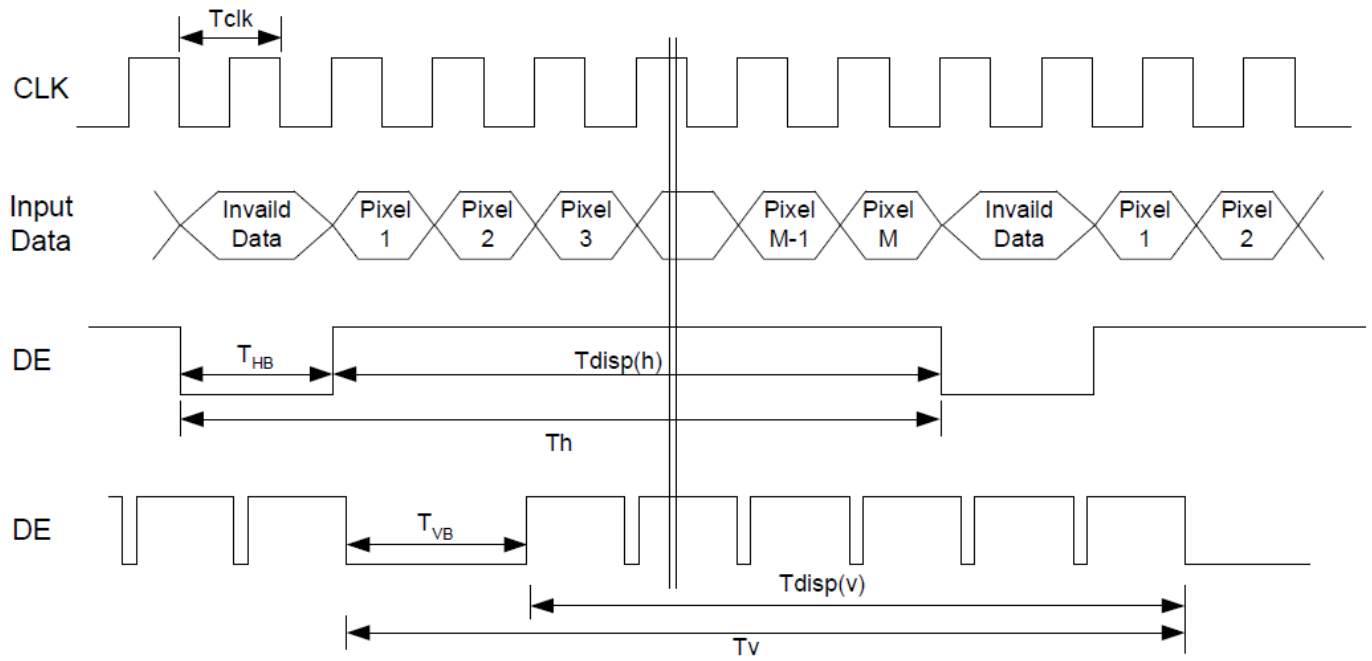

## 6.6 Power ON/OFF Sequence

VDD power and LED on/off sequence are as follows. Interface signals are also shown in the chart. Signals from any system shall be Hi-Z state or low level when VDD is off.

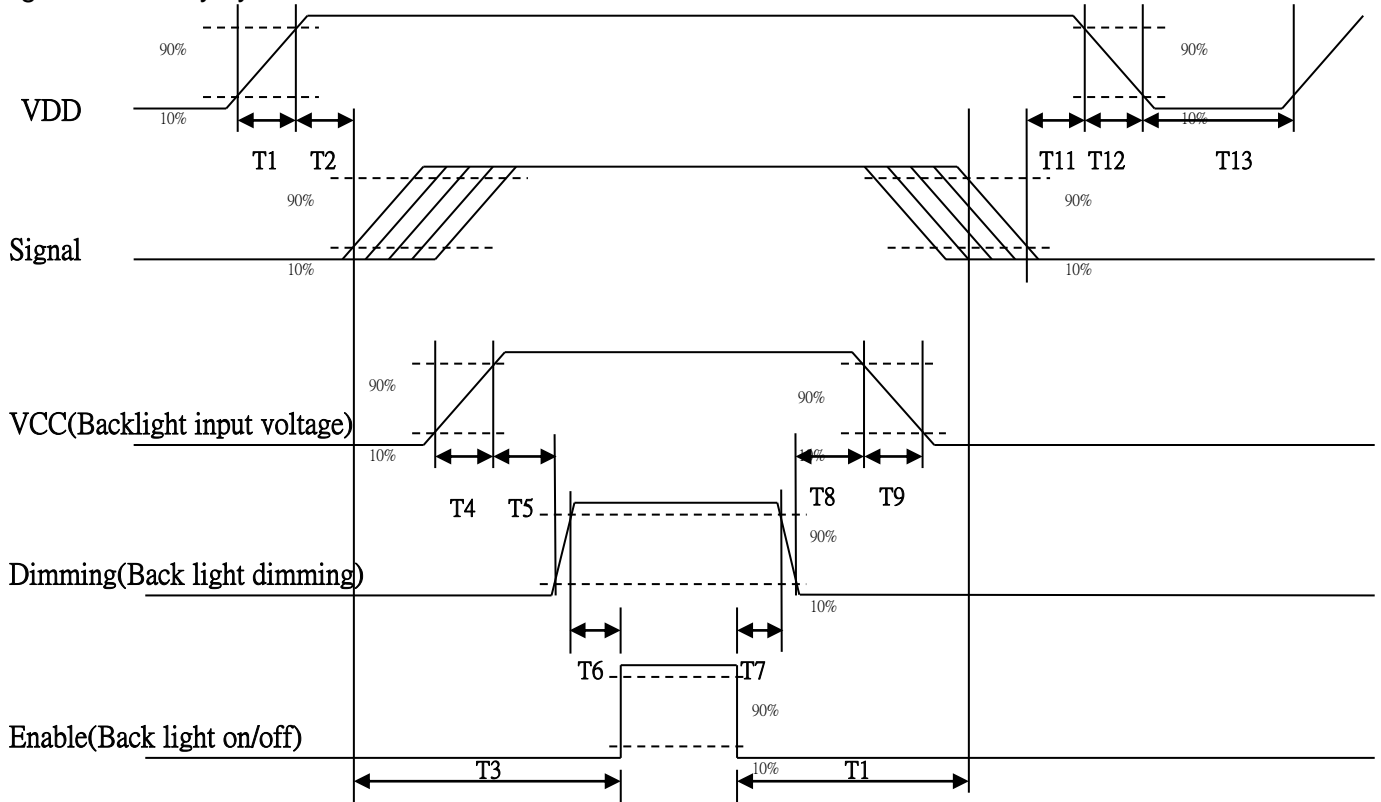

**Power ON/OFF sequence timing**

Parameter	Value			Units
	Min.	Typ.	Max.	
T1	0.5	-	10	[ms]
T2	0	40	50	[ms]
T3	200	-	-	[ms]
T4	0.5	-	10	[ms]
T5	10	-	-	[ms]
T6	10	-	-	[ms]
T7	0	-	-	[ms]
T8	10	-	-	[ms]
T9	-	-	10	[ms]
T10	110	-	-	[ms]
T11	0.5	16	50	[ms]
T12	-	-	100	[ms]
T13	1000	-	-	[ms]

## 7.0 Connector & Pin Assignment

Physical interface is described as for the connector on module. These connectors are capable of accommodating the following signals and will be following components.

### 7.1 TFT LCD Module

<b>Connector Name / Designation</b>	<b>Interface Connector / Interface card</b>
Manufacturer	STM
Type Part Number	MSBKT2407P30HB
Mating Housing Part Number	FI-X30HL(JAE) (Locked Type) FI-X30H (JAE)(Unlocked Type)

#### 7.1.1 Pin Assignment

Pin#	Signal Name	Pin#	Signal Name
1	NC	2	NC
3	NC	4	GND
5	RXIN0-	6	RXIN0+
7	GND	8	RXIN1-
9	RXIN1+	10	GND
11	RXIN2-	12	RXIN2+
13	GND	14	RXCLKIN-
15	RXCLKIN+	16	GND
17	RXIN3-	18	RXIN3+
19	GND	20	NC
21	NC	22	NC
23	GND	24	GND
25	GND	26	VDD
27	VDD	28	VDD
29	VDD	30	VDD

### 7.2 LED Backlight Unit: LED Driver Connector

<b>Connector Name / Designation</b>	<b>LED Connector</b>
Manufacturer	E&T or compatible
Connector Model Number	3808K-F05N-06L or compatible
Mating Connector Model Number	H208K-P05N-02B or compatible

## 7.3 LED Driver Connector Pin Assignment

Pin#	Symbol	Signal Name
1	VCC	12V
2	GND	GND
3	Enable	5V-On / 0V-Off
4	Dimming	PWM Dimming
5	NC	NC

## 8.0 Reliability Test

Environment test conditions are listed as following table.

Items	Required Condition	Note
Temperature Humidity Bias (THB)	Ta= 50°C, 80%RH, 300hours	
High Temperature Operation (HTO)	Ta= 60°C, 300hours	
Low Temperature Operation (LTO)	Ta= 0°C, 300hours	
High Temperature Storage (HTS)	Ta= 60°C, 300hours	
Low Temperature Storage (LTS)	Ta= -20°C, 300hours	
Vibration Test (Non-operation)	Acceleration: 1.5 Grms Wave: Random Frequency: 10 - 200 Hz Sweep: 30 Minutes each Axis (X, Y, Z)	
Shock Test (Non-operation)	Acceleration: 50 G Wave: Half-sine Active Time: 20 ms Direction: ±X, ±Y, ±Z (one time for each Axis)	
Drop Test	Height: 60 cm, package test	
Thermal Shock Test (TST)	-20°C /30min, 60°C /30min, 100 cycles	<b>1</b>
On/Off Test	On/10sec, Off/10sec, 30,000 cycles	
ESD (Electro Static Discharge)	Contact Discharge: ± 8KV, 150pF(330Ω ) 1sec, 8 points, 25 times/ point.	<b>2</b>
	Air Discharge: ± 15KV, 150pF(330Ω ) 1sec 8 points, 25 times/ point.	
Altitude Test	Operation:10,000 ft Non-Operation:30,000 ft	

*Note 1:* The TFT-LCD module will not sustain damage after being subjected to 100 cycles of rapid temperature change. A cycle of rapid temperature change consists of varying the temperature from -20°C to 60°C, and back again. Power is not applied during the test. After temperature cycling, the unit is placed in normal room ambient for at least 4 hours before power on.

*Note 2:* According to EN61000-4-2 , ESD class B: Some performance degradation allowed. No data lost. Self-recoverable. No hardware failures.

## 9.0 Shipping Label & Packaging

### 9.1 Shipping Label

The label is on the panel as shown below:



*Note 1:* For Pb Free products, AUO will add  for identification.

*Note 2:* For RoHS compatible products, AUO will add  for identification.

*Note 3:* For China RoHS compatible products, AUO will add  for identification.

*Note 4:* The Green Mark will be presented only when the green documents have been ready by AUO Internal Green Team.



## 9.2 Packaging

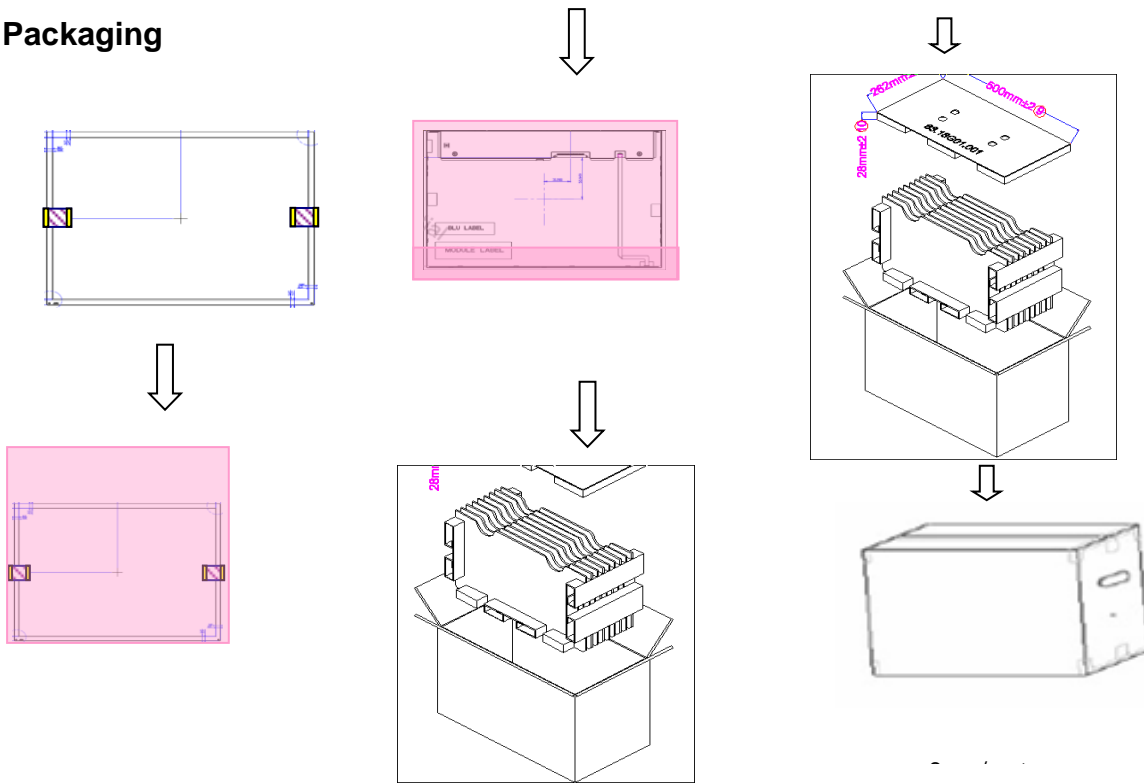

Max capacity : 8 TFT-LCD module per carton

Max weight: 15.0 kg per carton

Outside dimension of carton: 520mm(L)\* 280mm(W)\*355mm(H)

Pallet size : 1150 mm \*1070 mm \* 135mm

Box stacked

By air\_max : (2 \*4) \*4 layers , one pallet put 32 boxes , total 256pcs module

By sea\_max : (2 \*4) \*4 layers + (2 \*4) \*1 layers , two pallet put 40 boxes , total 320pcs module

By sea\_HQ\_max : (2 \*4) \*4 layers+(2 \*4) \*2 layers, two pallet put 48 boxes, total 384pcs module

### 9.3 Palletizing

	MAX SHIPPING BY AIR	MAX SHIPPING BY SEA	MAX SHIPPING BY SEA_HQ
MODULE/CARTON	8	8	8
CARTON/LAYER	8	8	8
LAYER/PALLET	4	4+1	4+2
MODULE/PALLET	256	320	384
CARTON SIZE(MM)	520(L)*280(W)*352(H)	520(L)*280(W)*352(H)	520(L)*280(W)*352(H)
PALLET SIZE(MM)	1140(L)*1060(W)*140(H)	1140(L)*1060(W)*140(H)	1140(L)*1060(W)*140(H)
TOTAL PALLET HEIGHT(MM)	1548	2040	2392
TOTAL PALLET WEIGHT(KG)	493	626	746

The diagrams illustrate the palletizing process in three stages:

- STRETCH FILM:** A stack of modules on a pallet is wrapped with stretch film.
- CORNER ANGLE:** The wrapped pallet is secured with corner angles.
- PET BAND:** The pallet is further secured with PET bands.

Shipping examples:

- ONE PALLET SHIPMENT EXAMPLE SHIPPING BY AIR USED:** Shows a single pallet configuration.
- TWO PALLETS SHIPMENT EXAMPLE SHIPPING BY SEA USED:** Shows two pallets stacked on top of each other.
- TWO PALLETS SHIPMENT EXAMPLE SHIPPING BY SEA\_HQ USED:** Shows two pallets stacked on top of each other, with a different configuration.

Not drawing to the scale of 1:1. Dimensions are not shown with the intention to be used for any other purpose than the purpose of this document.

REV	COL	DESCRIPTION	BY	DATE
01	001	PACKAGE DRAWING	NA	2015/12/09



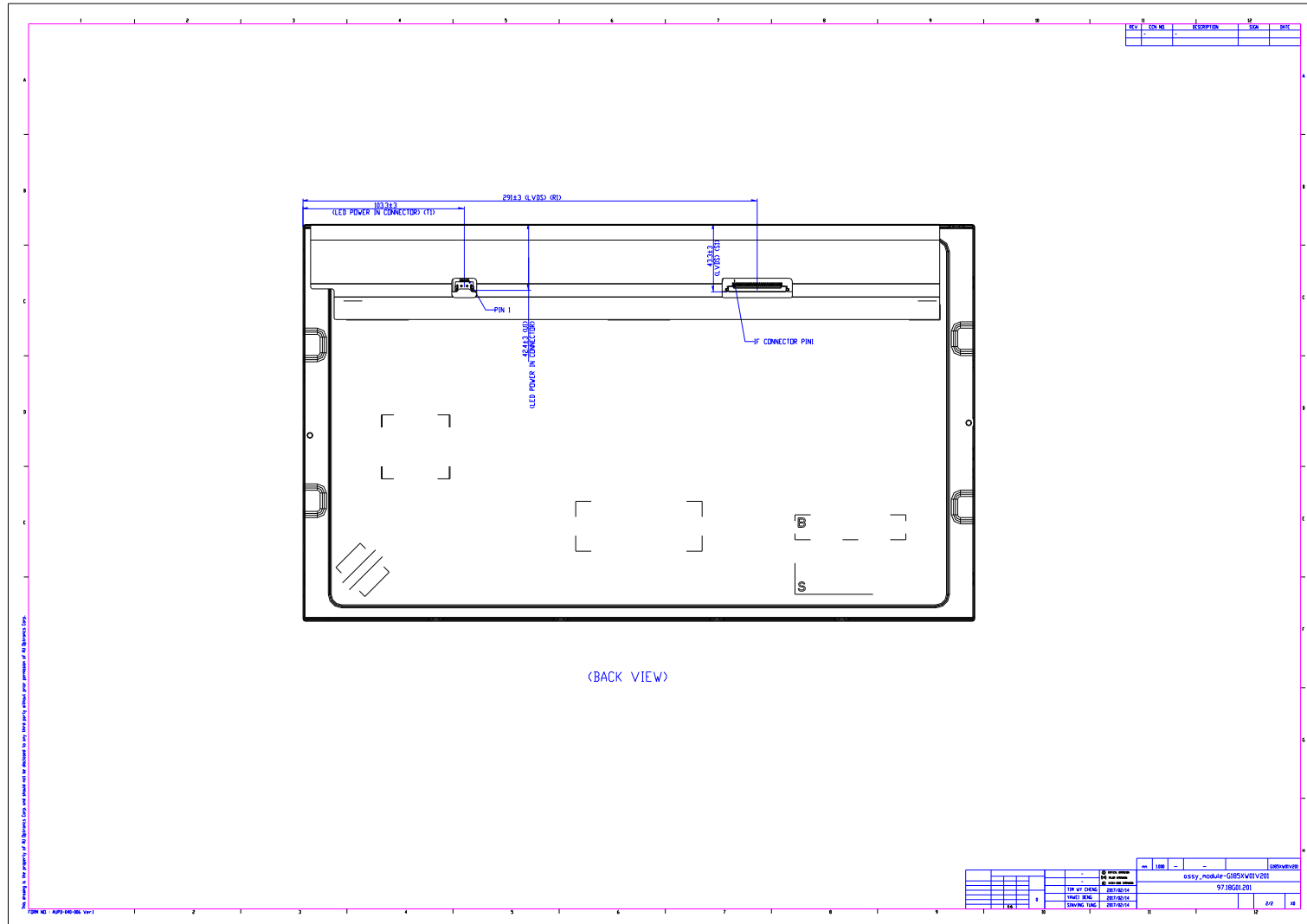

## 11 Safety

### 11.1 Sharp Edge Requirements

There will be no sharp edges or comers on the display assembly that could cause injury.

### 11.2 Materials

#### 11.2.1 Toxicity

There will be no carcinogenic materials used anywhere in the display module. If toxic materials are used, they will be reviewed and approved by the responsible AUO toxicologist.

#### 11.2.2 Flammability

All components including electrical components that do not meet the flammability grade UL94-V1 in the module will complete the flammability rating exception approval process.

The printed circuit board will be made from material rated 94-V1 or better. The actual UL flammability rating will be printed on the printed circuit board.

### 11.3 Capacitors

If any polarized capacitors are used in the display assembly, provisions will be made to keep them from being inserted backwards.

### 11.4 National Test Lab Requirement

The display module will satisfy all requirements for compliance to:

**UL 60950-1, Second Edition**

U.S.A. Information Technology Equipment