



( ) Preliminary Specification  
( V ) Final Specification

Module	19.0" Color TFT-LCD
Model Name	M190ETN01.0 (ES 8.0 from 00E)

Customer	Date
_____	_____
Approved by	
_____	_____

Note: This Specification is subject to change without notice.

Approved by	Date
<u><b>CH Lin</b></u>	<u>Nov 12, 2019</u>
Prepared by	Date
<u><b>Venus chen</b></u>	<u>Nov 12, 2019</u>

AU Optronics corporation

## Contents

<b>1 Handling Precautions</b> .....	<b>4</b>
<b>2 General Description</b> .....	<b>5</b>
2.1 Display Characteristics.....	5
2.2 Absolute Maximum Rating of Environment.....	7
2.3 Optical Characteristics .....	8
2.4 Mechanical Characteristics .....	11
<b>3 TFT-LCD Module</b> .....	<b>12</b>
3.1 Block Diagram.....	12
3.2 Interface Connection .....	12
3.2.1 Connector Type.....	12
3.2.2 Connector Pin Assignment .....	13
3.3 Electrical Characteristics.....	15
3.3.1 Absolute Maximum Rating.....	15
3.3.2 Recommended Operating Condition .....	15
3.4 Signal Characteristics .....	16
3.4.1 LCD Pixel Format.....	16
3.4.2 LVDS Data Format .....	16
3.4.3 Color versus Input Data.....	17
3.4.4 LVDS Specification.....	18
3.4.5 Input Timing Specification .....	20
3.4.6 Input Timing Diagram .....	21
3.5 Power ON/OFF Sequence .....	22
<b>4 Backlight Unit</b> .....	<b>22</b>
4.1 Block Diagram.....	23
4.2 Interface Connection .....	24
4.2.1 Connector Type.....	24
4.2.2 Connector Pin Assignment .....	26
4.3 Electrical Characteristics.....	27
4.3.1 Absolute Maximum Rating.....	27
4.3.2 Recommended Operating Condition .....	27
<b>5 Reliability Test</b> .....	<b>29</b>
<b>6 Shipping Label</b> .....	<b>30</b>
<b>7 Mechanical Characteristics</b> .....	<b>31</b>
<b>8 Packing Specification</b> .....	<b>32</b>
8.1 Packing Flow.....	32
8.2 Pallet and shipment information .....	33



## Record of Revision

Version	Date	Page	Old description	New Description	Remark
0.0	2019/7/3	All	First version for ES 8.0		
1.0	2019/11/12			Final verison	

## 1 Handling Precautions

- 1) Since front polarizer is easily damaged, pay attention not to scratch it.
- 2) Be sure to turn off power supply when inserting or disconnecting from input connector.
- 3) Wipe off water drop immediately. Long contact with water may cause discoloration or spots.
- 4) When the panel surface is soiled, wipe it with absorbent cotton or other soft cloth.
- 5) Since the panel is made of glass, it may break or crack if dropped or bumped on hard surface.
- 6) Since CMOS LSI is used in this module, take care of static electricity and insure human earth when handling.
- 7) Do not open or modify the Module Assembly.
- 8) Do not press the reflector sheet at the back of the module to any directions.
- 9) In case a TFT-LCD Module has to be put back into the packing container slot after once it was taken out from the container, do not press the center of the LED lightbar edge. Otherwise the TFT-LCD Module may be damaged.
- 10) Insert or pull out the interface connector, be sure not to rotate nor tilt it of the TFT-LCD Module.
- 11) Do not twist nor bend the TFT -LCD Module even momentary. It should be taken into consideration that no bending/twisting forces are applied to the TFT-LCD Module from outside. Otherwise the TFT-LCD Module may be damaged.
- 12) Please avoid touching COF position while you are doing mechanical design.
- 13) When storing modules as spares for a long time, the following precaution is necessary:  
Store them in a dark place. Do not expose the module to sunlight or fluorescent light. Keep the temperature between 5°C and 35°C at normal humidity.
- 14) When this reverse-type model(PCBA on bottom side) is used as forward-type model(PCBA on top side) , AUO can not guarantee any defects of LCM .
- 15) When this reverse-type model(PCBA on bottom side) is used as forward-type model(PCBA on top side) , AUO can not guarantee any defects of LCM.

## 2 General Description

This specification applies to the 19 inch SXGA Color a-Si TFT-LCD Module M190ETN01.0. The display supports the SXGA -1280(H) x 1024(V) screen format and 16.7M colors (8bits RGB data input). The input interface is Dual channel LVDS and this module doesn't contain an driver board for backlight.

### 2.1 Display Characteristics

The following items are characteristics summary on the table under 25°C condition:

ITEMS	Unit	SPECIFICATIONS
Screen Diagonal	[mm]	482.6 (19.0")
Active Area	[mm]	376.32 (H) x 301.056 (V)
Pixels H x V	-	1280(x3) x 1024
Pixel Pitch	[um]	294 (per one triad) x294
Pixel Arrangement	-	R.G.B. Vertical Stripe
Display Mode	-	TN Mode, Normally White
White Luminance ( Center )	[cd/m <sup>2</sup> ]	250 (Typ.) @ 50.0mA
Contrast Ratio	-	1000 (Typ.)
Response Time	[msec]	5 (Typ., on/off)
Power Consumption (LCD Module + Backligh unit)	[Watt]	8.8 (Typ.) LCD module : PDD (Typ.)=2.7 @ Black pattern,Fv=60Hz Backlight unit : P <sub>BLU</sub> (Typ.) =6.1
Weight	[Grams]	1700
Outline Dimension	[mm]	396(H) x 324(V) x 10.9(D) Typ.
Electrical Interface	-	Dual channel LVDS 8bits RGB data input
Support Color	-	16.7M colors
Surface Treatment	-	Anti-glare type,AG25%, Hardness 3H
Temperature Range		
Operating	[°C]	0 to +50
Storage (Shipping)	[°C]	-20 to +60
RoHS Compliance	-	RoHS Compliance
TCO Compliance	-	TCO 7.0 Compliance

**Note 2-1:** The following shows the figure of pixel arrangement

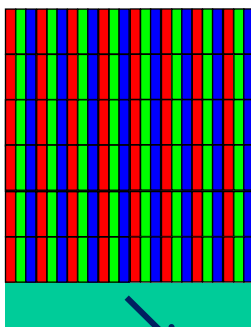

Source Board



# Product Specification

M190ETN01.0

AU OPTRONICS CORPORATION

## 2.2 Absolute Maximum Rating of Environment

Permanent damage may occur if exceeding the following maximum rating.

Symbol	Description	Min.	Max.	Unit	Remark
TOP	Operating Temperature	0	+50	[°C]	<b>Note 2-1</b>
TGS	Glass surface temperature (operation)	0	+65	[°C]	<b>Note 2-1</b> Function judged only
HOP	Operation Humidity	5	90	[%RH]	<b>Note 2-1</b>
TST	Storage Temperature	-20	+60	[°C]	
HST	Storage Humidity	5	90	[%RH]	

**Note 2-1:** Temperature and relative humidity range are shown as the below figure.

1. 90% RH Max (  $T_a \leq 39^\circ\text{C}$  )
2. Max wet-bulb temperature at  $39^\circ\text{C}$  or less. (  $T_a \leq 39^\circ\text{C}$  )
3. No condensation

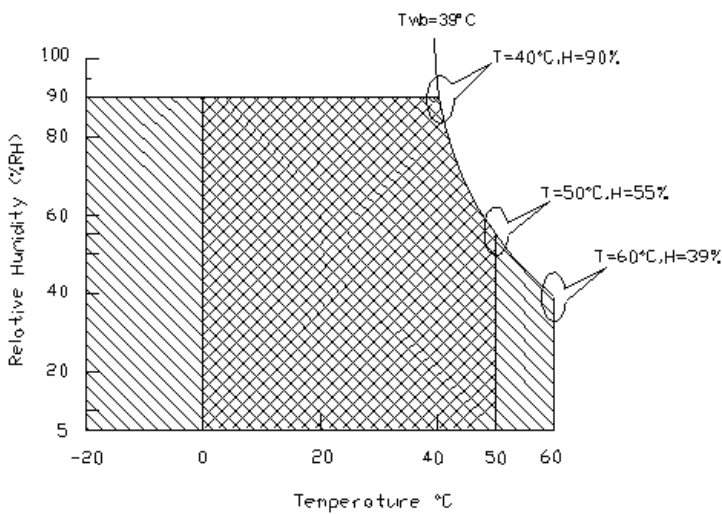

Operating Range



Storage Range

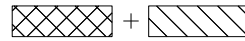

## 2.3 Optical Characteristics

The optical characteristics are measured on the following test condition.

### Test Condition:

1. Equipment setup: Please refer to **Note 2-3**.
2. Panel Lighting time: 30 minutes
3. VDD=5.0V, Fv=60Hz, Is=50mA, Ta=25°C

Symbol	Description		Min.	Typ.	Max.	Unit	Remark
$L_w$	White Luminance (Center of screen)		200	250	-	[cd/m <sup>2</sup> ]	<b>Note 2-3</b> By SR-3
$L_{uni}$	Luminance Uniformity (9 points)		75	80	-	[%]	<b>Note 2-4</b> By SR-3
CR	Contrast Ratio (Center of screen)		600	1000	-	-	<b>Note 2-5</b> By SR-3
$\theta_R$	Horizontal Viewing Angle (CR=10)	Right	75	85	-	[degree]	<b>Note 2-6</b> By SR-3
$\theta_L$		Left	75	85	-		
$\Phi_H$	Vertical Viewing Angle (CR=10)	Up	70	80	-		
$\Phi_L$		Down	70	80	-		
$\theta_R$	Horizontal Viewing Angle (CR=5)	Right	75	88	-		
$\theta_L$		Left	75	88	-		
$\Phi_H$	Vertical Viewing Angle (CR=5)	Up	70	85	-		
$\Phi_L$		Down	70	85	-		
$T_R$	Response Time	Rising Time	-	3.6	5.7	[msec]	<b>Note 2-7</b> By TRD-100
$T_F$		Falling Time	-	1.4	2.3		
-		Rising + Falling	-	5	8		
$R_x$	Color Coordinates (CIE 1931)	Red x	0.617	0.647	0.677	-	By SR-3
$R_y$		Red y	0.311	0.341	0.371		
$G_x$		Green x	0.296	0.326	0.356		
$G_y$		Green y	0.596	0.626	0.656		
$B_x$		Blue x	0.122	0.152	0.182		
$B_y$		Blue y	0.025	0.055	0.085		
$W_x$		White x	0.283	0.313	0.343		
$W_y$		White y	0.299	0.329	0.359		
NTSC				72		%	By SR-3



**Note 2-3:** Equipment setup :

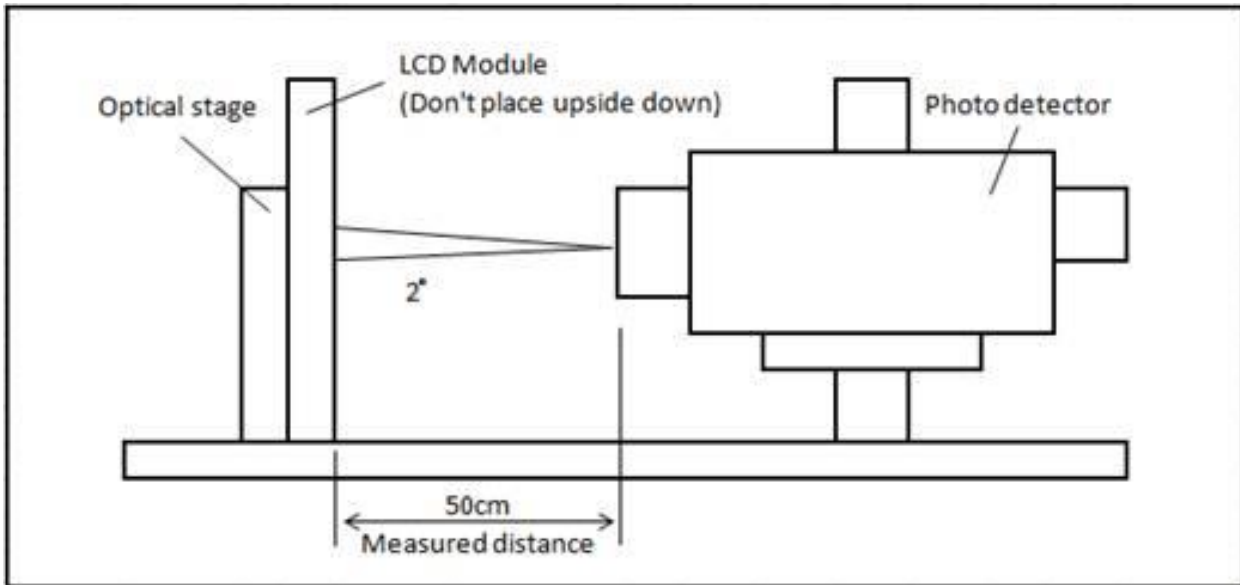

**Note 2-4:** Luminance Uniformity Measurement

**Definition:**

$$\text{Luminance Uniformity} = \frac{\text{Minimum Luminance of 9 Points (P1 ~ P9)}}{\text{Maximum Luminance of 9 Points (P1 ~ P9)}}$$

*a. Test pattern: White Pattern*

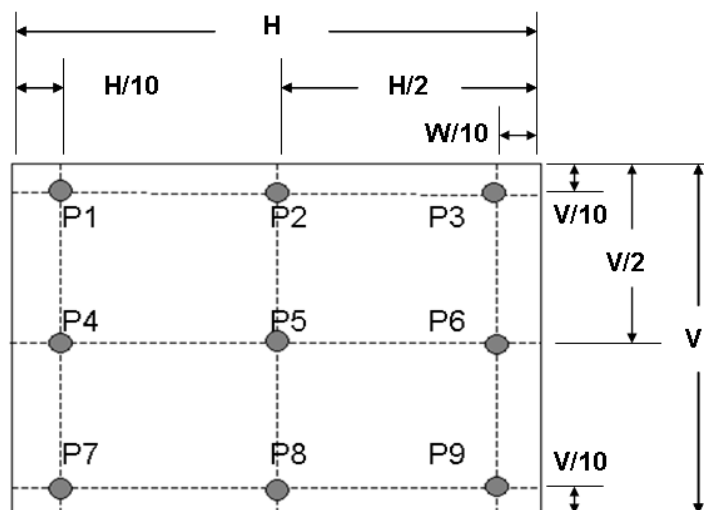

**Note 2-5:** Contrast Ratio Measurement

**Definition:**

$$\text{Contrast Ratio} = \frac{\text{Luminance of White pattern}}{\text{Luminance of Black pattern}}$$

- a. Measured position: Center of screen (P5) & perpendicular to the screen ( $\theta = \Phi = 0^\circ$ )

**Note 2-6:** Viewing angle measurement

**Definition:** The angle at which the contrast ratio is greater than 10 & 5 .

- a. Horizontal view angle: Divide to left & right ( $\theta_L$  &  $\theta_R$ )  
 Vertical view angle: Divide to up & down ( $\Phi_H$  &  $\Phi_L$ )

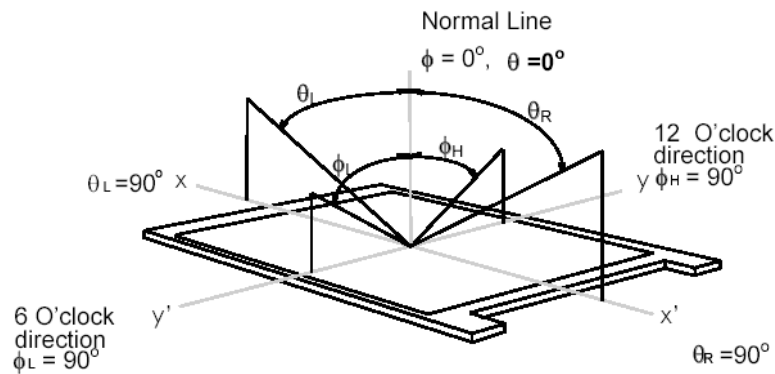

**Note 2-7:** Response time measurement

The output signals of photo detector are measured when the input signals are changed from “Black” to “White” (rising time,  $T_R$ ), and from “White” to “Black” (falling time,  $T_F$ ), respectively. The response time is interval between the 10% and 90% of optical response.  
*(Black & White color definition: Please refer section 3.4.3)*

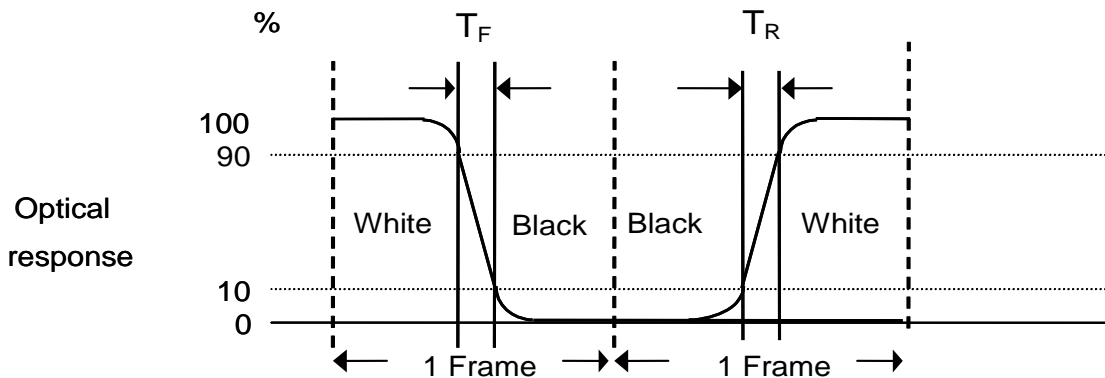

## 2.4 Mechanical Characteristics

Symbol	Description	Min.	Max.	Unit	Remark
P <sub>bc</sub>	Backside Compression	2.5	-	[Kgf]	<b>Note 2-8</b>

**Note 2-8:** Test Method:

The point is at a distance from right-downside 25mm x 25mm defined as the Start Point of Measure Points, and the point is at a distance 25mm from left-side & around 10mm from PCB defined as the End Point.

Align 50mm x 50mm block from Start Point on the Bezel Back, and the corners of each block are Measure Points.

If the distance from the last block to each side of the End Point  $\geq 25\text{mm}$ , add other blocks to make sure that most area of Bezel Back can be measured.

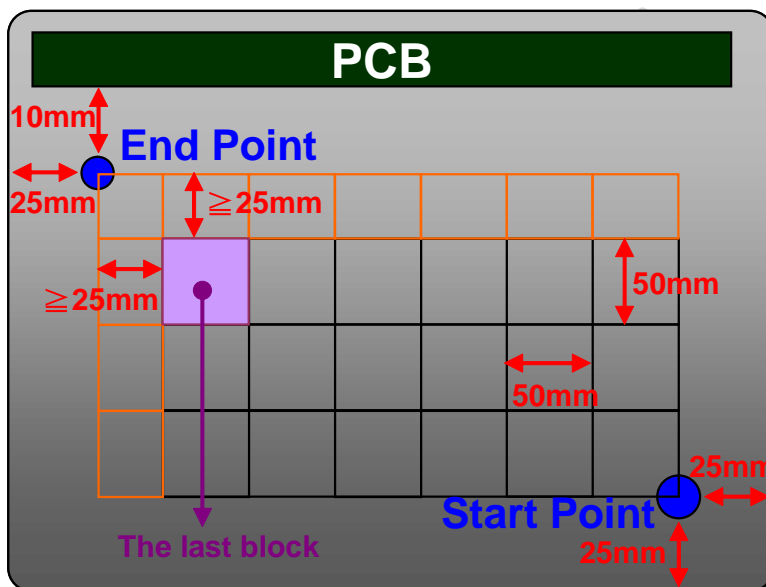

**Note 2-9:** Evaluation test and mass production inspection shall be applied with LED current I<sub>s</sub> @ HDR off condition if there is not specified condition.

## 3 TFT-LCD Module

### 3.1 Block Diagram

The following shows the block diagram of the 19.0 inch Color TFT-LCD Module.

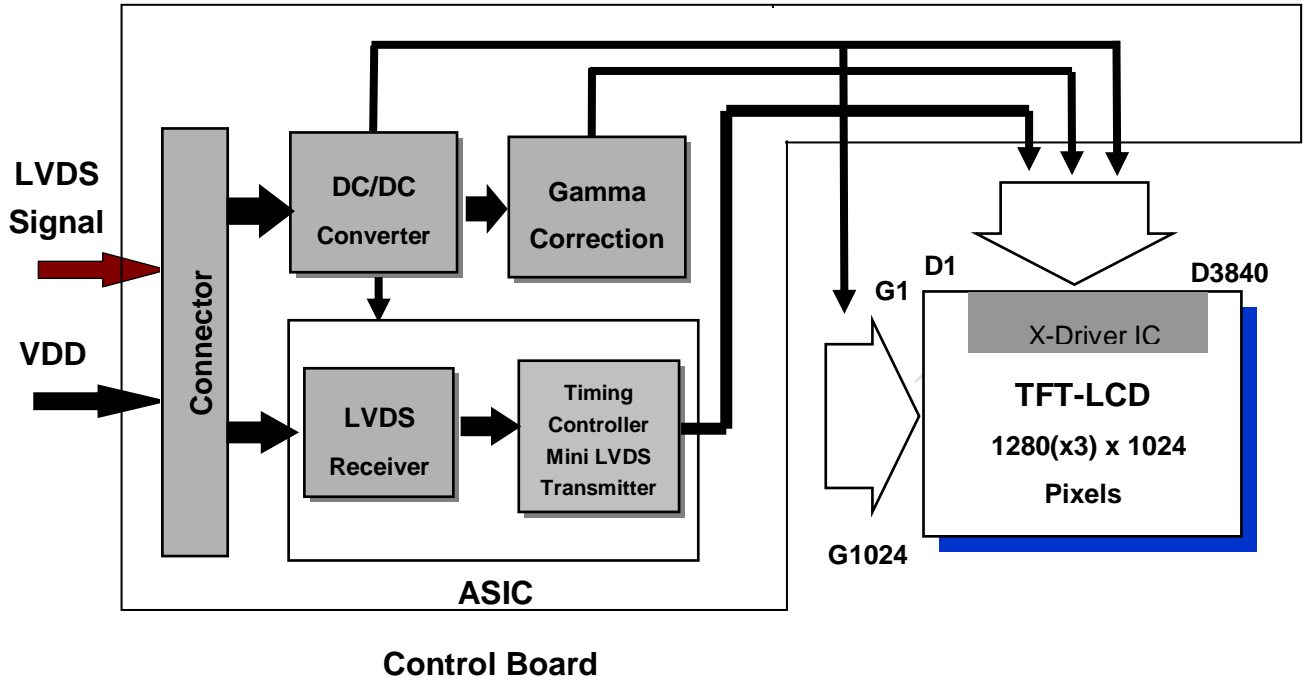

## 3.2 Interface Connection

### 3.2.1 Connector Type

TFT-LCD Connector	Manufacturer	P-TWO	STM
	Part Number	187034-3009	MSBKT2407P30HB
Mating Connector	Manufacturer	JAE or Compatible	
	Part Number	FI-X30HL (Locked Type)	

## 3.2.2 Connector Pin Assignment

PIN #	Symbol	Description	Remark
1	RxOIN0-	Negative LVDS differential data input (Odd data)	
2	RxOIN0+	Positive LVDS differential data input (Odd data)	
3	RxOIN1-	Negative LVDS differential data input (Odd data)	
4	RxOIN1+	Positive LVDS differential data input (Odd data)	
5	RxOIN2-	Negative LVDS differential data input (Odd data)	
6	RxOIN2+	Positive LVDS differential data input (Odd data)	
7	GND	Power Ground	
8	RxOCLKIN-	Negative LVDS differential clock input (Odd clock)	
9	RxOCLKIN+	Positive LVDS differential clock input (Odd clock)	
10	RxOIN3-	Negative LVDS differential data input (Odd data)	
11	RxOIN3+	Positive LVDS differential data input (Odd data)	
12	RxEIN0-	Negative LVDS differential data input (Even data)	
13	RxEIN0+	Positive LVDS differential data input (Even data)	
14	GND	Power Ground	
15	RxEIN1-	Positive LVDS differential data input (Even data)	
16	RxEIN1+	Negative LVDS differential data input (Even data)	
17	GND	Power Ground	
18	RxEIN2-	Negative LVDS differential data input (Even data)	
19	RxEIN2+	Positive LVDS differential data input (Even data)	
20	RxECLKIN-	Negative LVDS differential clock input (Even clock)	
21	RxECLKIN+	Positive LVDS differential clock input (Even clock)	
22	RxEIN3-	Negative LVDS differential data input (Even data)	
23	RxEIN3+	Positive LVDS differential data input (Even data)	
24	GND	Power Ground	
25	GND	NC & Power Ground	
26	NC	No connection (for AUO test)	
27	NC	No connection (for AUO test)	
28	POWER	Power +5V	
29	POWER	Power +5V	
30	POWER	Power +5V	

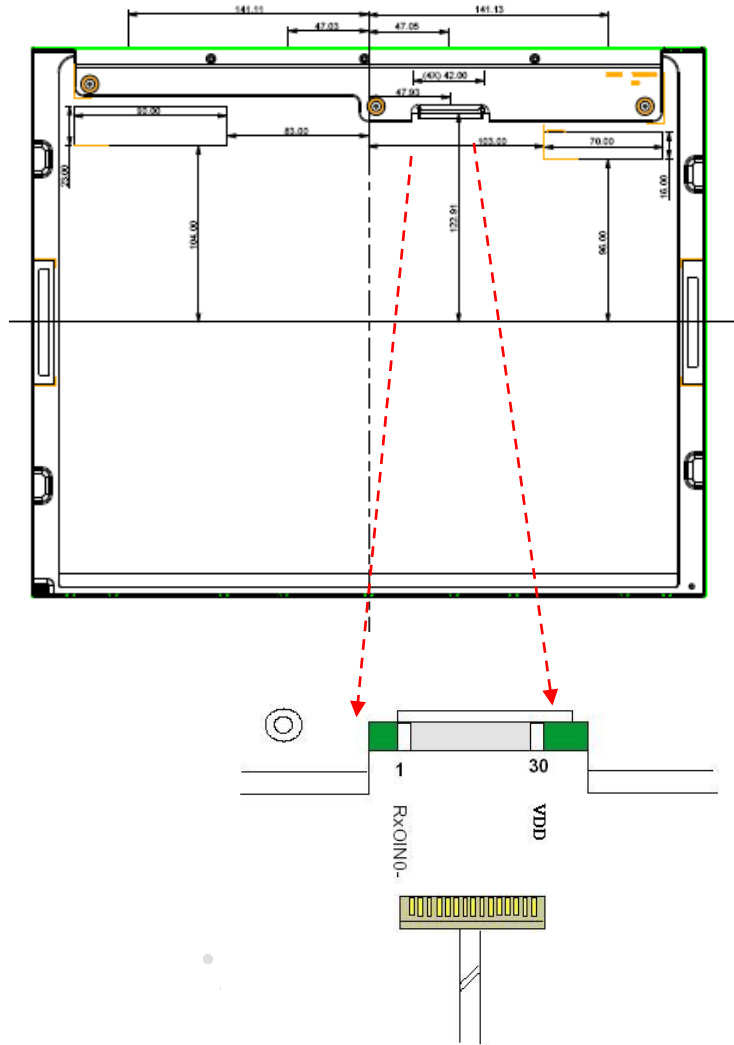

## 3.3 Electrical Characteristics

### 3.3.1 Absolute Maximum Rating

Permanent damage may occur if exceeding the following maximum rating.

Symbol	Description	Min	Max	Unit	Remark
VDD	Power Supply Input Voltage	GND-0.3	6.0	[Volt]	Ta=25°C

### 3.3.2 Recommended Operating Condition

Symbol	Description	Min	Typ	Max	Unit	Remark
VDD	Power supply Input voltage	4.5	5.0	5.5	[Volt]	
IDD	Power supply Input Current (RMS)	-	0.53	0.64	[A]	VDD= 5.0V, Black Pattern, Fv=60Hz
			0.61	0.73	[A]	VDD= 5.0V, Black Pattern, Fv=75Hz
PDD	VDD Power Consumption	-	2.7	3.2	[Watt]	VDD= 5.0V, Black Pattern, Fv=60Hz
			3.05	3.7	[Watt]	VDD= 5.0V, Black Pattern, Fv=75Hz
IRush	Inrush Current	-	-	3.0	[A]	<b>Note 3-1</b>
VDDrp	Allowable VDD Ripple Voltage	-	-	500	[mV]	VDD= 5.0V, Black Pattern, Fv=75Hz

**Note 3-1:** Inrush Current measurement:

Test circuit:

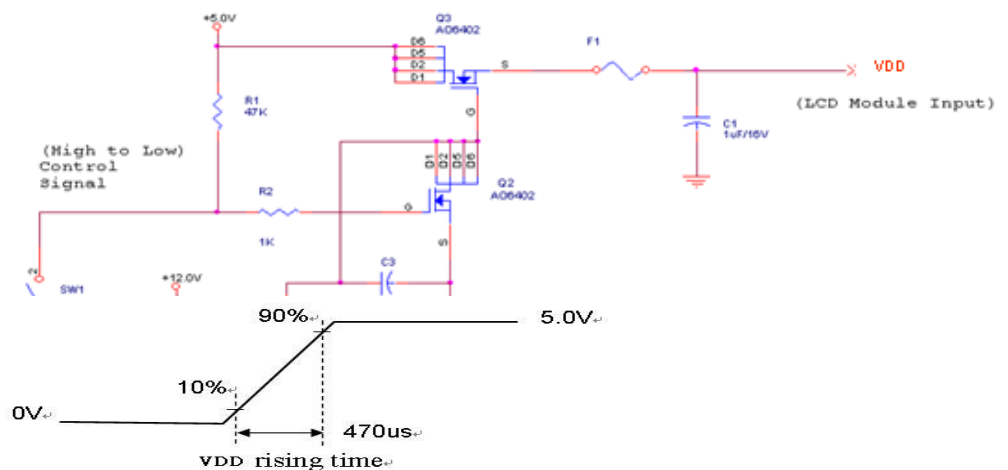

The duration of VDD rising time: 470us.

## 3.4 Signal Characteristics

### 3.4.1 LCD Pixel Format

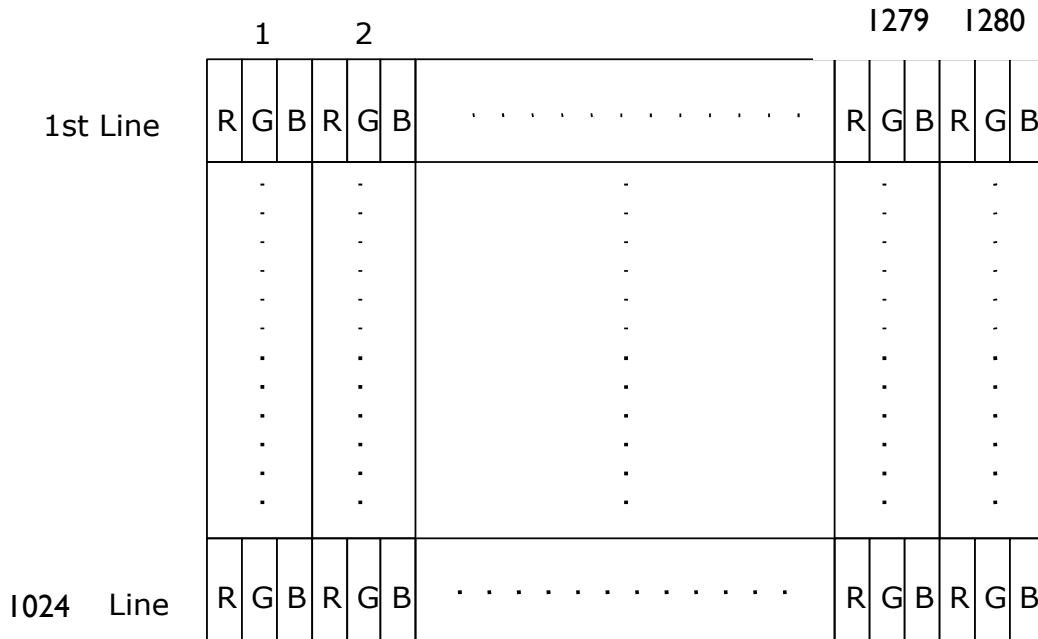

### 3.4.2 LVDS Data Format

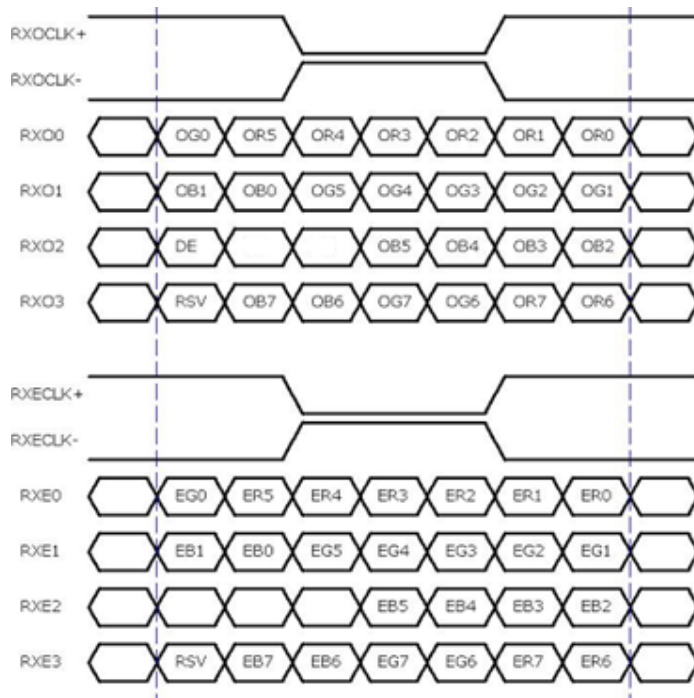

8 Bit Color Bit Order			
<b>MSB</b>	R7	G7	B7
	R6	G6	B6
	R5	G5	B5
	R4	G4	B4
	R3	G3	B3
	R2	G2	B2
	R1	G1	B1
<b>LSB</b>	R0	G0	B0

**Note 3-2:**

- a. O = "Odd Pixel Data"    E = "Even Pixel Data"
- b. Refer to 3.4.1 LCD pixel format, the 1st data is 1 (Odd Pixel Data), the 2<sup>nd</sup> data is 2 (Even Pixel Data) and the last data is 1280 (Even Pixel Data).



### 3.4.3 Color versus Input Data

The following table is for color versus input data (8bit). The higher the gray level, the brighter the color.

Color	Gray Level	Color Input Data																								Remark
		RED data (MSB:R7, LSB:R0)								GREEN data (MSB:G7, LSB:G0)								BLUE data (MSB:B7, LSB:B0)								
		R7	R6	R5	R4	R3	R2	R1	R0	G7	G6	G5	G4	G3	G2	G1	G0	B7	B6	B5	B4	B3	B2	B1	B0	
Black	-	0	0	0	0	0	0	0	0	0	0	0	0	0	0	0	0	0	0	0	0	0	0	0	0	
White	-	1	1	1	1	1	1	1	1	1	1	1	1	1	1	1	1	1	1	1	1	1	1	1	1	
Gray 127	-	0	1	1	1	1	1	1	1	0	1	1	1	1	1	1	1	0	1	1	1	1	1	1	1	
Red	L0	0	0	0	0	0	0	0	0	0	0	0	0	0	0	0	0	0	0	0	0	0	0	0	0	Black
	:	:	:	:	:	:	:	:	:	:	:	:	:	:	:	:	:	:	:	:	:	:	:	:	:	
	L255	1	1	1	1	1	1	1	1	0	0	0	0	0	0	0	0	0	0	0	0	0	0	0	0	
Green	L0	0	0	0	0	0	0	0	0	0	0	0	0	0	0	0	0	0	0	0	0	0	0	0	0	Black
	:	:	:	:	:	:	:	:	:	:	:	:	:	:	:	:	:	:	:	:	:	:	:	:	:	
	L255	0	0	0	0	0	0	0	0	1	1	1	1	1	1	1	1	0	0	0	0	0	0	0	0	
Blue	L0	0	0	0	0	0	0	0	0	0	0	0	0	0	0	0	0	0	0	0	0	0	0	0	0	Black
	:	:	:	:	:	:	:	:	:	:	:	:	:	:	:	:	:	:	:	:	:	:	:	:	:	
	L255	0	0	0	0	0	0	0	0	0	0	0	0	0	0	0	0	1	1	1	1	1	1	1	1	

### 3.4.4 LVDS Specification

#### a. DC Characteristics:

Symbol	Description	Min	Typ	Max	Units	Condition
$V_{TH}$	LVDS Differential Input High Threshold	-	-	+100	[mV]	$V_{CM} = 1.2V$
$V_{TL}$	LVDS Differential Input Low Threshold	-100	-	-	[mV]	$V_{CM} = 1.2V$
$ V_{ID} $	LVDS Differential Input Voltage	100	-	600	[mV]	
$V_{CM}$	LVDS Common Mode Voltage	+1.0	+1.2	+1.5	[V]	$V_{TH} - V_{TL} = 200mV$

#### LVDS Signal Waveform:

Use RxOCLK- & RxOCLK+ as example.

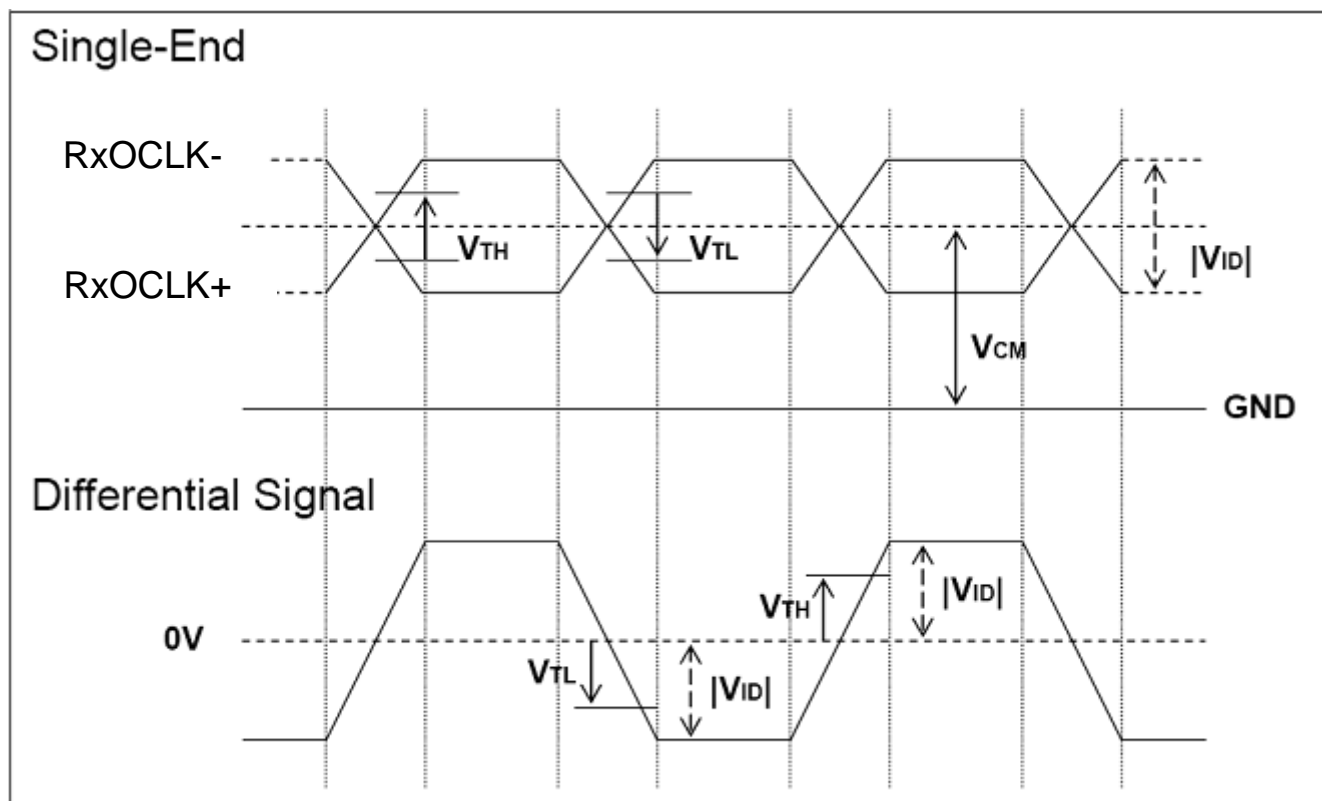

**b. AC Characteristics:**

Symbol	Description	Min	Max	Unit	Remark
$F_{DEV}$	Maximum deviation of input clock frequency during Spread Spectrum	-	$\pm 3$	%	
$F_{MOD}$	Maximum modulation frequency of input clock during Spread Spectrum	-	200	KHz	

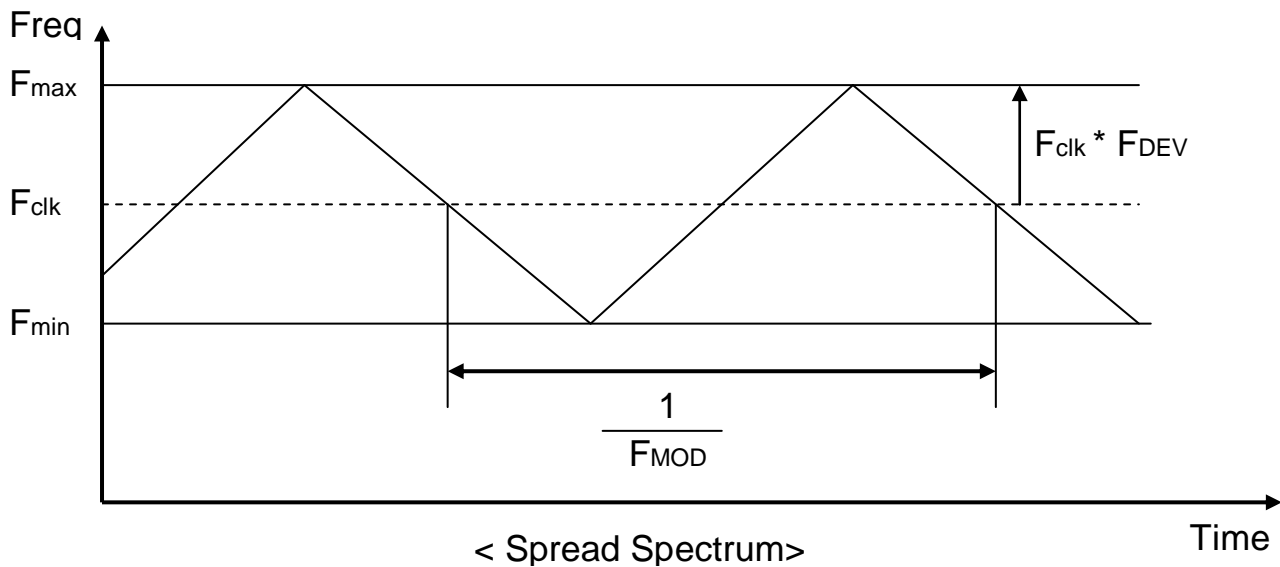

Fclk: LVDS Clock Frequency

### 3.4.5 Input Timing Specification

It only support DE mode, and the input timing are shown as the following table.

Symbol	Description		Min.	Typ.	Max.	Unit	Remark
Tv	Vertical Section	Period	1036	1066	1873	Th	
Tdisp (v)		Active	1024	1024	1024	Th	
Tblk (v)		Blanking	12	42	849	Th	
Fv		Frequency	50	60	76	Hz	<b>Note 3-3</b>
Th	Horizontal Section	Period	730	844	1320	Tclk	
Tdisp (h)		Active	640	640	640	Tclk	
Tblk (h)		Blanking	90	204	680	Tclk	
Fh		Frequency	51.8	64	93.7	KHz	<b>Note 3-4</b>
Tclk	LVDS Clock	Period	14.6	18.5	26.4	ns	1/Fclk
Fclk		Frequency	37.8	54	68.4	MHz	<b>Note 3-5</b>

**Note 3-3:** The optimal Vertical Frequency is 50~76 Hz for best picture quality

**Note 3-4:** The equation is listed as following. Please don't exceed the above recommended value.

$$Fh \text{ (Min.)} = Fclk \text{ (Min.)} / Th \text{ (Min.)};$$

$$Fh \text{ (Typ.)} = Fclk \text{ (Typ.)} / Th \text{ (Typ.)};$$

$$Fh \text{ (Max.)} = Fclk \text{ (Max.)} / Th \text{ (Min.)};$$

**Note 3-5:** The equation is listed as following. Please don't exceed the above recommended value.

$$Fclk \text{ (Min.)} = Fv \text{ (Min.)} \times Th \text{ (Min.)} \times Tv \text{ (Min.)};$$

$$Fclk \text{ (Typ.)} = Fv \text{ (Typ.)} \times Th \text{ (Typ.)} \times Tv \text{ (Typ.)};$$

$$Fclk \text{ (Max.)} = Fv \text{ (Max.)} \times Th \text{ (Typ.)} \times Tv \text{ (Typ.)};$$

## 3.4.6 Input Timing Diagram

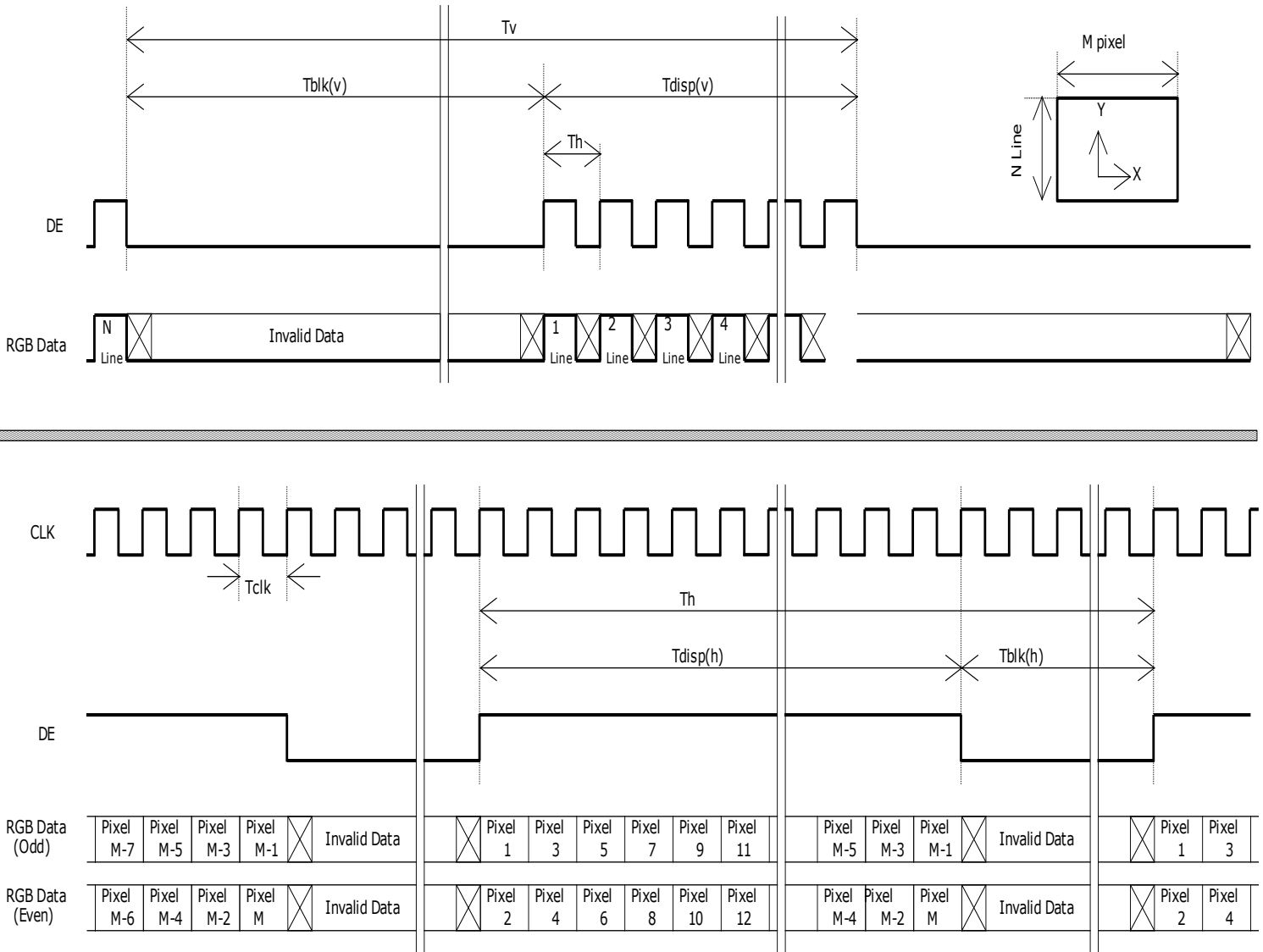

### 3.5 Power ON/OFF Sequence

VDD power, LVDS signal and backlight on/off sequence are as following. LVDS signals from any system shall be Hi-Z state when VDD is off.

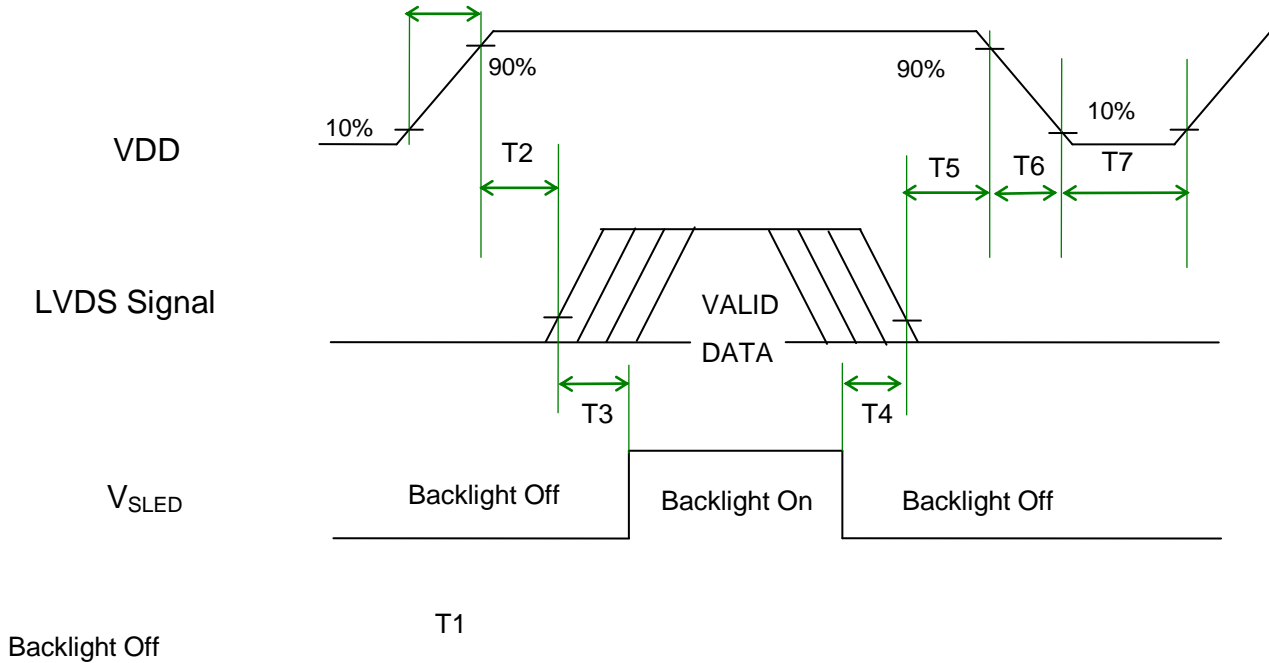

### Power Sequence Timing

Symbol	Value			Unit	Remark
	Min.	Typ.	Max.		
T1	0.5	-	10	[ms]	
T2	0	-	50	[ms]	
T3	500	-	-	[ms]	
T4	100	-	-	[ms]	<b>Note 3-8</b>
T5	0	-	50	[ms]	<b>Note 3-6</b> <b>Note 3-7</b>
T6	0	-	200	[ms]	
T7	1000	-	-	[ms]	

**Note 3-6 :** Recommend setting T5 = 0ms to avoid electronic noise when VDD is off.

**Note 3-7 :** During T5 period , please keep the level of input LVDS signals with Hi-Z state.

**Note 3-8 :** If T4 < 100ms, there will be no reliability concern, but the display may momentarily show abnormal screen.

## 4 Backlight Unit

### 4.1 Block Diagram

The following shows the block diagram of the 19.0 inch Backlight Unit. And it includes 44 pcs LED in the LED light bar. (4 strings and 11 pcs LED of one string).

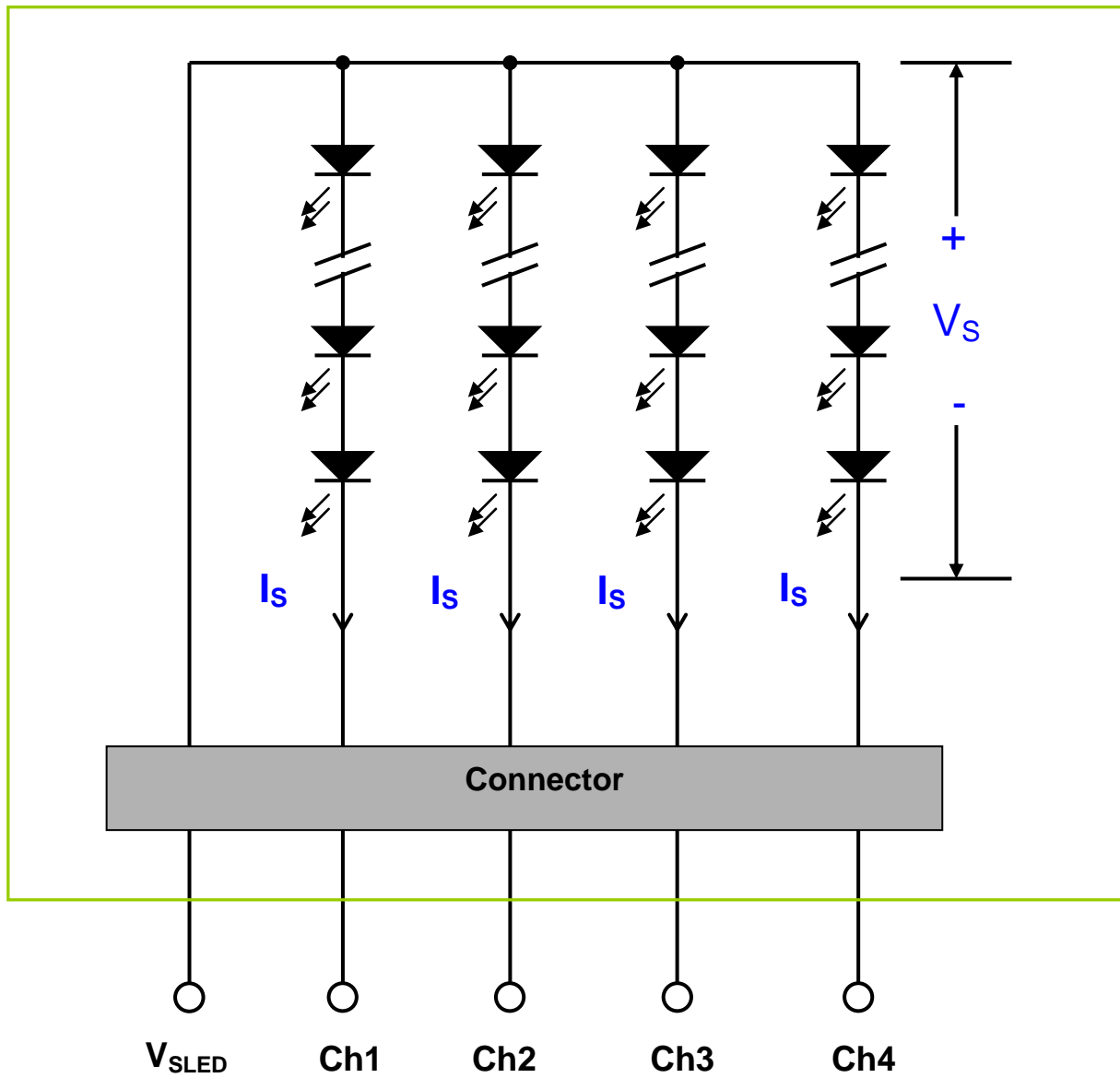

## 4.2 Interface Connection

### 4.2.1 Connector Type

Backlight Connector	Manufacturer	ENTERY
	Part Number	3707K-S06N-21R
Mating Connector	Manufacturer	ENTERY
	Part Number	HI12K-P06N-00B (Non-Locking type) HI12K-P06N-13B (Locking type)

### Backlight Connector dimension:

$H \times V \times D = 13.9 \times 3.00 \times 4.25$ ,  $Pitch = 1.0$ (unit = mm)

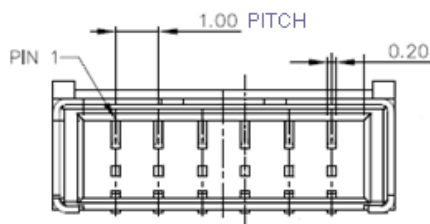
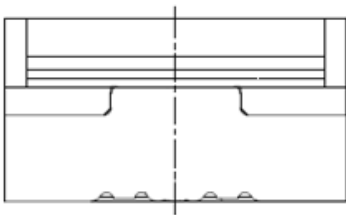



Mating Connector dimension:

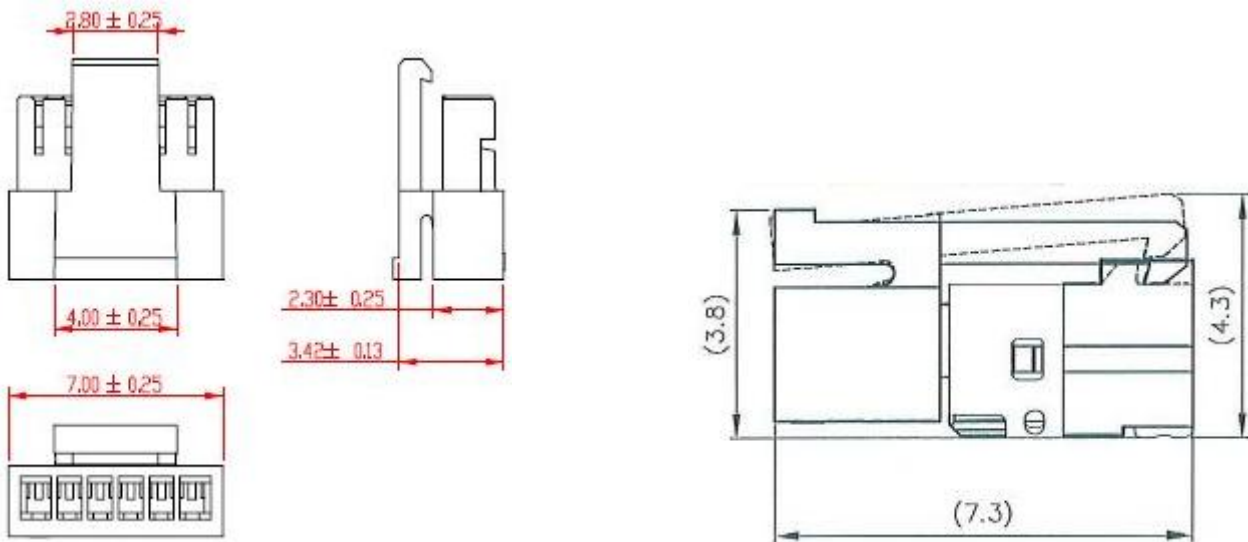

## 4.2.2 Connector Pin Assignment

Pin#	Symbol	Description	Remark
1	Ch1	LED Current Feedback Terminal (Channel 1)	
2	Ch2	LED Current Feedback Terminal (Channel 2)	
3	V <sub>SLED</sub>	LED Power Supply Voltage Input Terminal	
4	V <sub>SLED</sub>	LED Power Supply Voltage Input Terminal	
5	Ch3	LED Current Feedback Terminal (Channel 3)	
6	Ch4	LED Current Feedback Terminal (Channel 4)	

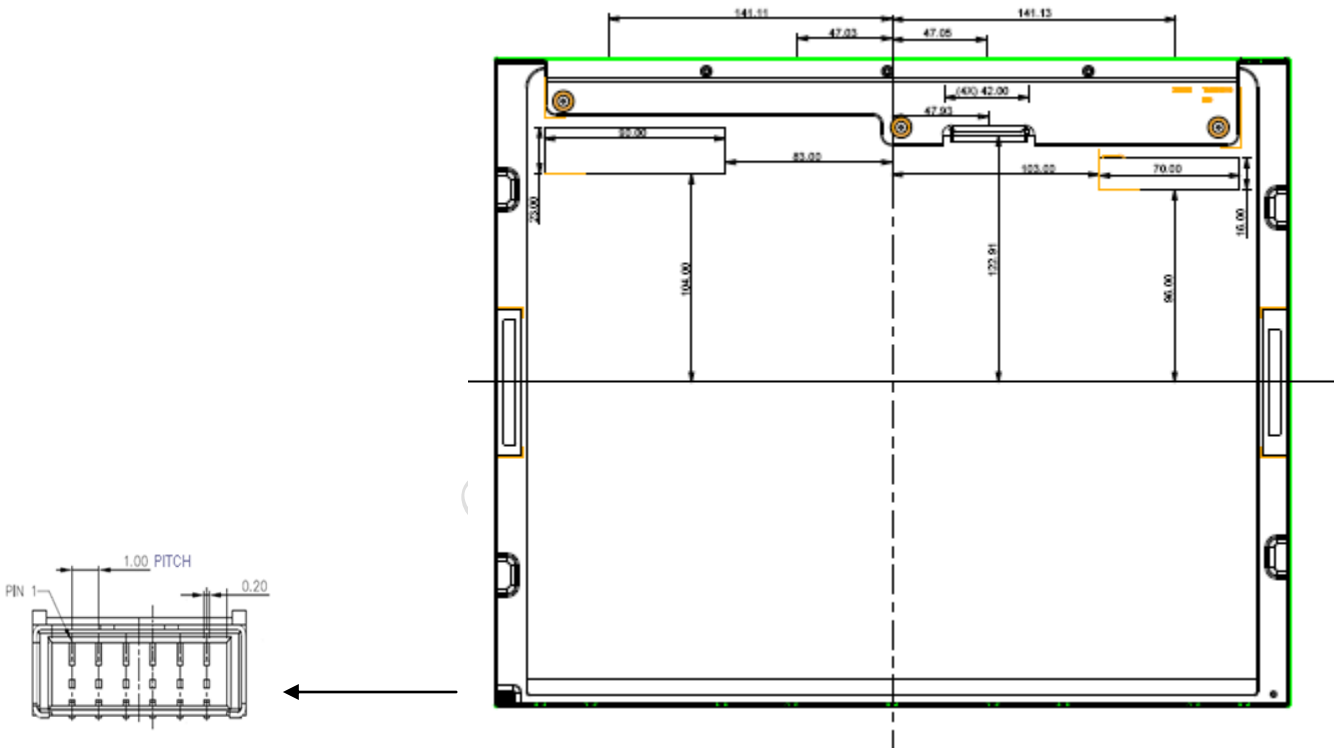

## 4.3 Electrical Characteristics

### 4.3.1 Absolute Maximum Rating

Permanent damage may occur if exceeding the following maximum rating.

(Ta=25°C)

Symbol	Description	Min	Max	Unit	Remark
I <sub>s</sub>	LED String Current	0	90	[mA]	100% duty ratio

### 4.3.2 Recommended Operating Condition

(Ta=25°C)

Symbol	Description	Min.	Typ.	Max.	Unit	Remark
I <sub>s</sub>	LED String Current	-	50	53	[mA]	100% duty ratio of LED chip, <b>Note 4-6</b>
V <sub>s</sub>	LED String Voltage	27.2	30.5	33.7	[Volt]	I <sub>s</sub> =50mA @ 100% duty ratio; <b>Note 4-1, Note 4-5, Note 4-7</b>
ΔV <sub>s</sub>	Maximum V <sub>s</sub> Voltage Deviation of light bar	-	-	2.2	[Volt]	I <sub>s</sub> =50mA @ 100% duty ratio; <b>Note 4-2</b>
P <sub>BLU</sub>	LED Light Bar Power Consumption	-	6.1	6.74	[Watt]	<b>Note 4-3</b>
LT <sub>LED</sub>	LED Life Time	30,000	-	-	[Hour]	<b>Note 4-4</b>
OVP	Over Voltage Protection in system board	110% V <sub>s</sub> (max)	-	-	[Volt]	<b>Note 4-5</b>

**Note 4-1:**  $V_s (\text{Typ.}) = V_F (\text{Typ.}) \times \text{LED No. (one string)}$ ;

- a.  $V_F$ : LED chip forward voltage,  $V_F (\text{Min.})=2.47\text{V}$ ,  $V_F(\text{Typ.})=2.77 \text{ V}$ ,  $V_F(\text{Max.})=3.06\text{V}$
- b. The same equation to calculate  $V_s(\text{Min.})$  &  $V_s (\text{Max.})$  for respective  $V_F (\text{Min.})$  &  $V_F(\text{Max.})$ ;

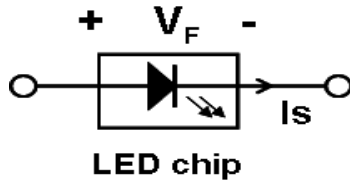

**Note 4-2:**  $\Delta V_s (\text{Max.}) = \Delta V_F \times \text{LED No. (one string)}$ ;

- a.  $\Delta V_F$ : LED chip forward voltage deviation; (0.2V , each Bin of LED  $V_F$ )

**Note 4-3:**  $P_{\text{BLU}} (\text{Typ.}) = V_s (\text{Typ.}) \times I_s (\text{Typ.}) \times 4$  ; ( 4 is total String No. of LED Light bar)

$$P_{\text{BLU}} (\text{Max.}) = V_s (\text{Max.}) \times I_s (\text{Typ.}) \times 4 ;$$

**Note 4-4:** Definition of life time:

- a. Brightness of LED becomes to 50% of its original value
- b. Test condition:  $I_s = 50\text{mA}$  and  $25^\circ\text{C}$  (Room Temperature)

**Note 4-5:** Recommendation for LED driver power design:

Due to there are electrical property deviation in LED & monitor set system component after long time operation. AUO strongly recommend the design value of LED driver board OVP (over voltage protection) should be 10% higher than max. value of LED string voltage ( $V_s$ ) at least.

**Note 4-6:** AUO strongly recommend “Analog Dimming” method for backlight brightness control for Wavy Noise Free. Otherwise, recommend that Dimming Control Signal (PWM Signal) should be synchronized with Frame Frequency.

**Note 4-7:** Ensure that the LED light bar is not subjected either forward or reverse voltage while monitor set is on standby mode or not in use.



5 Reliability Test

AUO reliability test items are listed as following table. (*Bare Panel only*)

Items	Condition	Remark
Temperature Humidity Bias (THB)	Ta= 50°C , 80%RH, 300hours	
High Temperature Operation (HTO)	Ta= 50°C , 50%RH, 300hours	
Low Temperature Operation (LTO)	Ta= 0°C , 300hours	
High Temperature Storage (HTS)	Ta= 60°C , 300hours	
Low Temperature Storage (LTS)	Ta= -20°C , 300hours	
Vibration Test (Non-operation)	Acceleration: 1.5 Grms Wave: Random Frequency: 10 - 200 Hz Sweep: 30 Minutes each Axis (X, Y, Z)	
Shock Test (Non-operation)	Acceleration: 50 G Wave: Half-sine Active Time: 20 ms Direction: ±X, ±Y, ±Z (one time for each Axis)	
Drop Test	Height: 46 cm, package test	
Thermal Shock Test (TST)	-20°C/30min, 60°C/30min, 100 cycles	<b>Note 5-1</b>
On/Off Test	On/10sec, Off/10sec, 30,000 cycles	
ESD (Electro Static Discharge)	Contact Discharge: ± 15KV, 150pF(330Ω ) 1sec, 8 points, 25 times/ point.	<b>Note 5-2</b>
	Air Discharge: ± 15KV, 150pF(330Ω ) 1sec 8 points, 25 times/ point.	
Altitude Test	Operation:18,000 ft Non-Operation:40,000 ft	

**Note 5-1:** a. A cycle of rapid temperature change consists of varying the temperature from -20°C to 60°C, and back again. Power is not applied during the test.  
 b. After finish temperature cycling, the unit is placed in normal room ambient for at least 4 hours before power on.

**Note 5-2:** EN61000-4-2, ESD class B: Certain performance degradation allowed  
 No data lost  
 Self-recoverable  
 No hardware failures.

ESD discharged points should avoid display area and periphery front bezel of display area. Suggest points were 4 side parallel edge of display area surface.

Metal front bezel must cover half area of BM (black matrix), and metal front

bezel must connect with metal back bezel to protect source IC of panel by ESD damaged.

**Note 5-3:** Result Evaluation Criteria:

TFT-LCD panels test should take place after gradually cooling enough at room temperature  
 In the normal application, there should be no particular problems that may affect the display function.

## 6 Shipping Label

The label is on the panel as shown below:

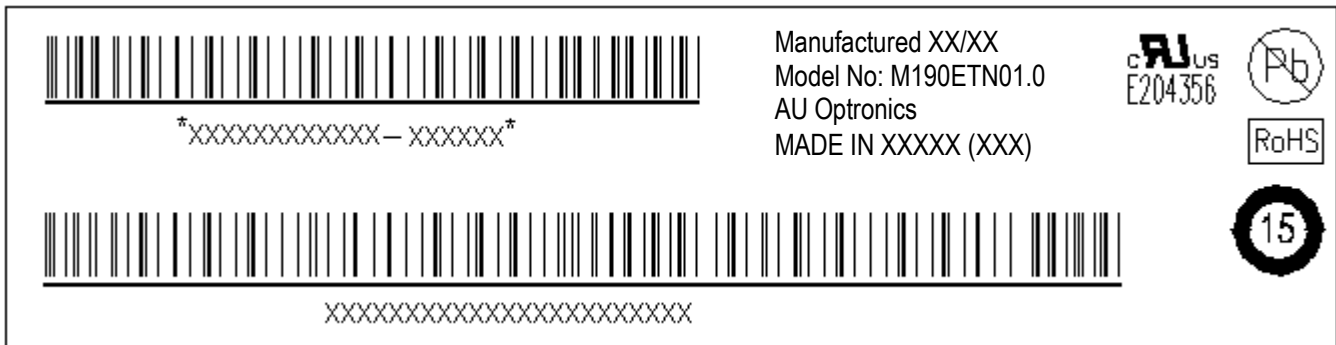

**Note 6-1:** For Pb Free products, AUO will add  for identification.

**Note 6-2:** For RoHS compatible products, AUO will add  for identification.

**Note 6-3:** For China RoHS compatible products, AUO will add  for identification.

**Note 6-4:** The Green Mark will be presented only when the green documents have been ready by AUO Internal Green Team.

# 7 Mechanical Characteristics

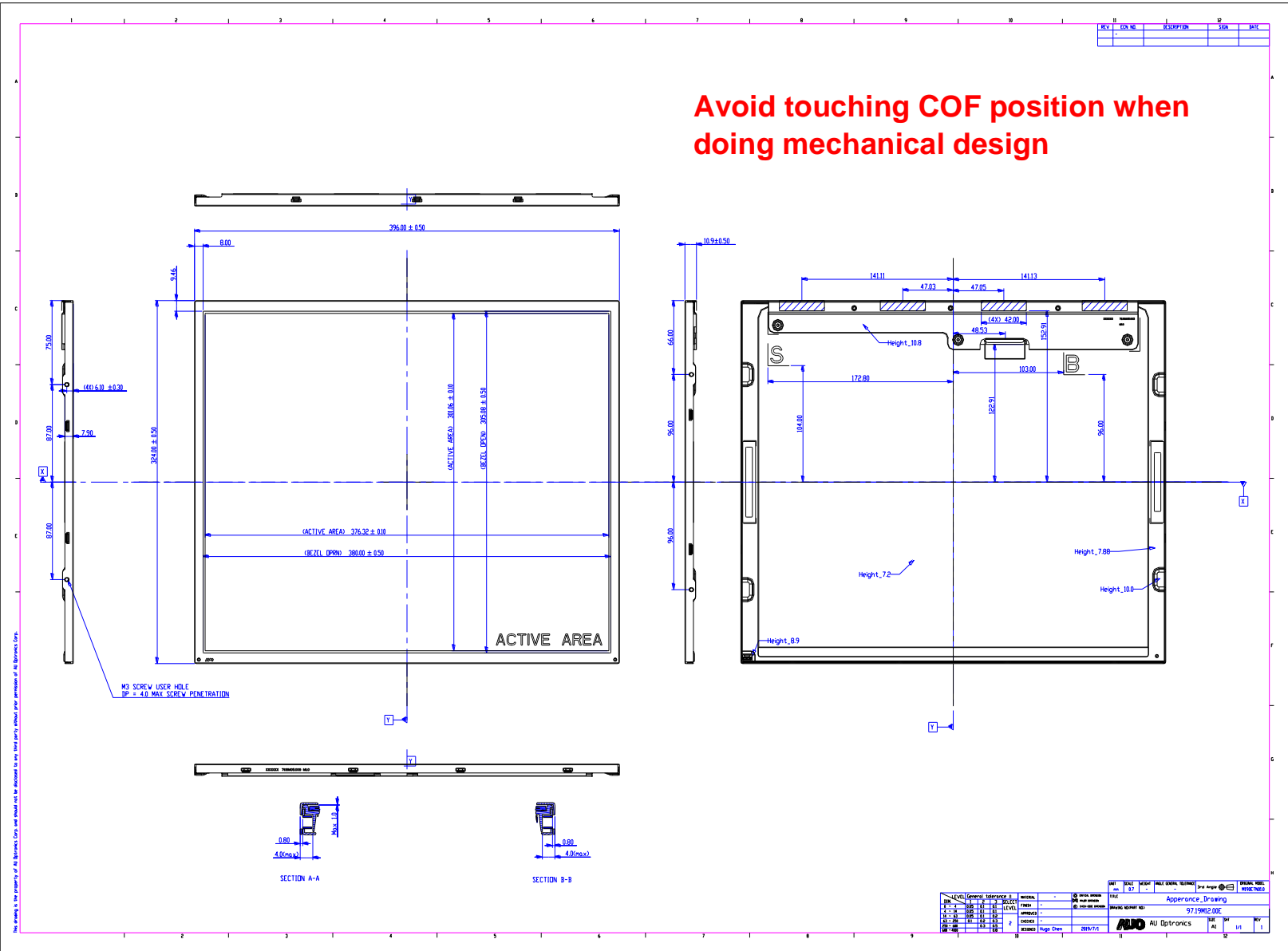

# 8 Packing Specification

## 8.1 Packing Flow

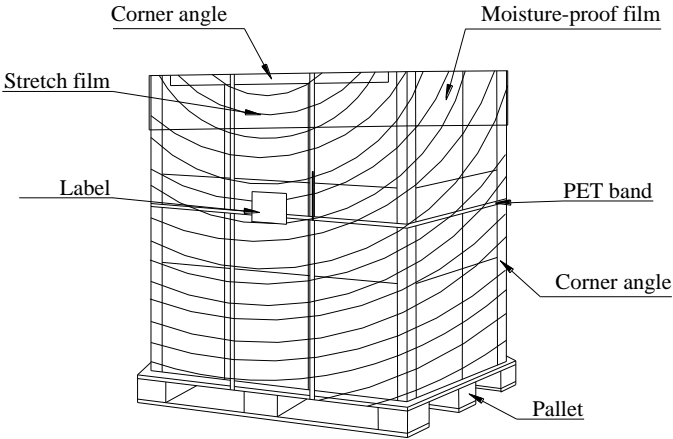
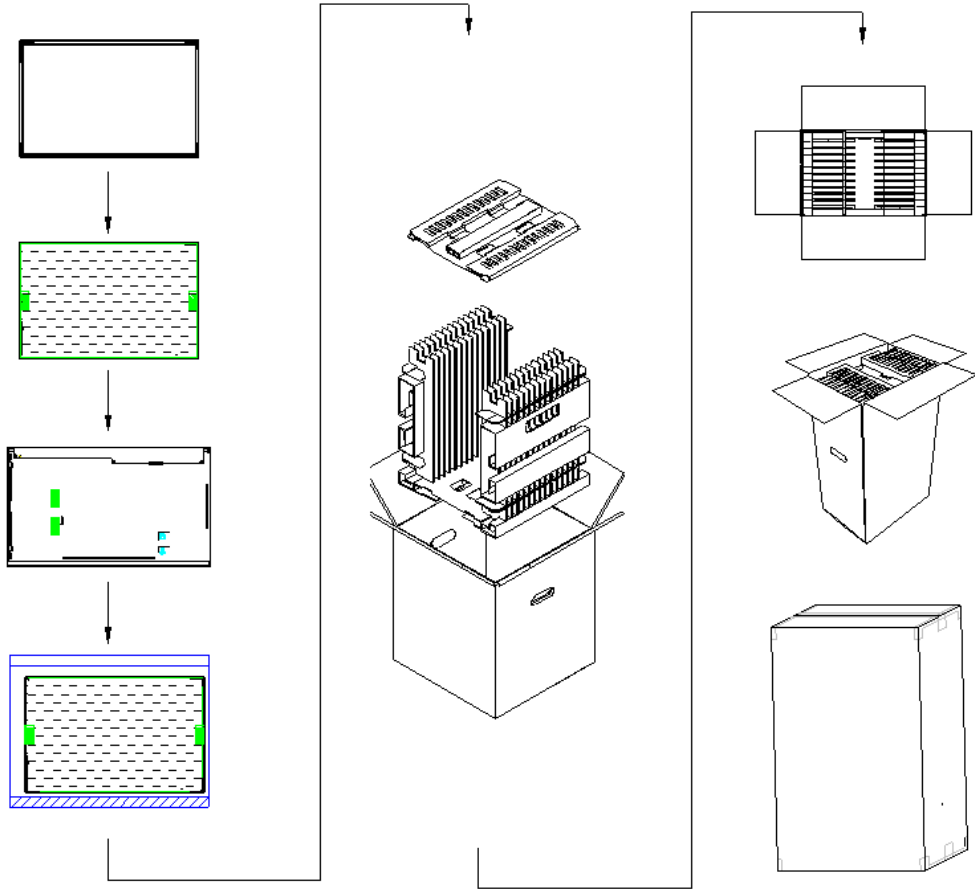



## 8.2 Pallet and shipment information

Item	Specification			Remark
	Q'ty	Dimension	Weight(kg)	
Panel	1	396(H)mm x 324(V)mm x 10.9(D)mm	1.8	<i>Note 1</i>
Cushion	1	--	1.85	
Box	1	409(L)mm x 367(W)mm x 475(H)mm	1.44	without Panel & cushion <i>Note 1</i>
Packing Box	13 pcs/Box	409(L)mm x 367(W)mm x 475(H)mm	26.83	with panel & cushion <i>Note 1</i>
Pallet	1	1150(L)mm x 840(W)mm x 132(H)mm	12	<i>Note 1</i>
Pallet after Packing	18 boxes/pallet	1150(L)mm x 840(W)mm x 156.5(H)mm	492.42	<i>Note 1</i>

**Note 1:** Estimated value which is subject to change based on real measured data.