

TITLE : MV190E0M-N10**Product Specification****Rev.O****BEIJING BOE Display TECHNOLOGY**

BOE	PRODUCT GROUP	REV	ISSUE DATE
	TFT- LCD PRODUCT	Rev. O	May. 3, 16'

REVISION HISTORY

() preliminary specification

(●) Final specification

Revision No.	Page	Description of changes	Date	Prepared
Rev.P0		Preliminary Specification	Oct.30.2015	Lu Kun
Rev.P1	9	Add R/G/B coordinate	Jan.12.2016	Lu Kun
	11	LED connector type changed	Jan.12.2016	Lu Kun
	29	Module outline (rear view) change d	Jan.12.2016	Lu Kun
Rev.P2	14	Signal timing specification updated	May.3.2016	Lu Kun
	25	box label updated	May.3.2016	Lu Kun
Rev. O		Preliminary Specification	May.3.2016	Lu Kun

Contents

No.	Item	Page
1.0	General Description	4
2.0	Absolute Maximum Ratings	6
3.0	Electrical Specifications	7
4.0	Optical Specifications	9
5.0	Interface Connection	11
6.0	Signal Timing Specifications	14
7.0	Signal Timing Waveforms of Interface Signal	16
8.0	Input Signals, Display Colors & Gray Scale of Colors	18
9.0	Power Sequence	19
10.0	Mechanical Characteristics	20
11.0	Reliability Test	21
12.0	Handling & Cautions	22
13.0	Product Serial Number	23
14.0	Packing	24
15.0	Appendix	26

1.0 GENERAL DESCRIPTION

1.1 Introduction

MV190E0M-N10 is a color active matrix TFT LCD module using amorphous silicon TFT's (Thin Film Transistors) as an active switching devices. This module has a 19 inch diagonally measured active area with SXGA resolutions (1280 horizontal by 1024 vertical pixel array). Each pixel is divided into RED, GREEN, BLUE dots which are arranged in vertical stripe and this module can display 16.7M colors. The TFT-LCD panel used for this module is adapted for a low reflection and higher color type.

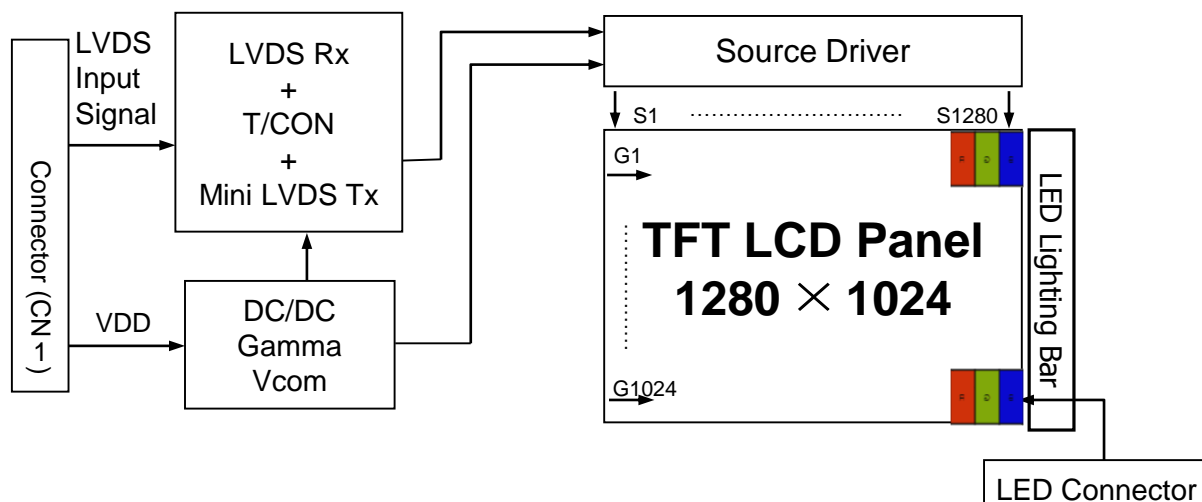

1.2 Features

- LVDS Interface with 2 pixel / clock
- High-speed response
- 6-bit (Hi-FRC) color depth, display 16. 7M colors
- Incorporated edge type back-light (LED)
- NTSC 72%
- High luminance and contrast ratio, low reflection and wide viewing angle
- DE (Data Enable) only
- RoHS/Halogen Free
- E/S 7.0 compliant
- Gamma Correction

1.3 Application

- Desktop Type of PC & Workstation Use
- Slim-Size Display for Stand-alone Monitor
- Display Terminals for Control System
- Monitors for Process Controller

1.4 General Specification

The followings are general specifications at the model MV190E0M-N10.

<Table 1. General Specifications>

Parameter	Specification	Unit	Remarks
Active area	374.784(H) x 299.8272(V)	mm	
Number of pixels	1280(H) × 1024(V)	pixels	
Pixel pitch	0.0976(H) x 0.2928(V)	mm	
Pixel arrangement	RGB Vertical stripe		
Display colors	16.7M	colors	
Display mode	Normally Black		
Dimensional outline	396.0(H) × 324.0(V) × 9.9(D) typ.	mm	Detail refer to drawing
Weight	1690 (Typ.)	g	
Bezel width (L/R/U/D)	8.6/8.6/10.5/10.5	mm	
Surface Treatment	Haze 25%, 3H		
Back-light	Right edge side, 1-LED Lighting Bar type		

2.0 ABSOLUTE MAXIMUM RATINGS

The followings are maximum values which, if exceed, may cause faulty operation or damage to the unit. The operational and non-operational maximum voltage and current values are listed in Table 2.

< Table 2. Absolute Maximum Ratings >

[VSS=GND=0V]

Parameter	Symbol	Min.	Max.	Unit	Remarks
Power Supply Voltage	V_{DD}	-0.3	6.0	V	Ta = 25 °C
Logic Supply Voltage	V_{IN}	VSS-0.3	$V_{DD}+0.3$	V	
Operating Temperature	T_{OP}	0	+50	°C	1)
Storage Temperature	T_{ST}	-20	+60	°C	1)
Panel Surface Temperature (Operation)	Tsurface	0	+65	°C	2)

Note : 1) Temperature and relative humidity range are shown in the figure below.

Wet bulb temperature should be 39 °C max. and no condensation of water.

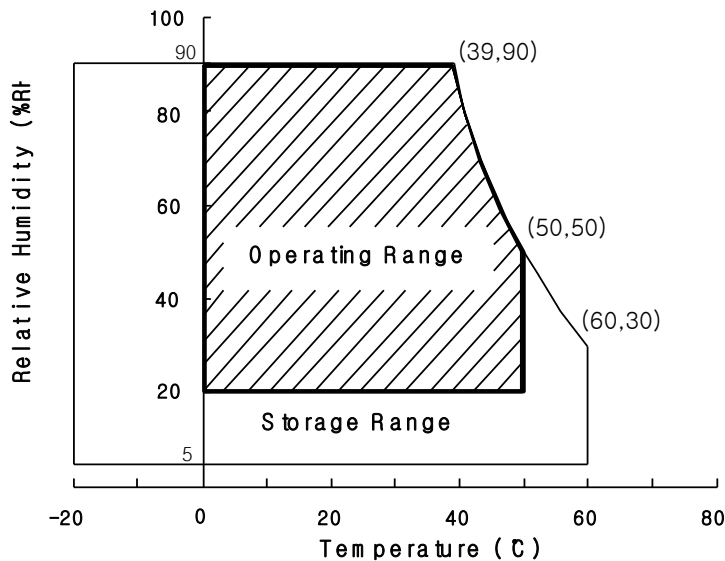

Note : 2) Panel Surface Temperature should be Min. 0°C and Max. +65°C under the VDD = 5.0V, Frame rate = 60Hz, 25°C ambient Temp. no humidity control and LED string current is typical value.

3.0 ELECTRICAL SPECIFICATIONS

3.1 Electrical Specifications

< Table 3. Electrical specifications >

[Ta =25 ± 2 °C]

Parameter		Min.	Typ.	Max.	Unit	Remarks
Power Supply Voltage	V _{DD}	4.5	5.0	5.5	V	Note 1
Power Supply Current	I _{DD}	-	600	1100	mA	
In-Rush Current	I _{RUSH}	-	2.0	3.0	A	Note 2
Permissible Input Ripple Voltage	V _{RF}	-	-	300	mV	Note 4
High Level Differential Input Threshold Voltage	V _{IH}	-	-	+100	mV	
Low Level Differential Input Threshold Voltage	V _{IL}	-100	-	-	mV	
Differential input voltage	V _{ID}	200	-	600	mV	
Differential input common mode voltage	V _{cm}	1.0	1.2	1.5		V _{IH} =100mV, V _{IL} =-100mV
Power Consumption	P _D	-	3	5.5	W	
	P _{BL}	-	8.55	9.12	W	Note 3
	P _{total}	-	11.55	14.62	W	

- Notes : 1. The supply voltage is measured and specified at the interface connector of LCM.
 The current draw and power consumption specified is for VDD=5.0V, Frame rate=75Hz
 Clock frequency = 92.89 MHz. Test Pattern of power supply current
 a) Typ : Color Test
 b) Max : Vertical Subline255

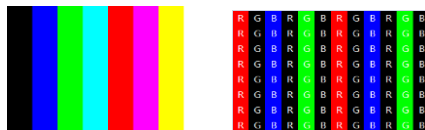

- Notes : 2. Duration of rush current is about 2 ms and rising time of VDD is 520 μs ± 20 %
 Notes : 3. Calculated value for reference (Input pins*VPIN × IPIN) excluding inverter loss.
 Notes : 4. Permissible Input ripple Voltage should be measured under V_{DD} =5.0V, 25° C, fV(frame frequency)=MAX condition(@ Gray level 255 Gray level 0) and At that time, we recommend the bandwidth configuration of oscilloscope is to be under 20Mhz. Ripple Voltage should be covered by Input voltage Spec.

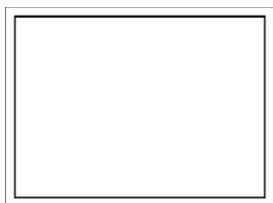

Gray level 255



Gray level 0

3.2 Backlight Unit

< Table 4. LED Backlight Unit >

Parameter		Min.	Typ.	Max.	Unit	Remarks
LED Light Bar Input Voltage Per Input Pin	VPIN	42	45	48	V	Duty 100%
LED Light Bar Input Current Per Input Pin	IPIN	-	95	-	mA	Note1,2
LED Power Consumption	P _{BL}	-	8.55	9.12	W	Note 3
LED Life-Time	-	30,000	-		Hrs	Note 4

LED bar consists of 30LED packages, 2 strings(parallel)*15packages(serial)

Note1: There are one light bar ,and the specified current is input LED chip 100% duty current

Note2: The sense current of each input pin is 95mA

Note3: $P_{BL}=2\text{Input pins} \times \text{VPIN} \times \text{IPIN}$

Note4: The lifetime is determined as the time at which luminance of LED become 50% of the initial brightness or not normal lighting at IPIN=95mA on condition of continuous operating at $25 \pm 2 \text{ } ^\circ\text{C}$

4.0 OPTICAL SPECIFICATION

4.1 Overview

The test of Optical specifications shall be measured in a dark room (ambient luminance ≤ 1 lux and temperature = $25 \pm 2^\circ\text{C}$) with the equipment of Luminance meter system (Goniometer system and TOPCONE BM-5) and test unit shall be located at an approximate distance 50cm from the LCD surface at a viewing angle of θ and Φ equal to 0° . We refer to $\theta_{\theta=0}$ ($=\theta_3$) as the 3 o'clock direction (the "right"), $\theta_{\theta=90}$ ($=\theta_{12}$) as the 12 o'clock direction ("upward"), $\theta_{\theta=180}$ ($=\theta_9$) as the 9 o'clock direction ("left") and $\theta_{\theta=270}$ ($=\theta_6$) as the 6 o'clock direction ("bottom"). While scanning θ and/or Φ , the center of the measuring spot on the Display surface shall stay fixed. The measurement shall be executed after 30 minutes warm-up period. VDD shall be 5.0V +/-10% at 25°C . Optimum viewing angle direction is 6 'clock.

4.2 Optical Specifications

[VDD = 5.0V, Frame rate = 60Hz, Clock = 74.25MHz, $I_{BL} = 190\text{mA}$, $T_a = 25 \pm 2^\circ\text{C}$]

< Table 5. Module Optical >

Parameter		Symbol	Condition	Min.	Typ.	Max.	Unit	Remark
Viewing Angle range	Horizontal	Θ_3	CR > 10	85	89	-	Deg.	Note 1
		Θ_9		85	89	-	Deg.	
	Vertical	Θ_{12}		85	89	-	Deg.	
		Θ_6		85	89	-	Deg.	
Luminance Contrast ratio		CR	$\Theta = 0^\circ$ (Center) Normal Viewing Angle	700	1000	-		Note 2
Luminance of White		Y_w		200	250	-	cd/m ²	Note 3
White luminance uniformity		ΔY		75	-	-	%	Note 4
Reproduction of color	White	W_x		0.283	0.313	0.343	-	Note 5
		W_y		0.299	0.329	0.359	-	
	Red	R_x		0.605	0.635	0.665	-	
		R_y		0.320	0.350	0.380	-	
	Green	G_x	0.295	0.325	0.355	-		
		G_y	0.599	0.629	0.659	-		
Blue	B_x	0.121	0.151	0.181	-			
	B_y	0.016	0.046	0.076	-			
Response Time	GTG	T_g	-	14	20	ms	Note 6	
	Rising	T_r	-	8	11	ms		
	Falling	T_f	-	8	11	ms		
Cross Talk		CT	-	-	2.0	%	Note 7	

Note :

- Viewing angle is the angle at which the contrast ratio is greater than 10. The viewing are determined for the horizontal or 3, 9 o'clock direction and the vertical or 6, 12 o'clock direction with respect to the optical axis which is normal to the LCD surface.
- Contrast measurements shall be made at viewing angle of $\theta = 0^\circ$ and at the center of the LCD surface. Luminance shall be measured with all pixels in the view field set first to white, then to the dark (black) state. (See FIGURE 1 shown in Appendix) Luminance Contrast Ratio (CR) is defined mathematically.

$$CR = \frac{\text{Luminance when displaying a white raster}}{\text{Luminance when displaying a black raster}}$$

- Center Luminance of white is defined as the LCD surface. Luminance shall be measured with all pixels in the view field set first to white. This measurement shall be taken at the locations shown in FIGURE 2 for a total of the measurements per display.
- The White luminance uniformity on LCD surface is then expressed as :
 $\Delta Y = (\text{Minimum Luminance of 9points} / \text{Maximum Luminance of 9points}) * 100$
 (See FIGURE 2 shown in Appendix).
- The color chromaticity coordinates specified in Table 5. shall be calculated from the spectral data measured with all pixels first in red, green, blue and white. Measurements shall be made at the center of the panel.
- Response time T_g is the average time required for display transition by switching the input signal as below table and is based on Frame rate $f_V = 60\text{Hz}$ to optimize. Each time in below table is defined as FIGURE 3 shown in Appendix and shall be measured by switching the signal for "any level of gray(bright)" and "any level of gray(dark)". Response time T_r shall be measured by switching the signal from " 0 level of gray" to "255 level of gray" in FIGURE 3 shown in Appendix. And response time T_f shall be measured by switching the signal from " 255 level of gray" to "0 level of gray" in FIGURE 3 shown in Appendix.

Measured Response Time	Target																
	0	15	31	47	63	79	95	111	127	143	159	175	191	207	223	239	255
0																	
15																	
31																	
47																	
63																	
79																	
95																	
111																	
127																	
143																	
159																	
175																	
191																	
207																	
223																	
239																	
255																	

- Cross-Talk of one area of the LCD surface by another shall be measured by comparing the luminance (Y_A) of a 25mm diameter area, with all display pixels set to a gray level, to the luminance (Y_B) of that same area when any adjacent area is driven dark. (See FIGURE 4 shown in Appendix).

5.0 INTERFACE CONNECTION.

5.1 Electrical Interface Connection

5.1.1 LED Light Bar

< Table 6. LED Light Bar >

Pin No	Symbol	Description
1	IRLED1	LED current sense for string1
2	NC	No Connection
3	VLED	LED power supply
4	VLED	LED power supply
5	NC	No Connection
6	IRLED2	LED current sense for string2
7	CONNECTOR	SM06B-SHJH(HF)

Remark: The mating type connector: SHJP-06V-S(HF) or SHJP-06-A-K(HF) and equivalent

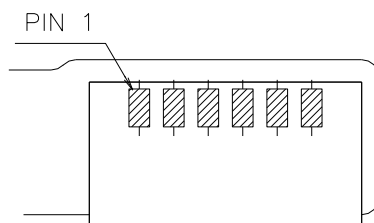

Figure1. Top View of LED Bar Connector

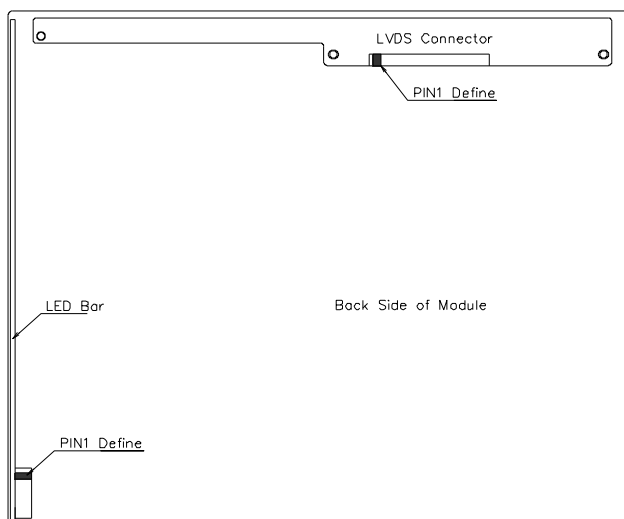

Figure2. Back Side of Module

5.0 INTERFACE CONNECTION.

5.1 Electrical Interface Connection

- CN11 Module Side Connector : UJU IS100-L30R-C23or Equivalent
User Side Connector : JAE FI-X30H or Equivalent

Pin No	Symbol	Function	Remark
1	RX00-	Negative Transmission data of Pixel 0 (ODD)	
2	RX00+	Positive Transmission data of Pixel 0 (ODD)	
3	RX01-	Negative Transmission data of Pixel 1 (ODD)	
4	RX01+	Positive Transmission data of Pixel 1 (ODD)	
5	RX02-	Negative Transmission data of Pixel 2 (ODD)	
6	RX02+	Positive Transmission data of Pixel 2 (ODD)	
7	GND	Power Ground	
8	RXOC-	Negative Transmission Clock (ODD)	
9	RXOC+	Positive Transmission Clock (ODD)	
10	RX03-	Negative Transmission data of Pixel 3 (ODD)	
11	RX03+	Positive Transmission data of Pixel 3 (ODD)	
12	RXE0-	Negative Transmission data of Pixel 0 (EVEN)	
13	RXE0+	Positive Transmission data of Pixel 0 (EVEN)	
14	GND	Power Ground	
15	RXE1-	Negative Transmission data of Pixel 1 (EVEN)	
16	RXE1+	Positive Transmission data of Pixel 1 (EVEN)	
17	GNG	Power Ground	
18	RXE2-	Negative Transmission data of Pixel 2 (EVEN)	
19	RXE2+	Positive Transmission data of Pixel 2 (EVEN)	
20	RXEC-	Negative Transmission Clock (EVEN)	
21	RXEC+	Positive Transmission Clock (EVEN)	
22	RXE3-	Negative Transmission data of Pixel 3 (EVEN)	
23	RXE3+	Positive Transmission data of Pixel 3 (EVEN)	
24	GND	Power Ground	Note 1
25	NC	No. Connection	
26	NC	No. Connection	
27	NC	No. Connection	
28	VDD	Power Supply: +5V	
29	VDD		
30	VDD		

Note 1 : This pin should be connected with GND.

5.2 LVDS Interface (Tx; THC63LVDF83A or Equivalent)

5.2.1 LVDS Interface

	Input Signal	Transmitter		Interface		MV190E0M-N10 (CN11)	Remark						
		Pin No.	Pin No.	System (Tx)	TFT-LCD (Rx)	Pin No.							
LVDS	OR0	51	48 47	OUT0- OUT0+	RX00- RX00+	1							
	OR1	52						2					
	OR2	54				46 45			OUT1- OUT1+	RX01- RX01+	3		
	OR3	55						4					
	OR4	56									42 41	OUT2- OUT2+	RX02- RX02+
	OR5	3						6					
	OG0	4	38 37	OUT3- OUT3+	RX03- RX03+	10							
	OG1	6						11					
	OG2	7				18							
	OG3	11						25					
	OG4	12				8							
	OG5	14						9					
	OB0	15				10							
	OB1	19						11					
	OB2	20	16										
	OB3	22		18									
	OB4	23	25										
	OB5	24		8									
	Hsync	27	9										
	Vsync	28		10									
DE	30	11											
MCLK	31		40 39	CLK OUT- CLK OUT+	RXO CLK- RXO CLK+	8 9							
OR6	50	2											
OR7	2		8										
OG6	8	10											
OG7	10		11										
OB6	16	18											
OB7	18		25										
RSVD	25	8											
			9										

Note: The order of even data is same with odd data.

6.0 SIGNAL TIMING SPECIFICATION

6.1 The MV190E0M-N10 is operated by the DE only.

Item	Symbols		Min	Typ	Max	Unit	Note
DCLK	Period	tCLK	14.81	18.52	22.22	ns	
	Frequency	-	40	54	67.5	MHz	
Hsync	Period	tHP	704	844	960	tCLK	
	Horizontal Valid	tHV	640	640	640	tCLK	
	Horizontal Blank	tHB	64	204	320	tCLK	
	Frequency	fH	53.3	63.96	80	KHz	
Vsync	Period	tVP	1036	1066	1150	tHP	
	Vertical Valid	tVV	1024	1024	1024	tHP	
	Vertical Blank	tVB	12	42	72	tHP	
	Frequency	fV	50	60	75	Hz	
LVDS Receiver clock	Input spread spectrum ratio	SSr	-3	-	+3	%	

Note : The DCLK range at last line of V-blanking should be set in 0-H-active/2

6.2 LVDS Rx Interface Timing Parameter

The specification of the LVDS Rx interface timing parameter is shown in Table 4.

<Table 7. LVDS Rx Interface Timing Specification>

Item	Symbol	Min	Typ	Max	Unit	Remark
CLKIN Period	tRCIP	14.81	18.52	22.22	nsec	
Input Data 0	tRIP1	-0.4	0.0	+0.4	nsec	
Input Data 1	tRIP0	tRCIP/7-0.4	tRCIP/7	tRCIP/7+0.4	nsec	
Input Data 2	tRIP6	2 × tRCIP/7-0.4	2 × tRCIP/7	2 × tRCIP/7+0.4	nsec	
Input Data 3	tRIP5	3 × tRCIP/7-0.4	3 × tRCIP/7	3 × tRCIP/7+0.4	nsec	
Input Data 4	tRIP4	4 × tRCIP/7-0.4	4 × tRCIP/7	4 × tRCIP/7+0.4	nsec	
Input Data 5	tRIP3	5 × tRCIP/7-0.4	5 × tRCIP/7	5 × tRCIP/7+0.4	nsec	
Input Data 6	tRIP2	6 × tRCIP/7-0.4	6 × tRCIP/7	6 × tRCIP/7+0.4	nsec	

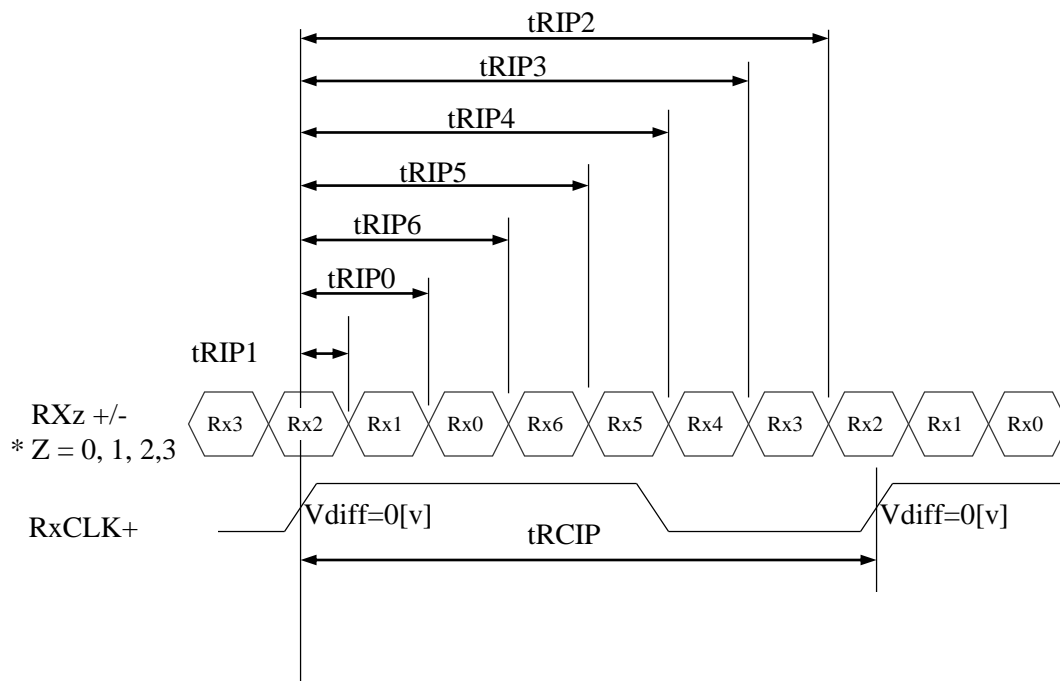

* Vdiff = (RXz+)-(RXz-),.... ,(RXCLK+)-(RXCLK-)

7.0 SIGNAL TIMING WAVEFORMS OF INTERFACE SIGNAL

7.1 Sync Timing Waveforms

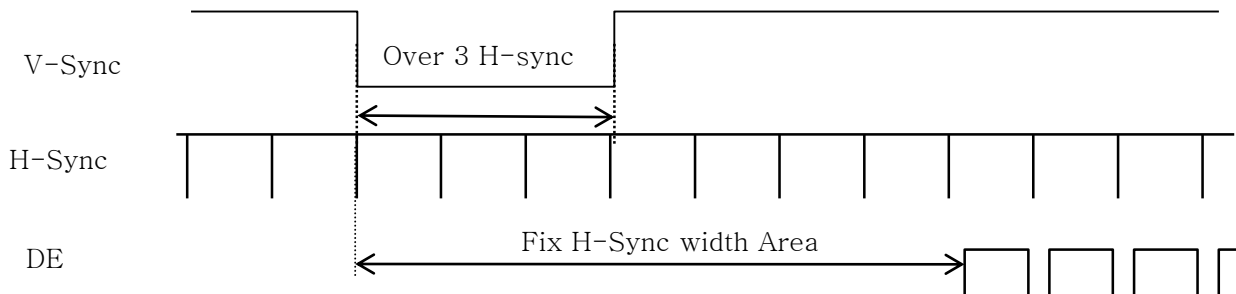

- 1) Need over 3 H-sync during V-Sync Low
- 2) Fix H-Sync width from V-Sync falling edge to first rising edge

7.2 Vertical Timing Waveforms

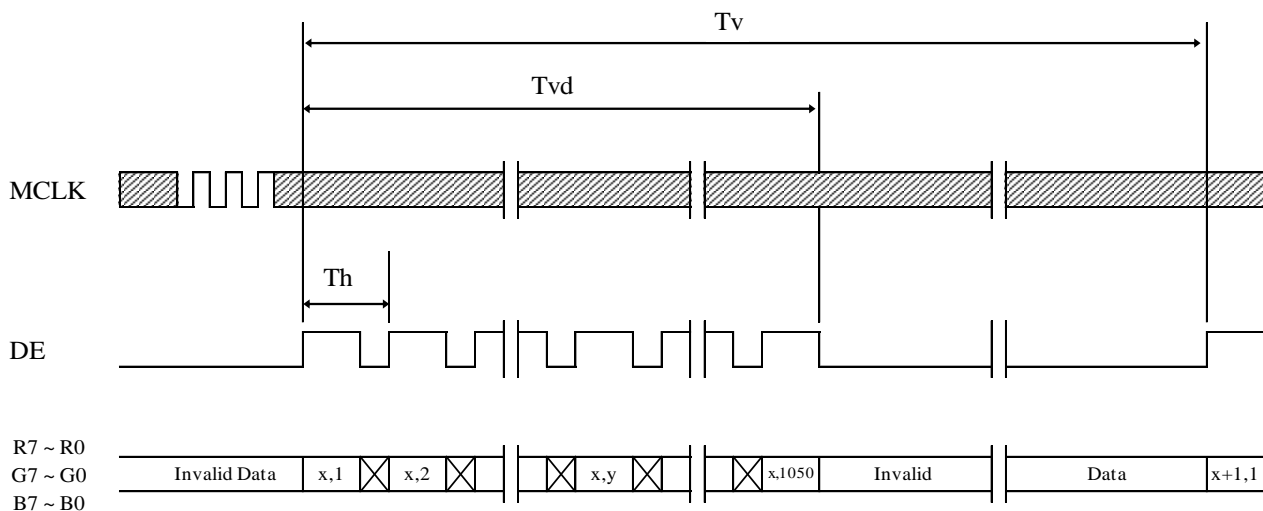

7.3 Horizontal Timing Waveforms

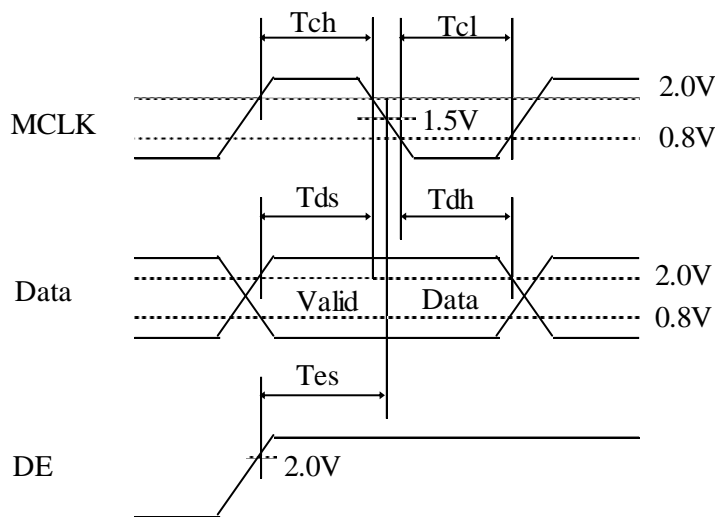
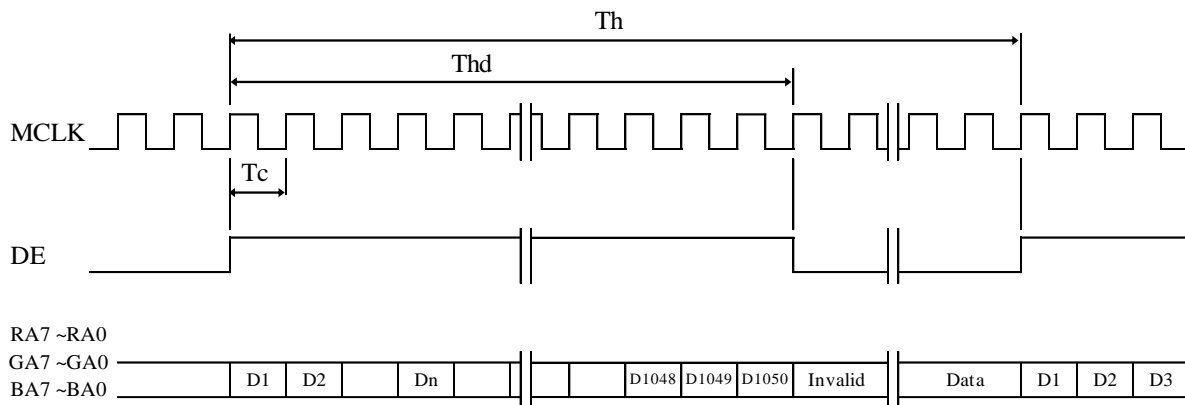

8.0 INPUT SIGNALS, BASIC DISPLAY COLORS & GRAY SCALE OF COLORS

Color & Gray Scale		RED DATA								GREEN DATA								BLUE DATA							
		R7	R6	R5	R4	R3	R2	R1	R0	G7	G6	G5	G4	G3	G2	G1	G0	B7	B6	B5	B4	B3	B2	B1	B0
Basic Colors	Black	0	0	0	0	0	0	0	0	0	0	0	0	0	0	0	0	0	0	0	0	0	0	0	0
	Blue	0	0	0	0	0	0	0	0	0	0	0	0	0	0	0	0	1	1	1	1	1	1	1	1
	Green	0	0	0	0	0	0	0	0	1	1	1	1	1	1	1	1	0	0	0	0	0	0	0	0
	Cyan	0	0	0	0	0	0	0	0	1	1	1	1	1	1	1	1	1	1	1	1	1	1	1	1
	Red	1	1	1	1	1	1	1	1	0	0	0	0	0	0	0	0	0	0	0	0	0	0	0	0
	Magenta	1	1	1	1	1	1	1	1	0	0	0	0	0	0	0	0	1	1	1	1	1	1	1	1
	Yellow	1	1	1	1	1	1	1	1	1	1	1	1	1	1	1	1	0	0	0	0	0	0	0	0
	White	1	1	1	1	1	1	1	1	1	1	1	1	1	1	1	1	1	1	1	1	1	1	1	1
Gray Scale of RED	Black	0	0	0	0	0	0	0	0	0	0	0	0	0	0	0	0	0	0	0	0	0	0	0	0
	△	0	0	0	0	0	0	0	1	0	0	0	0	0	0	0	0	0	0	0	0	0	0	0	0
	Darker	0	0	0	0	0	0	1	0	0	0	0	0	0	0	0	0	0	0	0	0	0	0	0	0
	△	↑								↑								↑							
	▽	↓								↓								↓							
	Brighter	1	1	1	1	1	1	0	1	0	0	0	0	0	0	0	0	0	0	0	0	0	0	0	0
	▽	1	1	1	1	1	1	1	0	0	0	0	0	0	0	0	0	0	0	0	0	0	0	0	0
	Red	1	1	1	1	1	1	1	1	0	0	0	0	0	0	0	0	0	0	0	0	0	0	0	0
Gray Scale of GREEN	Black	0	0	0	0	0	0	0	0	0	0	0	0	0	0	0	0	0	0	0	0	0	0	0	0
	△	0	0	0	0	0	0	0	0	0	0	0	0	0	0	0	1	0	0	0	0	0	0	0	0
	Darker	0	0	0	0	0	0	0	0	0	0	0	0	0	0	1	0	0	0	0	0	0	0	0	0
	△	↑								↑								↑							
	▽	↓								↓								↓							
	Brighter	0	0	0	0	0	0	0	0	1	1	1	1	1	1	0	1	0	0	0	0	0	0	0	0
	▽	0	0	0	0	0	0	0	0	1	1	1	1	1	1	1	0	0	0	0	0	0	0	0	0
	Green	0	0	0	0	0	0	0	0	1	1	1	1	1	1	1	1	0	0	0	0	0	0	0	0
Gray Scale of BLUE	Black	0	0	0	0	0	0	0	0	0	0	0	0	0	0	0	0	0	0	0	0	0	0	0	0
	△	0	0	0	0	0	0	0	0	0	0	0	0	0	0	0	0	0	0	0	0	0	0	0	1
	Darker	0	0	0	0	0	0	0	0	0	0	0	0	0	0	0	0	0	0	0	0	0	0	1	0
	△	↑								↑								↑							
	▽	↓								↓								↓							
	Brighter	0	0	0	0	0	0	0	0	0	0	0	0	0	0	0	0	1	1	1	1	1	1	0	1
	▽	0	0	0	0	0	0	0	0	0	0	0	0	0	0	0	0	1	1	1	1	1	1	1	0
	Blue	0	0	0	0	0	0	0	0	0	0	0	0	0	0	0	0	1	1	1	1	1	1	1	1
Gray Scale of WHITE	Black	0	0	0	0	0	0	0	0	0	0	0	0	0	0	0	0	0	0	0	0	0	0	0	0
	△	0	0	0	0	0	0	0	1	0	0	0	0	0	0	0	1	0	0	0	0	0	0	0	1
	Darker	0	0	0	0	0	0	1	0	0	0	0	0	0	0	1	0	0	0	0	0	0	0	1	0
	△	↑								↑								↑							
	▽	↓								↓								↓							
	Brighter	1	1	1	1	1	1	0	1	1	1	1	1	1	1	0	1	1	1	1	1	1	1	0	1
	▽	1	1	1	1	1	1	1	0	1	1	1	1	1	1	1	0	1	1	1	1	1	1	1	0
	White	1	1	1	1	1	1	1	1	1	1	1	1	1	1	1	1	1	1	1	1	1	1	1	1

9.0 POWER SEQUENCE

To prevent a latch-up or DC operation of the LCD module, the power on/off sequence shall be as shown in below

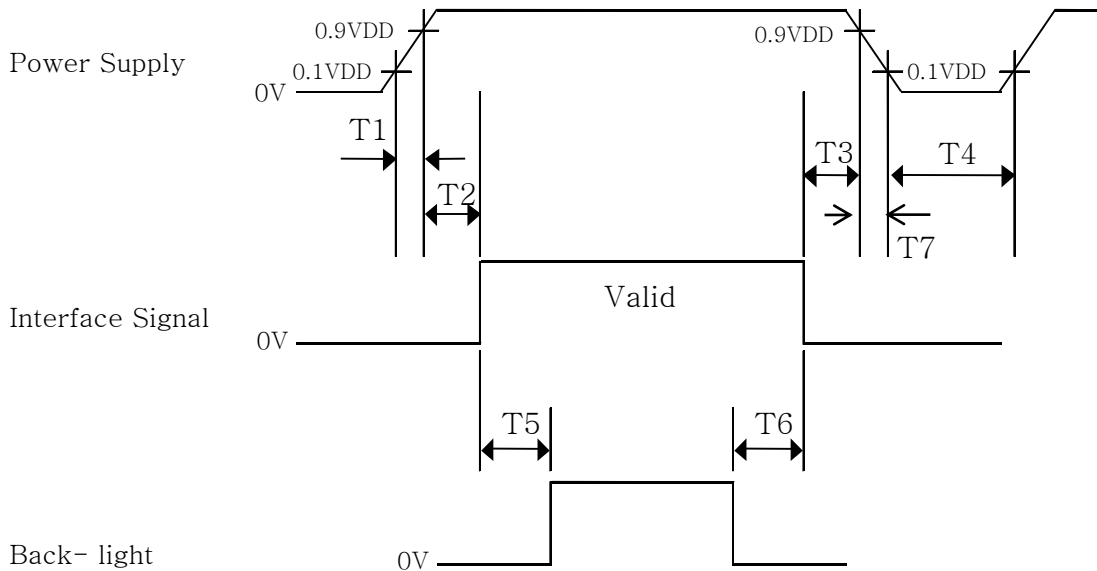

- $0.5 \text{ ms} \leq T1 \leq 10 \text{ ms}$
- $0 \leq T2 \leq 50 \text{ ms}$
- $0 \leq T3 \leq 50 \text{ ms}$
- $1 \text{ sec} \leq T4$
- $200 \text{ ms} \leq T5$
- $200 \text{ ms} \leq T6$

Notes:

1. When the power supply VDD is 0V, keep the level of input signals on the low or keep high impedance.
2. Do not keep the interface signal high impedance when power is on.
3. Back Light must be turn on after power for logic and interface signal are valid.
4. T7 decreases smoothly, there is none re-bouncing voltage.

10.0 MECHANICAL CHARACTERISTICS

10.1 Dimensional Requirements

FIGURE 6 (located in Appendix) shows mechanical outlines for the model MV190E0M-N10. Other parameters are shown in Table 5.

<Table 8. Dimensional Parameters>

Parameter	Specification	Unit
Dimensional outline	396.0(H) × 324.0(V) × 9.9(D) typ.	mm
Weight	1720(typ)	gram
Active area	374.784(H) × 299.8272(V)	mm
Pixel pitch	0.0976(H) × 0.2928(V)	mm
Number of pixels	1280 (H) × 1024 (V) (1 pixel = R + G + B dots)	pixels
Back-light	Right edge side, 1-LED Lighting Bar type	

10.2 Mounting

See FIGURE 5. (shown in Appendix)

10.3 Anti-Glare and Polarizer Hardness.

The surface of the LCD has an anti-glare coating to minimize reflection and a coating to reduce scratching.

10.4 Light Leakage

There shall not be visible light from the back-lighting system around the edges of the screen as seen from a distance 50cm from the screen with an overhead light level of 350lux.

11.0 RELIABILITY TEST

The Reliability test items and its conditions are shown in below.

<Table 9. Reliability Test Parameters >

No	Test Items	Conditions
1	High temperature storage test	Ta = 60 °C, 240 hrs
2	Low temperature storage test	Ta = -20 °C, 240 hrs
3	High temperature & high humidity operation test	Ta = 50 °C, 80%RH, 240hrs
4	High temperature operation test	Ta = 50 °C, 240hrs
5	Low temperature operation test	Ta = 0°C, 240hrs
6	Thermal shock	Ta = -20 °C ↔ 60 °C (0.5 hr), 100 cycle
7	Vibration test (non-operating)	Frequency Random, 10 ~ 300 Hz, 30 min/Axis Gravity / AMP 1.5 Grms Period X, Y, Z 30 min
8	Shock test (non-operating)	Gravity 50G
		Pulse width 11msec, sine wave
		Direction ± X, ± Y, ± Z Once for each
9	Electro-static discharge test (operating)	Air : 150 pF, 330Ω, 15 KV Contact : 150 pF, 330Ω, 8 KV

12.0 HANDLING & CAUTIONS

- (1) Cautions when taking out the module
 - Pick the pouch only, when taking out module from a shipping package.
- (2) Cautions for handling the module
 - As the electrostatic discharges may break the LCD module, handle the LCD module with care. Peel a protection sheet off from the LCD panel surface as slowly as possible.
 - As the LCD panel and back - light element are made from fragile glass material, impulse and pressure to the LCD module should be avoided.
 - As the surface of the polarizer is very soft and easily scratched, use a soft dry cloth without chemicals for cleaning.
 - Do not pull the interface connector in or out while the LCD module is operating.
 - Put the module display side down on a flat horizontal plane.
 - Handle connectors and cables with care.
- (3) Cautions for the operation
 - When the module is operating, do not lose CLK, ENAB signals. If any one of these signals is lost, the LCD panel would be damaged.
 - Obey the supply voltage sequence. If wrong sequence is applied, the module would be damaged.
- (4) Cautions for the atmosphere
 - Dew drop atmosphere should be avoided.
 - Do not store and/or operate the LCD module in a high temperature and/or humidity atmosphere. Storage in an electro-conductive polymer packing pouch and under relatively low temperature atmosphere is recommended.
- (5) Cautions for the module characteristics
 - Do not apply fixed pattern data signal to the LCD module at product aging.
 - Applying fixed pattern for a long time may cause image sticking.
- (6) Other cautions
 - Do not disassemble and/or re-assemble LCD module.
 - Do not re-adjust variable resistor or switch etc.
 - When returning the module for repair or etc., Please pack the module not to be broken. We recommend to use the original shipping packages.

BOE

PRODUCT GROUP

REV

ISSUE DATE

TFT- LCD PRODUCT

Rev. 0

May. 3, 16'

13.0 PRODUCT SERIAL NUMBER

DP/N	MV190E0M-N10	B4	   MADE IN CHINA
XXXXXX			
XXXX	XXXXXXXXXXXXXXXXXXXXXX	REV XXX	
			
XX-XXXXXX-XXXXX-XXX-XXXX			



1. Control Number

2. Rank / Grade

3. Line Classification

4. Year (2001 : 01, 2002 : 02, ...)

5. Month (1,2,3, ... , 9, X, Y, Z)

6. Internal Use

7. Serial Number

SPEC. NUMBER
S

SPEC. TITLE
MV190E0M-N10 Product Specification Rev. 0

PAGE
23 OF 29

14.0 Packing

14.1 Packing Order

Put pad into the box

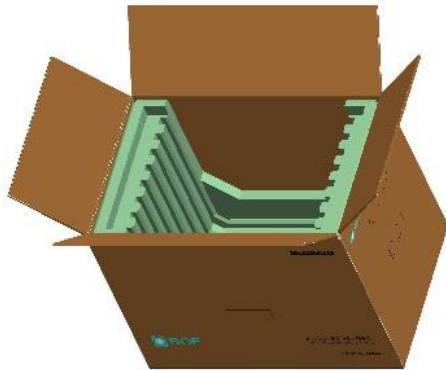

Place the modules bundled by packing bag in the box, 8pcs module per box, place a cover on the top of the box

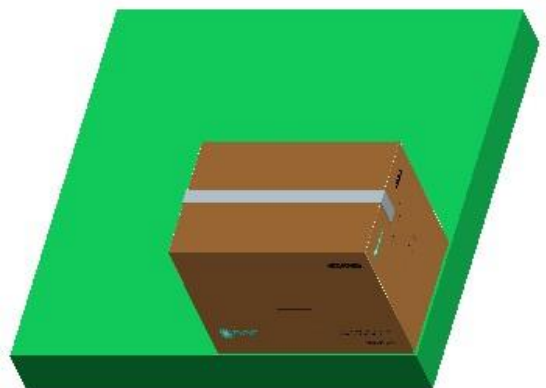
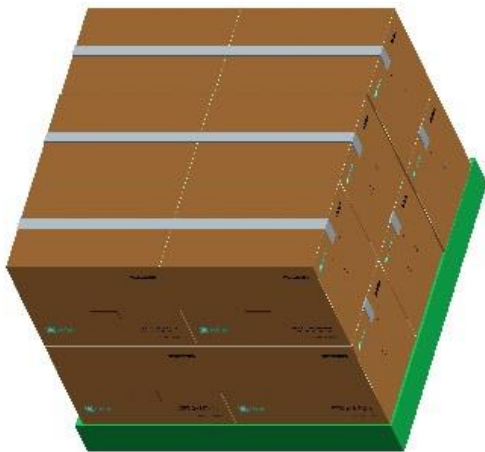
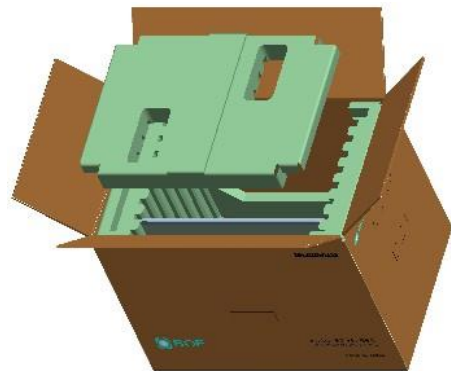

12ea box per pallet

After sealing the box, put the box on the pallet

14.2 Packing Note

- Box Dimension : 521mm * 346mm * 403mm
- Package Quantity in one Box : 8 pcs

14.3 Box label

- Label Size : 108 mm (L) × 56 mm (W)
- Contents
Model : MV190E0M-N10
Q`ty : Module 8 Q`ty in one box
Serial No. : Box Serial No. See next page for detail description.
Date : Packing Date

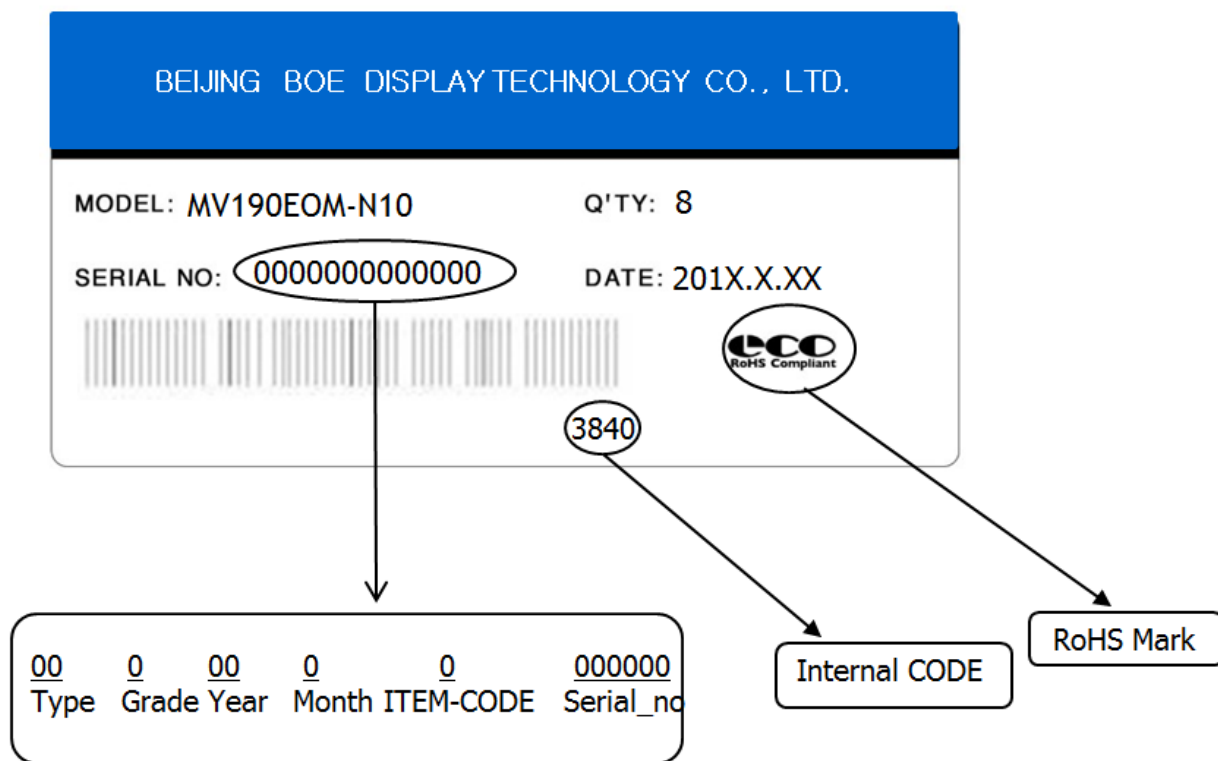

15.0 APPENDIX

Figure 1. Measurement Set Up

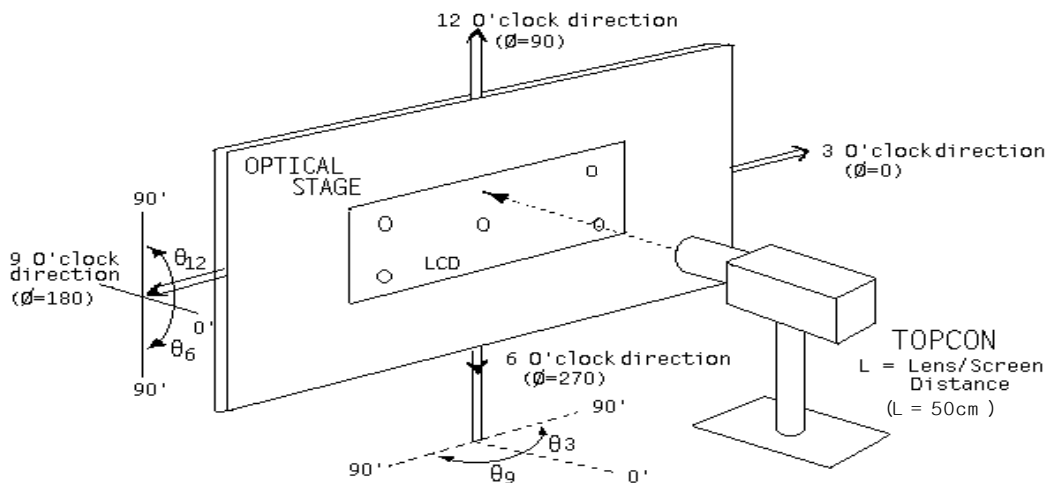

Figure 2. White Luminance and Uniformity Measurement Locations (9 points)

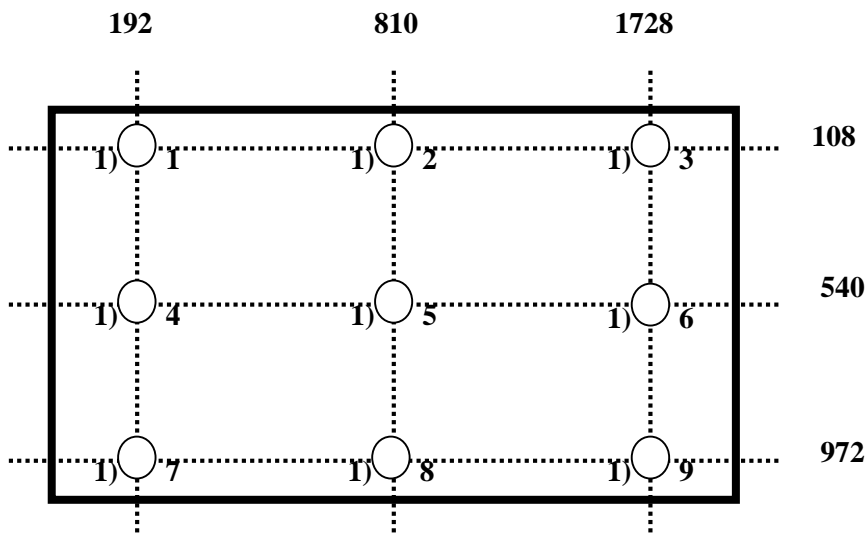

Figure 3. Response Time Testing

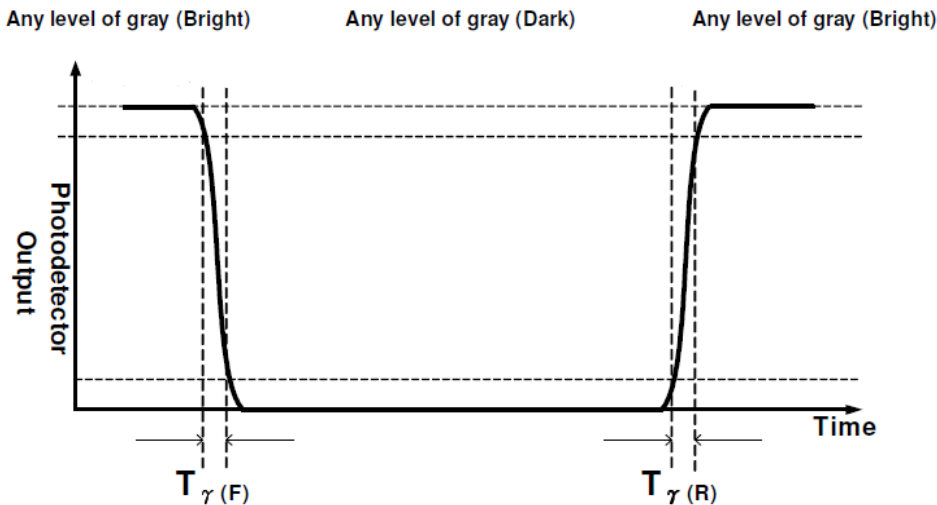
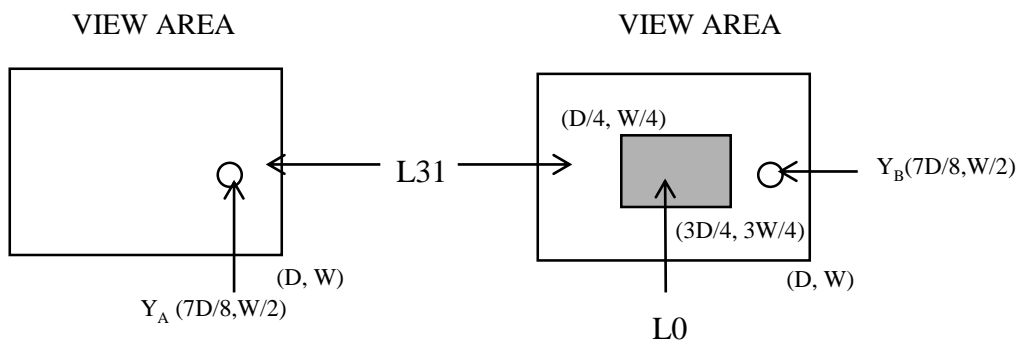

Figure 4. Cross Modulation Test Description



$$\text{Cross-Talk (\%)} = \left| \frac{Y_B - Y_A}{Y_A} \right| \times 100$$

Where: Y_A = Initial luminance of measured area (cd/m^2)

Y_B = Subsequent luminance of measured area (cd/m^2)

The location measured will be exactly the same in both patterns

Figure 5. TFT-LCD Module Outline Dimensions (Front view)

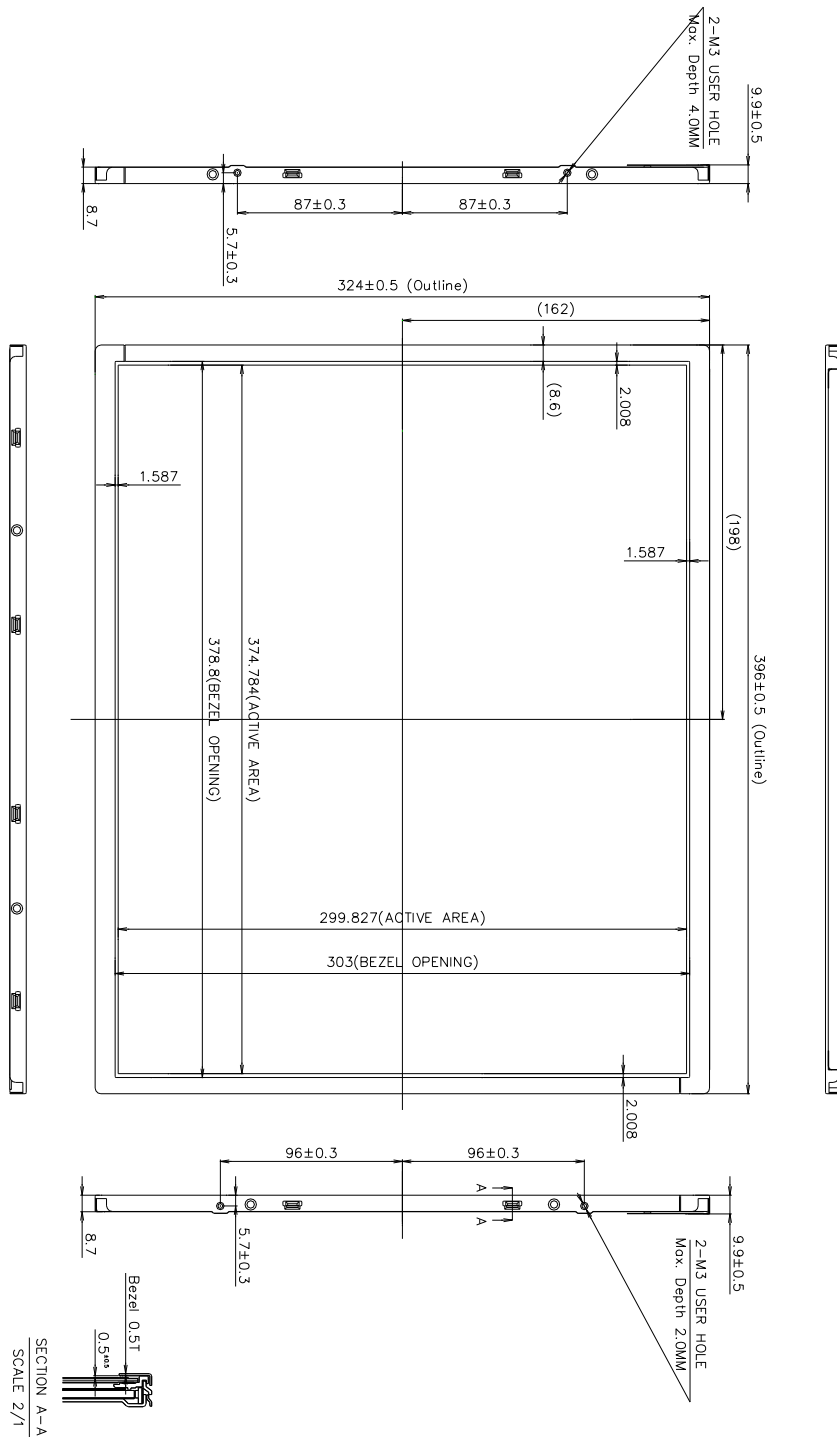

Figure 6. TFT-LCD Module Outline Dimensions (Rear view)

