

SPECIFICATION FOR APPROVAL

() Preliminary Specification

(●) Final Specification

| | |
|-------|----------------------|
| Title | 43.0" QWUXGA TFT LCD |
|-------|----------------------|

| | |
|-------|---------------|
| BUYER | General |
| MODEL | LD430EQE-FLA1 |

| | |
|----------|----------------------|
| SUPPLIER | LG Display Co., Ltd. |
| *MODEL | LD430EQE |
| SUFFIX | FLA1 (RoHS Verified) |

| APPROVED BY | SIGNATURE DATE |
|-------------|-------------------|
| / | _____ |
| / | _____ |
| / | _____ |

Please return 1 copy for your confirmation with your signature and comments.

| APPROVED BY | SIGNATURE DATE |
|-----------------------------|---|
| JaeBum Chun / Team Leader |  2019. 11. 01 |
| REVIEWED BY | |
| HyoGil Lee / Project Leader |  2019. 11. 01 |
| PREPARED BY | |
| ByoungSon Ryu / Engineer |  2019. 11. 01 |

**TV Product Development Dept.
LG Display Co., Ltd.**

Product Specification

CONTENTS

| Number | ITEM | Page |
|--------|---------------------------------------|------|
| | COVER | 0 |
| | CONTENTS | 1 |
| | RECORD OF REVISIONS | 2 |
| 1 | GENERAL DESCRIPTION | 3 |
| 2 | ABSOLUTE MAXIMUM RATINGS | 4 |
| 3 | ELECTRICAL SPECIFICATIONS | 5 |
| 3-1 | ELECTRICAL CHARACTERISTICS | 5 |
| 3-2 | INTERFACE CONNECTIONS | 7 |
| 3-3 | SIGNAL TIMING SPECIFICATIONS | 9 |
| 3-4 | V by One SIGNAL SPECIFICATIONS | 10 |
| 3-5 | COLOR DATA REFERENCE | 12 |
| 3-6 | POWER SEQUENCE | 13 |
| 4 | OPTICAL SPECIFICATIONS | 14 |
| 5 | MECHANICAL CHARACTERISTICS | 18 |
| 6 | RELIABILITY | 21 |
| 7 | INTERNATIONAL STANDARDS | 22 |
| 7-1 | SAFETY | 22 |
| 7-2 | ENVIRONMENT | 22 |
| 8 | PACKING | 23 |
| 8-1 | INFORMATION OF LCM LABEL | 23 |
| 8-2 | PACKING FORM | 23 |
| 9 | PRECAUTIONS | 24 |
| 9-1 | MOUNTING PRECAUTIONS | 24 |
| 9-2 | OPERATING PRECAUTIONS | 24 |
| 9-3 | ELECTROSTATIC DISCHARGE CONTROL | 25 |
| 9-4 | PRECAUTIONS FOR STRONG LIGHT EXPOSURE | 25 |
| 9-5 | STORAGE | 25 |
| 9-6 | OPERAGING CONDITION GUIDE | 25 |

Product Specification

1. General Description

The LD430EQE is a Color Active Matrix Liquid Crystal Display with an integral Light Emitting Diode (LED) backlight system. The matrix employs a-Si Thin Film Transistor as the active element. It is a transmissive display type which is operating in the normally black mode. It has a 42.51 inch diagonally measured active display area with QWUXGA resolution (2160 vertical by 3840 horizontal pixel array). Each pixel is divided into Red, Green and Blue sub-pixels or dots which are arrayed in vertical stripes. Gray scale or the luminance of the sub-pixel color is determined with a 10-bit gray scale signal for each dot. Therefore, it can present a palette of more than 1.06Billion colors.

It has been designed to apply the 10-bit 8 Lane V by One interface.

It is intended to support LCD TV, PCTV where high brightness, super wide viewing angle, high color gamut, high color depth and fast response time are important.

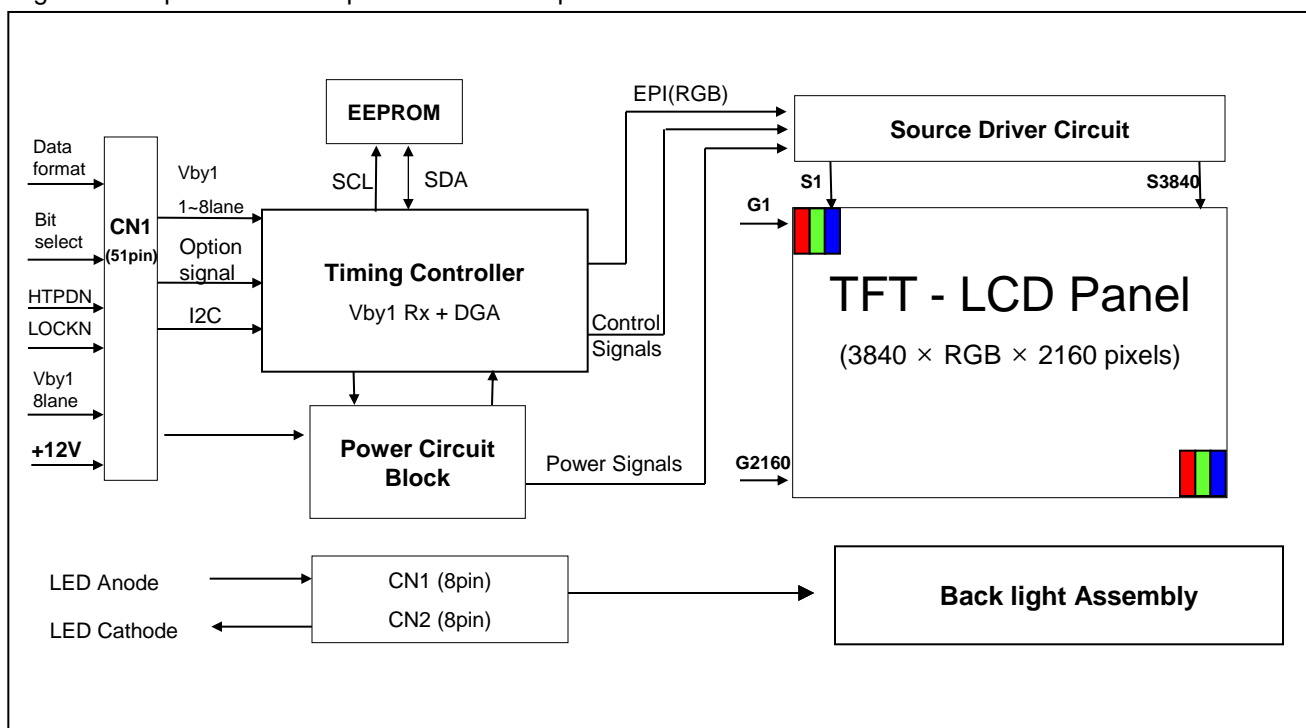

| | |
|-----------------------|---|
| Active Screen Size | 42.51 inches(1,079.75 mm) diagonal |
| Outline Dimension | 962.0 (H) x 554.8 (V) x 9.6(D) (Typ.) |
| Pixel Pitch | 0.2451 mm x 0.2451 mm |
| Pixel Format | 3840 horiz. by 2160 vert. Pixels, RGB stripe arrangement |
| Color Depth | 10bit(D), 1.06Billion colors |
| Luminance, White | 400cd/m2 (Center 1point ,Typ.) |
| Viewing Angle (CR>10) | Viewing angle free (R/L 178 (Min.), U/D 178 (Min.)) |
| Power Consumption | Total 58.49W (Typ) [Logic= 5.49W, LED Backlight=53W (IF_cathode=55mA)] |
| Weight | 8.3 kg (Typ.) 8.7 kg (Max.) |
| Display Mode | Transmissive mode, Normally black |
| Surface Treatment | Hard coating(3H), Anti-glare treatment of the front polarizer(Haze 28%(Typ.)) |

Product Specification

2. Absolute Maximum Ratings

The following items are maximum values which, if exceeded, may cause faulty operation or permanent damage to the LCD module.

Table 1. ABSOLUTE MAXIMUM RATINGS

| Parameter | | Symbol | Value | | Unit | Notes |
|--------------------------------|-----------------|--------------------|-------|-------|-----------------|-------|
| | | | Min | Max | | |
| Power Input Voltage | LCD Circuit | V _{LCD} | -0.3 | +14.0 | V _{DC} | 1 |
| LED Input Voltage | Forward Voltage | V _F | - | +64.4 | V _{DC} | |
| T-Con Option Selection Voltage | | V _{LOGIC} | -0.3 | +4.0 | V _{DC} | |
| Operating Temperature | | T _{OP} | 0 | +50 | °C | 2,3 |
| Storage Temperature | | T _{ST} | -20 | +60 | °C | |
| Panel Front Temperature | | T _{SUR} | - | +68 | °C | 4 |
| Operating Ambient Humidity | | H _{OP} | 10 | 90 | %RH | 2,3 |
| Storage Humidity | | H _{ST} | 5 | 90 | %RH | |

- Notes
1. Ambient temperature condition ($T_a = 25 \pm 2 \text{ }^\circ\text{C}$)
 2. Temperature and relative humidity range are shown in the figure below.
Wet bulb temperature should be Max 39°C, and no condensation of water.
 3. The maximum operating temperatures is based on the test condition that the surface temperature of display area is less than or equal to 68°C with LCD module alone in a temperature controlled chamber. Thermal management should be considered in final product design to prevent the surface temperature of display area from being over 68°C. The range of operating temperature may be degraded in case of improper thermal management in final product design.

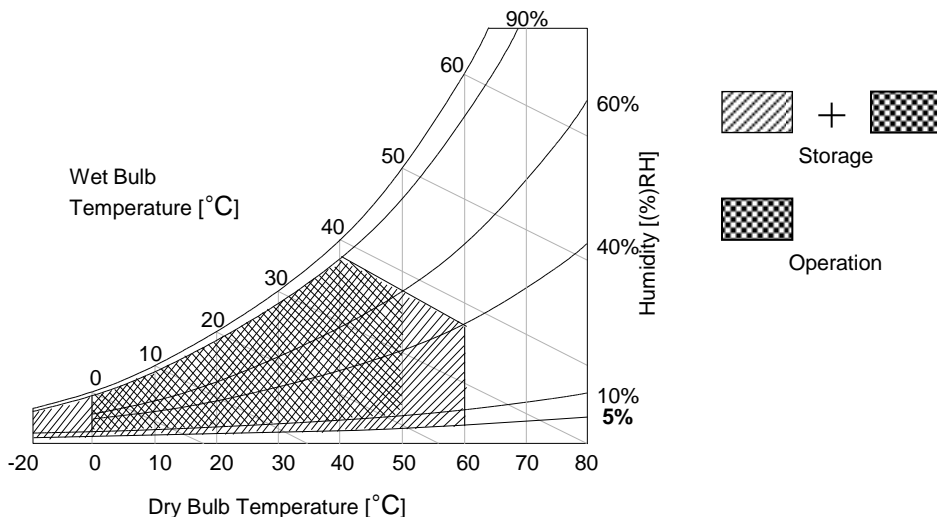

Product Specification

3. Electrical Specifications

3-1. Electrical Characteristics

It requires two power inputs. One is employed to power for the LCD circuit. The other is used for the LED backlight and LED Driver circuit.

Table 2. ELECTRICAL CHARACTERISTICS

| Parameter | Symbol | Value | | | Unit | notes | |
|-----------------------------------|--------------------|-----------------|-------|-------|------|-------|--|
| | | Min | Typ | Max | | | |
| Circuit : | | | | | | | |
| Power Input Voltage | V _{LCD} | 10.8 | 12.0 | 13.2 | Vdc | | |
| Power Input Current | I _{LCD} | - | 458 | 595 | mA | 1 | |
| | | - | 1,110 | 1,443 | mA | 2 | |
| T-CON Option Selection Voltage | Input High Voltage | V _{IH} | 2.7 | - | 3.6 | VDC | |
| | Input Low Voltage | V _{IL} | 0 | - | 0.7 | VDC | |
| Power Consumption | P _{LCD} | - | 5.49 | 7.14 | Watt | 1 | |
| | | - | 13.32 | 17.32 | Watt | 2 | |
| Rush current | I _{RUSH} | - | - | 10 | A | 3 | |

Notes

- Notes
1. The specified current and power consumption are under the V_{LCD}=12.0V, Ta=25 ± 2°C, f_v=60Hz condition, and mosaic pattern(8 x 6) is displayed and f_v is the frame frequency.
 2. The current is specified at the maximum current pattern.
 3. The duration of rush current is about 2ms and rising time of power input is 0.5ms (min.).
 4. Ripple voltage level is recommended under ±5% of typical voltage

White : 1023 Gray
Black : 0 Gray

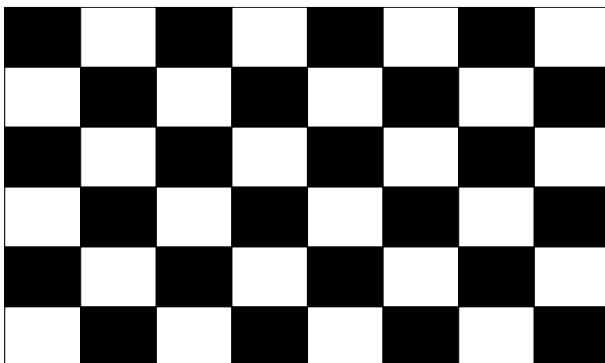

Mosaic Pattern(8 x 6)

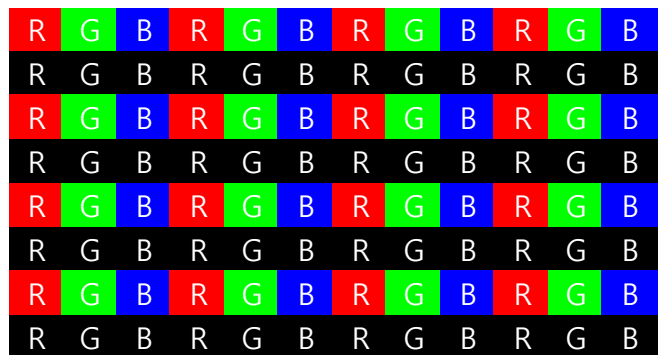

Max Current Pattern

Product Specification

Table 3. ELECTRICAL CHARACTERISTICS (Continue)

Ta=25±2°C, On Duty 100%

| Parameter | Symbol | Values | | | Unit | Note | |
|---------------------------------|---------|-------------------|--------|---------|-------|------|------|
| | | Min | Typ | Max | | | |
| Backlight Assembly : | | | | | | | |
| Forward Current (one array) | Anode | $I_{F (anode)}$ | | 165 | | mAdc | ±5% |
| | Cathode | $I_{F (cathode)}$ | | 55 | | mAdc | 2, 3 |
| Forward Voltage | | V_F | 151.1 | 160.1 | 170.1 | Vdc | 4 |
| Forward Voltage Variation | | ΔV_F | | | 1.7 | Vdc | 5 |
| Power Consumption | | P_{BL} | - | 52.8 | 56.1 | W | 6 |
| Burst Dimming Duty | | On duty | 1 | | 100 | % | |
| Burst Dimming Frequency | | 1/T | 95 | 100/120 | 182 | Hz | 7 |
| LED Array : (APPENDIX-V) | | | | | | | |
| Life Time | | | 30,000 | | | Hrs | 8 |

Notes :The design of the LED driver must have specifications for the LED array in LCD Assembly.

The electrical characteristics of LED driver are based on Constant Current driving type.

The performance of the LED in LCM, for example life time or brightness, is extremely influenced by the characteristics of the LED Driver. So, all the parameters of an LED driver should be carefully designed.

When you design or order the LED driver, please make sure unwanted lighting caused by the mismatch of the LED and the driver (no lighting, flicker, etc) has never been occurred. When you confirm it, the LCD-Assembly should be operated in the same condition as installed in your instrument.

1. Electrical characteristics are based on LED Array specification.

2. Specified values are defined for a Backlight Assembly. (IBL :2 LED array/LCM)

Electrical characteristics are determined after the unit has been 'ON' and stable for approximately 60 minutes at 25±2°C. The specified temperature, optical, and power consumption are under the typical supply input voltage, current & VBR (Duty 100%), it is total power consumption.

3. Each LED array has one anode terminal and three cathode terminals.

The forward current(I_F) of the anode terminal is 165mA and it supplies 55mA into three strings, respectively

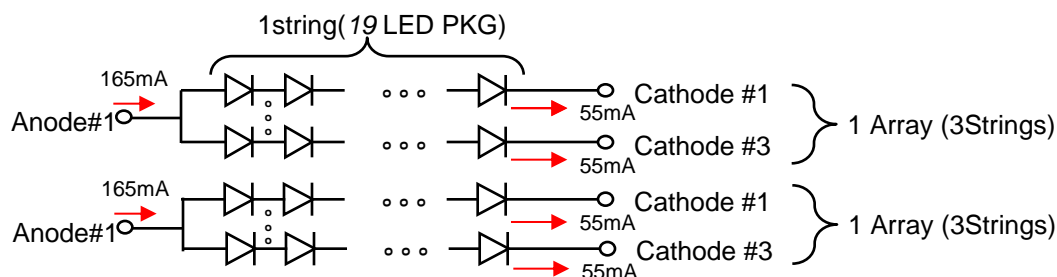

4. The forward voltage(V_F) of LED array depends on ambient temperature (Appendix-V)

5. ΔV_F means Max V_F -Min V_F in one Backlight. So V_F variation in a Backlight isn't over Max. 1.7V **based on duty 100%**

6. Maximum level of power consumption is measured at initial turn on.

Typical level of power consumption is measured after 1hrs aging at 25 ± 2°C.

7. The reference method of burst dimming duty ratio.

It is recommended to use synchronous V-sync frequency to prevent waterfall ($V_{sync} * 1 = \text{Burst Frequency}$)

Though PWM frequency is over 182Hz (max252Hz), function of backlight is not affected.

8. The life time is determined as the time at which brightness of the LED is 50% compared to that of initial value at the typical LED current on condition of continuous operating at 25 ± 2°C, based on duty 100%.

Product Specification

3-2. Interface Connections

This LCD module employs two kinds of interface connection, 51-pin connector is used for the module electronics and two 8-pin connectors are used for the integral backlight system.

3-2-1. LCD Module

- LCD Connector(CN1): FI-RE51S-HF(manufactured by JAE) or GT05P-51S-H38(manufactured by LSM) or IS050-C51B-C39(manufactured by UJU)
- Mating Connector : FI-R51HL(manufactured by JAE) or compatible

Table 4. MODULE CONNECTOR(CN1) PIN CONFIGURATION

| No | Symbol | Description | No | Symbol | Description |
|----|-------------------------|--|----|--------|-------------------------|
| 1 | VLCD | Power Supply +12.0V | 27 | GND | Ground |
| 2 | VLCD | Power Supply +12.0V | 28 | Rx0n | V-by-One HS Data Lane 0 |
| 3 | VLCD | Power Supply +12.0V | 29 | Rx0p | V-by-One HS Data Lane 0 |
| 4 | VLCD | Power Supply +12.0V | 30 | GND | Ground |
| 5 | VLCD | Power Supply +12.0V | 31 | Rx1n | V-by-One HS Data Lane 1 |
| 6 | VLCD | Power Supply +12.0V | 32 | Rx1p | V-by-One HS Data Lane 1 |
| 7 | VLCD | Power Supply +12.0V | 33 | GND | Ground |
| 8 | VLCD | Power Supply +12.0V | 34 | Rx2n | V-by-One HS Data Lane 2 |
| 9 | NC | NO CONNECTION | 35 | Rx2p | V-by-One HS Data Lane 2 |
| 10 | GND | Ground | 36 | GND | Ground |
| 11 | GND | Ground | 37 | Rx3n | V-by-One HS Data Lane 3 |
| 12 | GND | Ground | 38 | Rx3p | V-by-One HS Data Lane 3 |
| 13 | GND | Ground | 39 | GND | Ground |
| 14 | NC | NO CONNECTION | 40 | Rx4n | V-by-One HS Data Lane 4 |
| 15 | NC | NO CONNECTION | 41 | Rx4p | V-by-One HS Data Lane 4 |
| 16 | NC | NO CONNECTION | 42 | GND | Ground |
| 17 | NC | NO CONNECTION | 43 | Rx5n | V-by-One HS Data Lane 5 |
| 18 | NC | NO CONNECTION | 44 | Rx5p | V-by-One HS Data Lane 5 |
| 19 | NC | NO CONNECTION | 45 | GND | Ground |
| 20 | NC | NO CONNECTION | 46 | Rx6n | V-by-One HS Data Lane 6 |
| 21 | Bit SEL | 'H' or NC= 10bit(D) , 'L' = 8bit | 47 | Rx6p | V-by-One HS Data Lane 6 |
| 22 | Data format (Vx1 Input) | 'L' : Non division, 'H' 2 division | 48 | GND | Ground |
| 23 | AGP or NSB | 'H' or NC : AGP 'L' : NSB (No signal Black) | 49 | Rx7n | V-by-One HS Data Lane 7 |
| 24 | NC | NO CONNECTION | 50 | Rx7p | V-by-One HS Data Lane 7 |
| 25 | HTPDN | Hot plug detect | 51 | GND | Ground |
| 26 | LOCKN | Lock detect | - | - | - |

- Note*
1. All GND (ground) pins should be connected together to the LCD module's metal frame.
 2. All Input levels of V-by-One signals are based on the V-by-One-HS Standard Version 1.4
 3. #14~ #20 NC(No Connection) : These pins are used only for LGD (Do not connect)
 4. About specific pin(#22), Please see the Appendix VI.
 5. Specific pin No. #23 is used for "No signal detection" of system signal interface.
It should be GND for NSB (No Signal Black) while the system interface signal is not.
If this pin is "H", LCD Module displays AGP(Auto Generation Pattern).

Product Specification

3-2-2. Backlight Module

[CN201]

- 1) LED Array assy Connector (Plug)
: HS100-L08N-N62 (black color, manufactured by UJU)
- 2) Mating Connector (Receptacle)
: IS100-L08T-C46 (black color, manufactured by UJU)

[CN202]

- 1) LED Array assy Connector (Plug)
: HS100-L08N-N62-A (natural color, manufactured by UJU)
- 2) Mating Connector (Receptacle)
: IS100-L08T-C46-A (natural color, manufactured by UJU)

Table 5. BACKLIGHT CONNECTOR PIN CONFIGURATION(CN201,CN202)

| No | Symbol | Description | Note |
|----|------------|-----------------------------|------|
| 1 | L1 Cathode | LED Output Current | |
| 2 | L2 Cathode | LED Output Current | |
| 3 | L3 Cathode | LED Output Current | |
| 4 | N.C | Open | |
| 5 | N.C | Open | |
| 6 | N.C | Open | |
| 7 | N.C | Open | |
| 8 | Anode_L | LED Input Current for L1~L3 | |

| No | Symbol | Description | Note |
|----|------------|-----------------------------|------|
| 1 | Anode_R | LED Input Current for R1~R3 | |
| 2 | N.C | Open | |
| 3 | N.C | Open | |
| 4 | N.C | Open | |
| 5 | N.C | Open | |
| 6 | R3 Cathode | LED Output Current | |
| 7 | R2 Cathode | LED Output Current | |
| 8 | R1 Cathode | LED Output Current | |

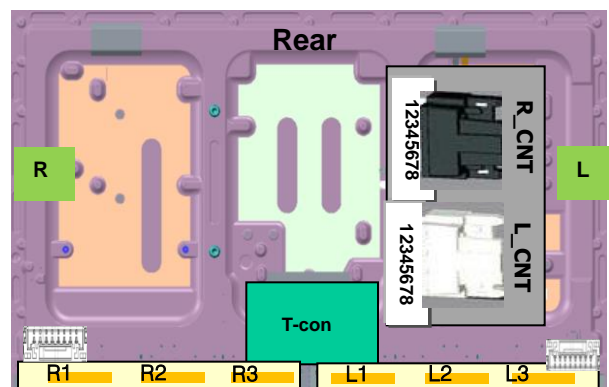
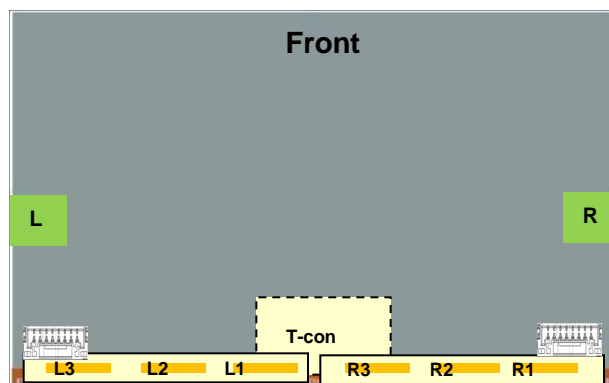

Product Specification

3-3. Signal Timing Specifications

Table 6 shows the signal timing required at the input of the Vx1 transmitter. All of the interface signal timings should be satisfied with the following specification for normal operation.

Table 6. TIMING TABLE (DE Only Mode)

| ITEM | | Symbol | Min | Typ | Max | Unit | Note |
|------------|----------------|----------|------|------|------|-------|--------|
| Horizontal | Display Period | t_{HV} | 480 | 480 | 480 | tCLK | 3840/8 |
| | Blank | t_{HB} | 50 | 70 | 120 | tCLK | 1 |
| | Total | t_{HP} | 530 | 550 | 600 | tCLK | |
| Vertical | Display Period | t_{VV} | 2160 | 2160 | 2160 | Lines | |
| | Blank | t_{VB} | 40 | 90 | 600 | Lines | 1 |
| | Total | t_{VP} | 2200 | 2250 | 2760 | Lines | |

| ITEM | | Symbol | Min | Typ | Max | Unit | Note |
|-----------|------------|-----------|-------|-------|-------|------|-------|
| Frequency | DCLK | f_{CLK} | 60 | 74.25 | 78.00 | MHz | 594/8 |
| | Horizontal | f_H | 121.8 | 135 | 140 | KHz | 2 |
| | Vertical | f_V | 47 | 60 | 63 | Hz | 2 |

notes: 1. The input of HSYNC & VSYNC signal does not have an effect on normal operation (DE Only Mode).
If you use spread spectrum of EMI, add some additional clock to minimum value for clock margin.

2. The performance of the electro-optical characteristics may be influenced by variance of the vertical refresh rate and the horizontal frequency

3. Spread Spectrum Rate (SSR) is limited to $\pm 0.5\%$ center spread at 30KHz

※ Timing should be set based on clock frequency.

Product Specification

3-4. V by One input signal Characteristics

3-4-1. V by One Input Signal Timing Diagram

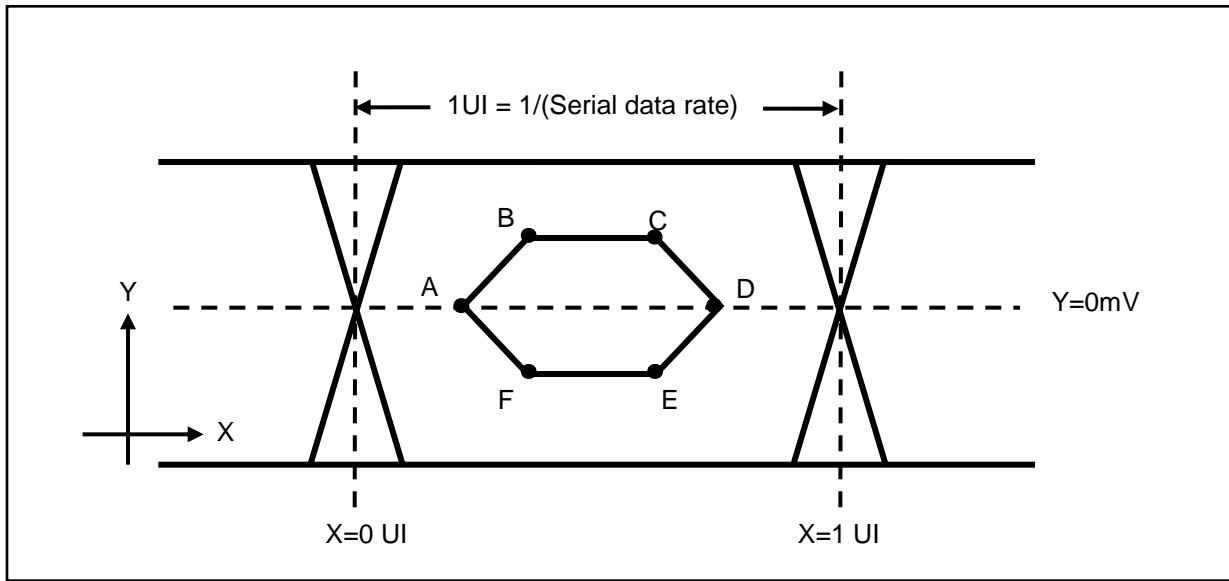

Table7. Eye Mask Specification

| | X[UI] | Note | Y[mV] | Note |
|---|------------|------|-------|------|
| A | 0.25 (max) | 2 | 0 | - |
| B | 0.3 (max) | 2 | 50 | 3 |
| C | 0.7(min) | 3 | 50 | 3 |
| D | 0.75(min) | 3 | 0 | - |
| E | 0.7(min) | 3 | -50 | 3 |
| F | 0.3(max) | 2 | -50 | 3 |

notes 1. All Input levels of V by One signals are based on the V by One HS Standard Ver. 1.4

2. This is allowable maximum value.

3. This is allowable minimum value.

4. The eye diagram is measured by the oscilloscope and receiver CDR characteristic must be emulated.

- PLL bandwidth : 20 Mhz

- Damping Factor : 1.5

Product Specification

3-4-2. V by One Input Signal Characteristics

1) DC Specification

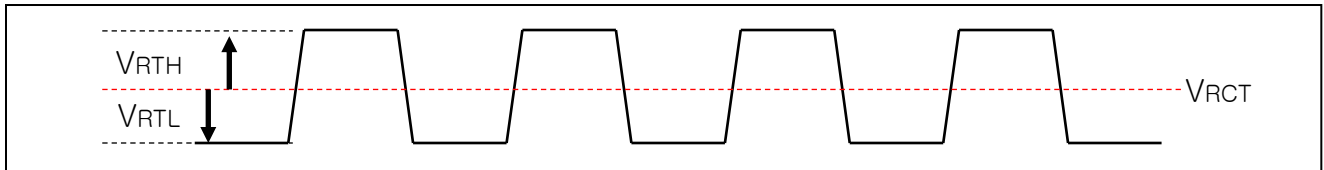

| Description | Symbol | Min | Max | Unit |
|---------------------------------------|--------|-----|-----|------|
| CML Differential input High threshold | VRTH | - | 50 | mV |
| CML Differential input Low threshold | VRTL | -50 | - | mV |
| CML common mode Bias Voltage | VRCT | 0.6 | 0.8 | V |

2) AC Specification

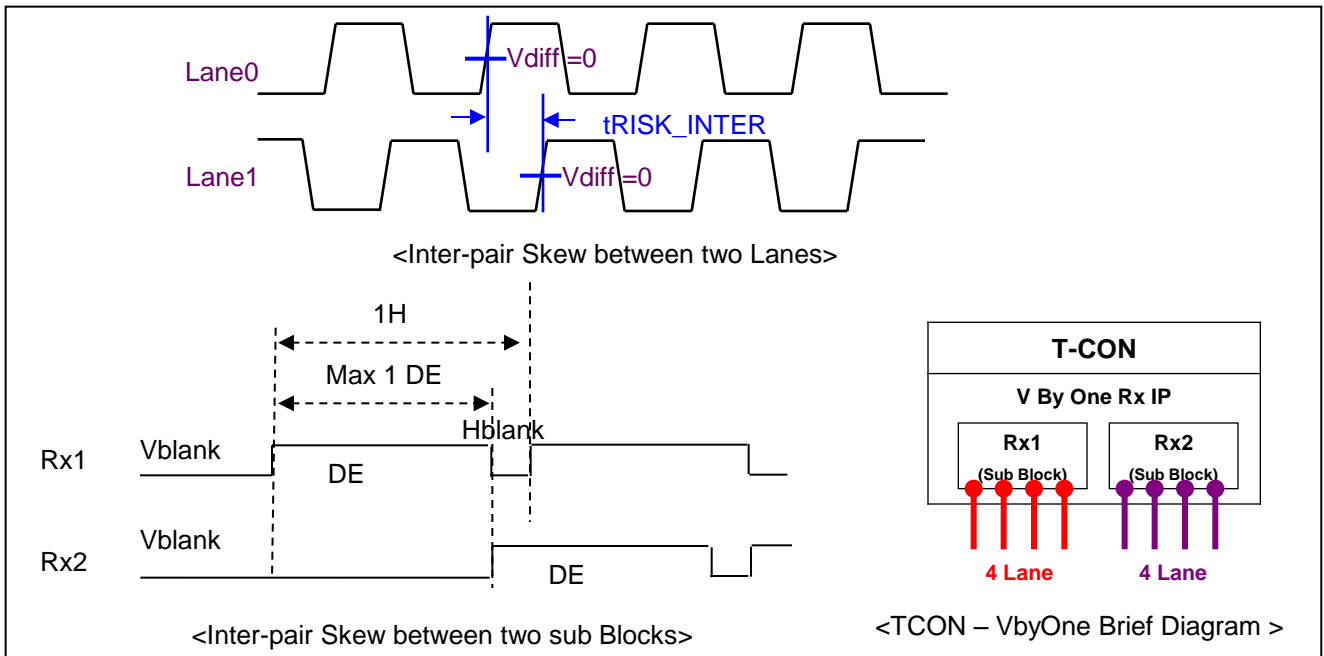

| Description | Symbol | Min | Max | Unit | notes |
|---|-------------|-----|-----|------|-------|
| Allowable inter-pair skew between lanes | tRISK_INTER | - | 5 | UI | 1,3 |
| Allowable iner-pair skew between sub-blocks | tRISK_BLOCK | - | 1 | DE | 1,4 |

Notes 1.1UI = 1/serial data rate

2. it is the time difference between the true and complementary single-ended signals.
3. it is the time difference of the differential voltage between any two lanes in one sub block.
4. it is the time difference of the differential voltage between any two blocks in one IP.

Product Specification

3-5. Color Data Reference

The brightness of each primary color (red, green, blue) is based on the 10bit or 8bit gray scale data input for the color. The higher binary input, the brighter the color. Table 8 provides a reference for color versus data input.

Table 8. COLOR DATA REFERENCE

| Packer input & Unpacker output | | 30bpp RGB (10bit) | 24bpp RGB (8bit) |
|--------------------------------|-------|-------------------|------------------|
| Byte0 | D[0] | R[2] | R[0] |
| | D[1] | R[3] | R[1] |
| | D[2] | R[4] | R[2] |
| | D[3] | R[5] | R[3] |
| | D[4] | R[6] | R[4] |
| | D[5] | R[7] | R[5] |
| | D[6] | R[8] | R[6] |
| | D[7] | R[9] | R[7] |
| Byte1 | D[8] | G[2] | G[0] |
| | D[9] | G[3] | G[1] |
| | D[10] | G[4] | G[2] |
| | D[11] | G[5] | G[3] |
| | D[12] | G[6] | G[4] |
| | D[13] | G[7] | G[5] |
| | D[14] | G[8] | G[6] |
| | D[15] | G[9] | G[7] |
| Byte2 | D[16] | B[2] | B[0] |
| | D[17] | B[3] | B[1] |
| | D[18] | B[4] | B[2] |
| | D[19] | B[5] | B[3] |
| | D[20] | B[6] | B[4] |
| | D[21] | B[7] | B[5] |
| | D[22] | B[8] | B[6] |
| | D[23] | B[9] | B[7] |
| Byte3 | D[24] | Don't care | |
| | D[25] | Don't care | |
| | D[26] | B[0] | |
| | D[27] | B[1] | |
| | D[28] | G[0] | |
| | D[29] | G[1] | |
| | D[30] | R[0] | |
| | D[31] | R[1] | |

Product Specification

3-6. Power Sequence

3-6-1. LCD Driving circuit

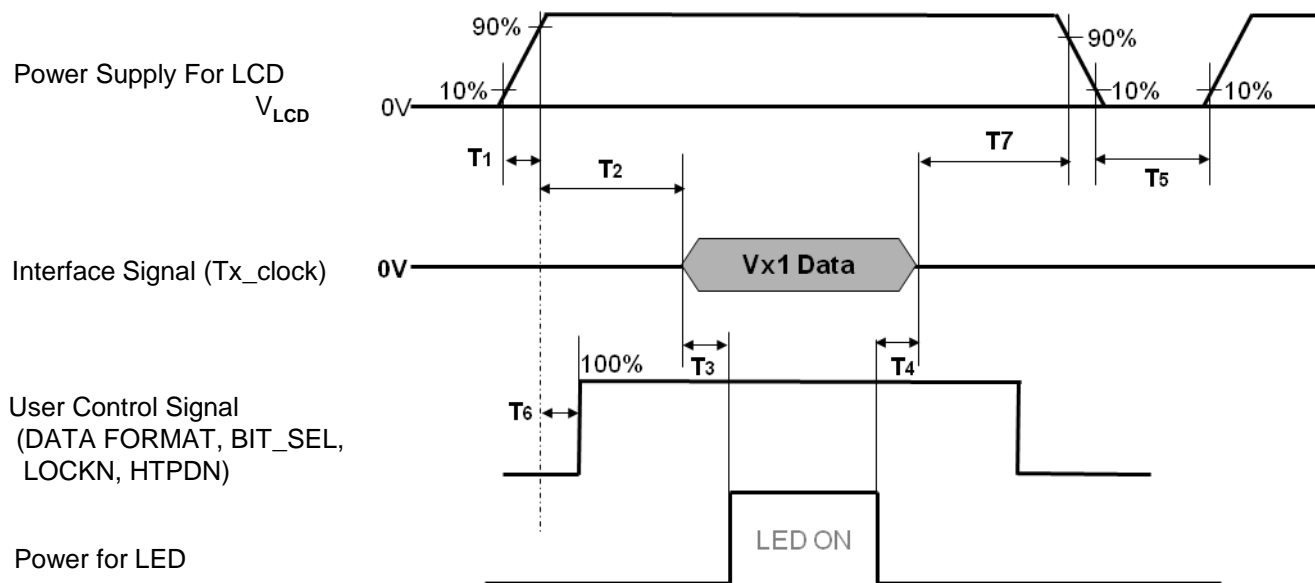

Table 9. POWER SEQUENCE

| Parameter | Value | | | Unit | Note |
|-----------|-------|-----|-----|------|------|
| | Min | Typ | Max | | |
| T1 | 0.5 | - | 20 | ms | 1 |
| T2 | 0 | - | - | ms | 2 |
| T3 | 400 | - | - | ms | 3 |
| T4 | 100 | - | - | ms | 3 |
| T5 | 1.0 | - | - | s | 4 |
| T6 | 0 | - | T2 | ms | 5 |
| T7 | 0 | - | - | ms | 6 |

- Note :
1. Even though T1 is over the specified value, there is no problem if I2T spec of fuse is satisfied.
 2. If T2 is satisfied with specification after removing LVDS Cable, there is no problem.
 3. The T3 / T4 is recommended value, the case when failed to meet a minimum specification, abnormal display would be shown. There is no reliability problem.
 4. T5 should be measured after the Module has been fully discharged between power off and on period.
 5. If the on time of signals (Interface signal and user control signals) precedes the on time of Power (V_{LCD}), it will be happened abnormal display. When T6 is NC status, T6 doesn't need to be measured.
 6. It is recommendation specification that T7 has to be 0ms as a minimum value.
 - ※ Please avoid floating state of interface signal at invalid period.
 - ※ When the power supply for LCD (VLCD) is off, be sure to pull down the valid and invalid data to 0V.

Product Specification

4. Optical Specification

Optical characteristics are determined after the unit has been 'ON' and stable in a dark environment at $25\pm 2^{\circ}\text{C}$. The values are specified at distance 50cm from the LCD surface at a viewing angle of Φ and θ equal to 0° . FIG. 1 shows additional information concerning the measurement equipment and method.

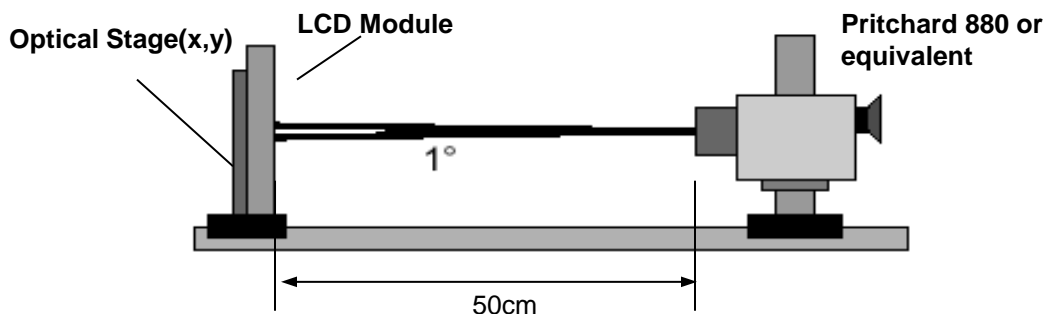

FIG. 1 Optical Characteristic Measurement Equipment and Method

$T_a = 25\pm 2^{\circ}\text{C}$, $V_{\text{LCD}} = 12.0\text{V}$, $f_v = 60\text{Hz}$, $D_{\text{clk}} = 74.25\text{MHz}$,
 $I_{\text{F_cathode}} = 55\text{mA}$

Table 10. OPTICAL CHARACTERISTICS

| Parameter | | Symbol | | Value | | | Unit | notes | |
|--------------------------------|-------------------|-----------------------------|----|---------------------|--------|--------------|-----------------|--------|---|
| | | | | Min | Typ | Max | | | |
| Contrast Ratio | | CR | | 700 | 1000 | - | | 1 | |
| Surface Luminance, white | | L_{WH} | 2D | 320 | 400 | - | cd/m^2 | 2 | |
| Luminance Variation | | δ_{WHITE} | 9P | 80 | - | - | | 3 | |
| Response Time | Variation | G to G _σ | | | 6 | 9 | ms | 4 | |
| | Gray to Gray (BW) | G to G BW | | | 9 | 13 | | 5 | |
| Color Coordinates [CIE1931] | RED | Rx | | Typ -0.03 | 0.643 | Typ +0.03 | | | |
| | | Ry | | | 0.332 | | | | |
| | GREEN | Gx | | | 0.307 | | | | |
| | | Gy | | | 0.620 | | | | |
| | BLUE | Bx | | | 0.153 | | | | |
| | | By | | | 0.056 | | | | |
| | WHITE | Wx | | | 0.279 | | | | |
| Wy | | 0.292 | | | | | | | |
| Color Temperature | | | | | 10,000 | | K | | |
| Color Gamut | | | | | 72 | | % | | |
| Viewing Angle | 2D (CR>10) | right($\phi=0^{\circ}$) | | θ_r (x axis) | 89 | - | - | degree | 6 |
| | | left ($\phi=180^{\circ}$) | | θ_l (x axis) | 89 | - | - | | |
| | | up ($\phi=90^{\circ}$) | | θ_u (y axis) | 89 | - | - | | |
| | | down ($\phi=270^{\circ}$) | | θ_d (y axis) | 89 | - | - | | |
| Gray Scale | | | | | - | - | - | | 7 |

Product Specification

Note : 1. Contrast Ratio(CR) is defined mathematically as :

$$\text{Contrast Ratio} = \frac{\text{Surface Luminance with all white pixels}}{\text{Surface Luminance with all black pixels}}$$

It is measured at center 1-point.

2. Optical characteristic is determined after the unit has been 'ON' and 1 Hour after lighting the backlight in a dark environment at $25 \pm 2^\circ\text{C}$. Surface luminance is the luminance value at center 1-point across the LCD surface 50cm from the surface with all pixels displaying white. For more information see the FIG. 2.
3. The variation in surface luminance, δ WHITE is defined as :
 δ WHITE(9P) = Minimum ($L_{on1}, L_{on2} \sim L_{on8}, L_{on9}$) / Maximum ($L_{on1}, L_{on2} \sim L_{on8}, L_{on9}$) * 100
 Where L_{on1} to L_{on9} are the luminance with all pixels displaying white at 9 locations .
 For more information, see the FIG. 2.
4. Response time is the time required for the display to transit from any gray to white (Rise Time, Tr_R) and from any gray to black (Decay time, Tr_D). For additional information see the FIG. 3.
 ※ G to G_{BW} Spec stands for average value of all measured points.
 Photo Detector : RD-80S / Field : 2°
5. G to G σ is Variation of Gray to Gray response time composing a picture

$$G \text{ to } G (\sigma) = \sqrt{\frac{\sum(X_i - u)^2}{N}}$$

X_i = Individual Data
 u = Data average
 N : The number of Data

6. Viewing angle is the angle at which the contrast ratio is greater than 10. The angles are determined for the horizontal or x axis and the vertical or y axis with respect to the z axis which is normal to the LCD module surface. For more information, see the FIG. 4.
7. Gray scale specification
 Gamma Value is approximately 2.2. For more information, see the Table 11

Table 11. GRAY SCALE SPECIFICATION

| Gray Level | Luminance [%] (Typ) |
|------------|---------------------|
| L0 | 0.1 |
| L63 | 0.27 |
| L127 | 1.04 |
| L191 | 2.49 |
| L255 | 4.68 |
| L319 | 7.66 |
| L383 | 11.5 |
| L447 | 16.1 |
| L511 | 21.6 |
| L575 | 28.1 |
| L639 | 35.4 |
| L703 | 43.7 |
| L767 | 53.0 |
| L831 | 63.2 |
| L895 | 74.5 |
| L959 | 86.7 |
| L1023 | 100 |

Product Specification

Measuring point for surface luminance & measuring point for luminance variation.

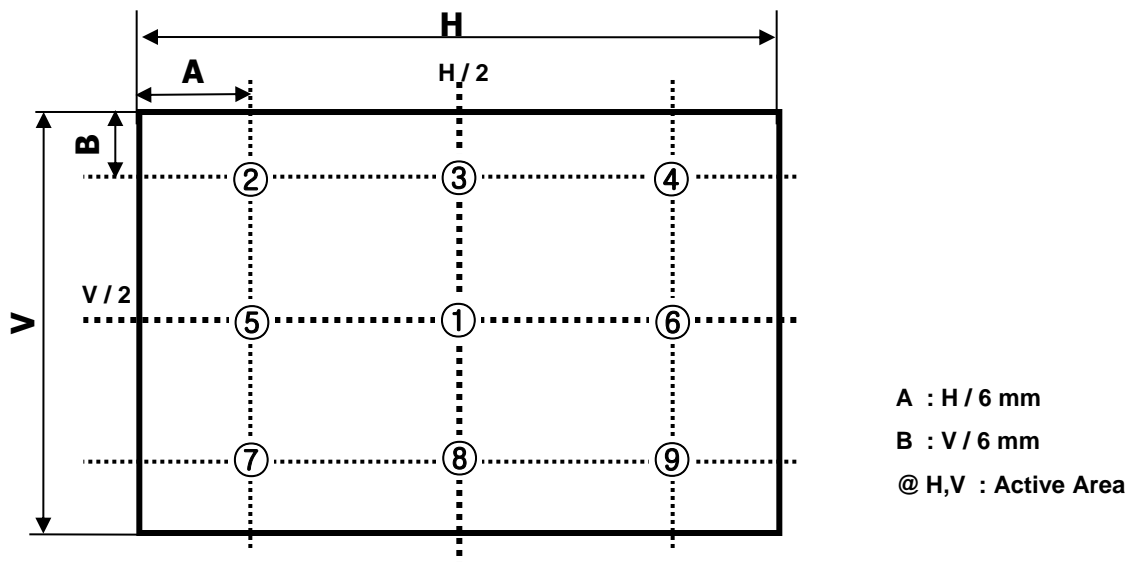

FIG. 2 9 Points for Luminance Measure

Response time is defined as the following figure and shall be measured by switching the input signal for "Gray(N)" and "Black or White".

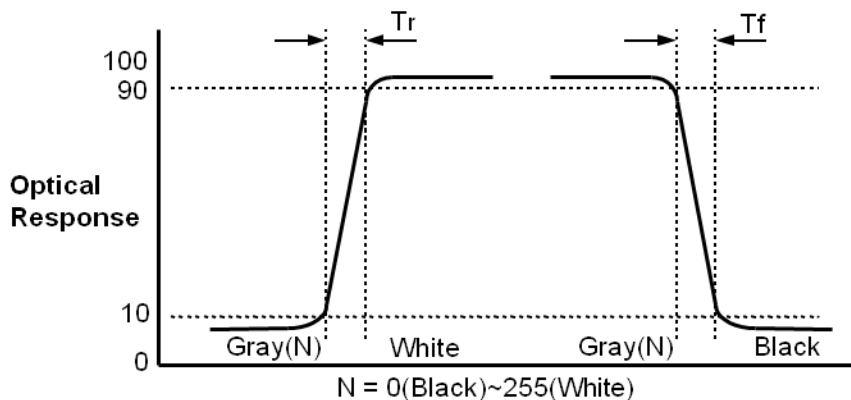

FIG. 3 Response Time

Product Specification

Dimension of viewing angle range

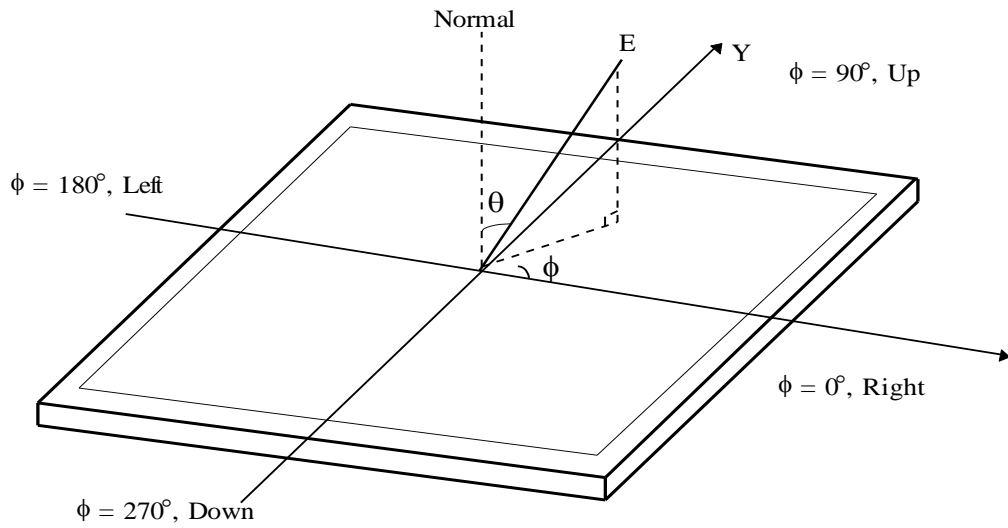

FIG. 4 Viewing Angle

Product Specification

5. Mechanical Characteristics

Table 12 provides general mechanical characteristics.

Table 12. MECHANICAL CHARACTERISTICS

| Item | Value | |
|---------------------|----------------------------|-----------|
| Outline Dimension | Horizontal | 962.0mm |
| | Vertical | 554.8mm |
| | Depth | 9.6mm |
| Bezel Area | Horizontal | 946.2mm |
| | Vertical | 534.4mm |
| Active Display Area | Horizontal | 941.184mm |
| | Vertical | 529.416mm |
| Weight | 8.3kg (Typ.) 8.7 kg (Max.) | |

notes : Please refer to a mechanical drawing in terms of tolerance at the next page.

Product Specification

[FRONT VIEW]



SET : TOP

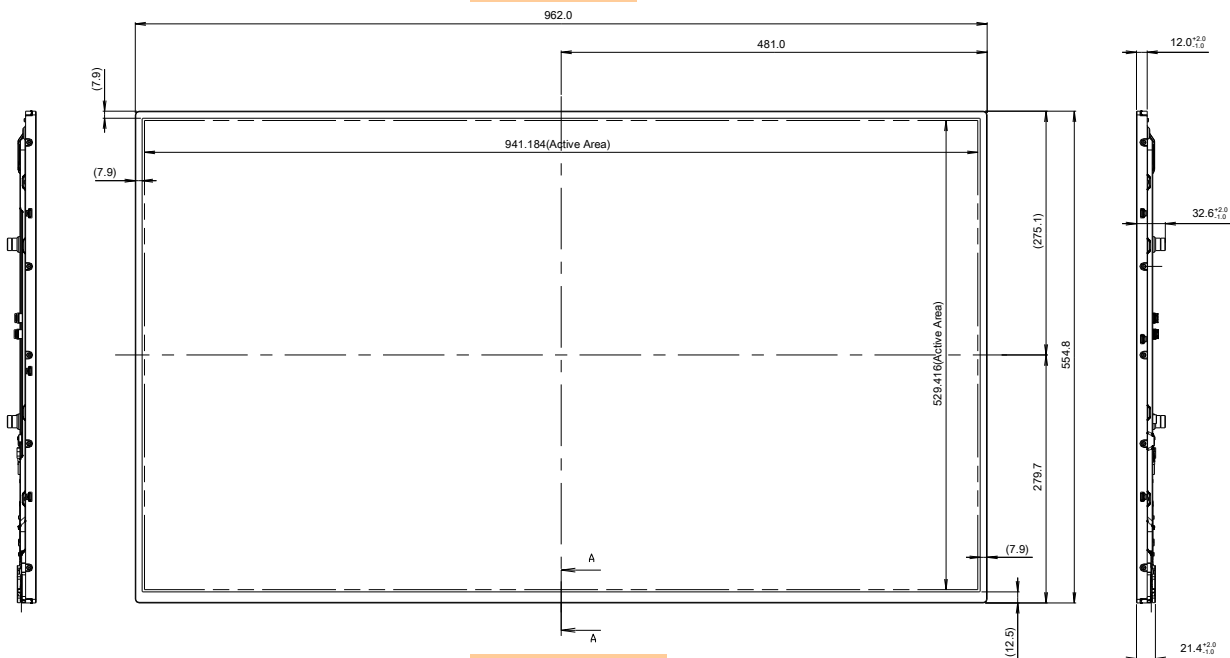

SET : DOWN

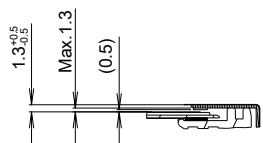
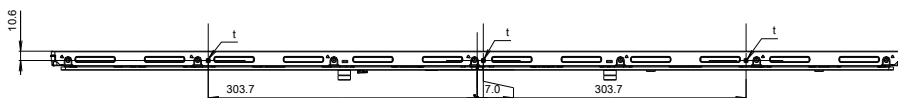

SECTION A-A

| Date | Version |
|----------|---------|
| 19.01.29 | 0.1 |
| | |
| | |
| | |

- Notes
1. Unspecified tolerance is 1.0mm
 2. Tilt and partial disposition tolerance of display area as following.
 (a) X-Direction : |A-B| ≤ 2.0mm
 (b) Y-Direction : |C-D| ≤ 2.0mm
 3. UDM depth&torque : Refer to table.
 4. Screw Head max protrusion : 1.0mm
 5. The same feature means the same dimension.
 6. Designer's approval is required before mass-production.
 7. This drawing is only preliminary data and can be changed.
 8. Version (0.1)

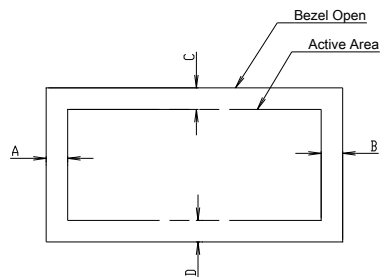

Product Specification

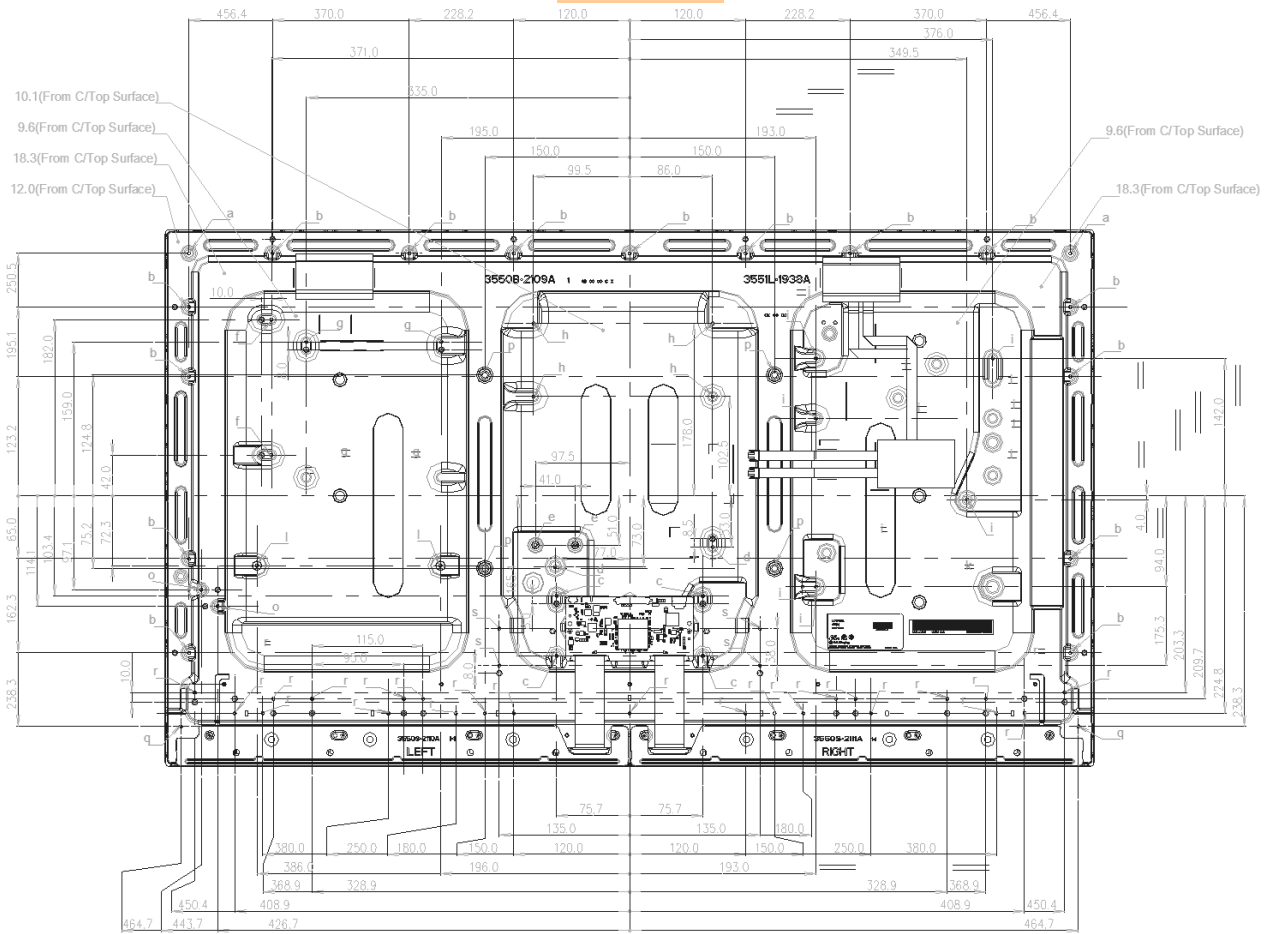
[REAR VIEW]**SET : TOP****SET : DOWN**

| Item | UDM Height | Top | Max Depth (mm) | Max.Torque (kgf.cm) | Notes |
|------|------------|------|----------------|---------------------|----------------------|
| a | 3.0 | M3.0 | 4.0 | 5.0 | 2ea |
| b | 3.0 | M3.0 | 4.0 | 5.0 | 15ea |
| c | 5.2 | M3.0 | 4.0 | 5.0 | 4ea |
| d | 6.2 | M3.0 | 5.0 | 5.0 | 2ea |
| e | 6.2 | M3.0 | 5.0 | 8.0 | 2ea |
| f | 7.2 | M3.0 | 6.0 | 5.0 | 2ea |
| g | 6.2 | M3.0 | 5.0 | 5.0 | 4ea 2ea |
| h | 6.2 | M3.0 | 5.0 | 5.0 | 4ea |
| i | 5.4 | M3.0 | 4.0 | 5.0 | 13ea 5ea |
| j | 3.7 | M3.0 | 2.5 | 5.0 | 4ea 0ea |
| k | 10.4 | M3.0 | 9.0 | 8.0 | 1ea 0ea |
| l | 13.1 | M3.0 | 12.0 | 8.0 | 2ea |
| o | 2.0 | M3.0 | 1.5 | 5.0 | 2ea |
| p | 14.3 | M6.0 | 10.0 | 15.0 | 4ea |
| q | - | M3.0 | 4.0 | 5.0 | 2ea |
| r | - | M3.0 | 4.0 | 5.0 | 25ea 23ea |
| s | - | M3.0 | 4.0 | 5.0 | 4ea |
| t | - | M3.0 | 3.0 | 5.0 | 3ea |

Product Specification

6. Reliability**Table 13. ENVIRONMENT TEST CONDITION**

| No. | Test Item | Condition |
|-----|--|--------------------------------|
| 1 | High temperature storage test | Ta= 60°C 90% 240h |
| 2 | Low temperature storage test | Ta= -20°C 240h |
| 3 | High temperature operation test | Ta= 50°C 50%RH 500h |
| 4 | Low temperature operation test | Ta= 0°C 500h |
| 5 | Humidity condition Operation | Ta= 40 °C ,90%RH |
| 6 | Altitude operating storage / shipment | 0 - 16,400 ft 0 - 40,000 ft |

Note : 1. Before and after Reliability test, LCM should be operated with normal function.

7. International Standards

7-1. Safety

- a) UL 60950-1, Underwriters Laboratories Inc.
Information Technology Equipment - Safety - Part 1 : General Requirements.
- b) CAN/CSA-C22.2 No. 60950-1-07, Canadian Standards Association.
Information Technology Equipment - Safety - Part 1 : General Requirements.
- c) EN 60950-1, European Committee for Electrotechnical Standardization (CENELEC).
Information Technology Equipment - Safety - Part 1 : General Requirements.
- d) IEC 60950-1, The International Electrotechnical Commission (IEC).
Information Technology Equipment - Safety - Part 1 : General Requirements

7-2. Environment

- a) RoHS, Directive 2011/65/EU of the European Parliament and of the council of 8 June 2011

Product Specification

8. Packing**8-1. Information of LCM Label**

a) Lot Mark

| | | | | | | | | | | | | |
|---|---|---|---|---|---|---|---|---|---|---|---|---|
| A | B | C | D | E | F | G | H | I | J | K | L | M |
|---|---|---|---|---|---|---|---|---|---|---|---|---|

A,B,C : SIZE(INCH)
E : MONTH

D : YEAR
F ~ M : SERIAL NO.

Note

1. YEAR

| | | | | | | | | | | |
|------|------|------|------|------|------|------|------|------|------|------|
| Year | 2011 | 2012 | 2013 | 2014 | 2015 | 2016 | 2017 | 2018 | 2019 | 2020 |
| Mark | A | B | C | D | E | F | G | H | J | K |

2. MONTH

| | | | | | | | | | | | | |
|-------|-----|-----|-----|-----|-----|-----|-----|-----|-----|-----|-----|-----|
| Month | Jan | Feb | Mar | Apr | May | Jun | Jul | Aug | Sep | Oct | Nov | Dec |
| Mark | 1 | 2 | 3 | 4 | 5 | 6 | 7 | 8 | 9 | A | B | C |

b) Location of Lot Mark

Serial NO. is printed on the label. The label is attached to the backside of the LCD module.
This is subject to change without prior notice.

8-2. Packing Form

a) Package quantity in one Pallet : 24 pcs

b) Pallet Size : 1300 mm(W) X 1140 mm(D) X 964 mm(H)

Product Specification

9. Precautions

Please pay attention to the followings when you use this TFT LCD module.

9-1. Mounting Precautions

- (1) You must mount a module using specified mounting holes (Details refer to the drawings).
- (2) You should consider the mounting structure so that uneven force (ex. Twisted stress, Concentrated stress) is not applied to the module. And the case on which a module is mounted should have sufficient strength so that external force is not transmitted directly to the module.
- (3) Please attach the surface transparent protective plate to the surface in order to protect the polarizer. Transparent protective plate should have sufficient strength in order to resist external force.
- (4) You should adopt radiation structure to satisfy the temperature specification.
- (5) Acetic acid type and chlorine type materials for the cover case are not desirable because the former generates corrosive gas of attacking the polarizer at high temperature and the latter causes circuit break by electro-chemical reaction.
- (6) Do not touch, push or rub the exposed polarizers with glass, tweezers or anything harder than HB pencil lead. And please do not rub with dust clothes with chemical treatment. Do not touch the surface of polarizer for bare hand or greasy cloth. (Some cosmetics are detrimental to the polarizer.)
- (7) When the surface becomes dusty, please wipe gently with absorbent cotton or other soft materials like chamois soaks with petroleum benzine. Normal-hexane is recommended for cleaning the adhesives used to attach front / rear polarizers. Do not use acetone, toluene and alcohol because they cause chemical damage to the polarizer
- (8) Wipe off saliva or water drops as soon as possible. Their long time contact with polarizer causes deformations and color fading.
- (9) Do not open the case because inside circuits do not have sufficient strength.
- (10) Touching the LED Driver might cause an electric shock and damage to LED Driver. Please always use antistatic tools when handling the LED Driver.

9-2. Operating Precautions

- (1) Response time depends on the temperature. (In lower temperature, it becomes longer.)
- (2) Brightness depends on the temperature. (In lower temperature, it becomes lower.)
And in lower temperature, response time (required time that brightness is stable after turned on) becomes longer
- (3) Be careful for condensation at sudden temperature change. Condensation makes damage to polarizer or electrical contacted parts. And after fading condensation, smear or spot will occur.
- (4) When fixed patterns are displayed for a long time, remnant image is likely to occur.
- (5) Module has high frequency circuits. Sufficient suppression to the electromagnetic interference shall be done by system manufacturers. Grounding and shielding methods may be important to minimize the interference.
- (6) Please do not give any mechanical and/or acoustical impact to LCM. Otherwise, LCM can't be operated its full characteristics perfectly.
- (7) A screw which is fastened up the steels should be a machine screw.
(if not, it can cause conductive particles and deal LCM a fatal blow)
- (8) Please do not set LCD on its edge.
- (9) The conductive material and signal cables are kept away from LED driver inductor to prevent abnormal display, sound noise and temperature rising.

9-3. Electrostatic Discharge Control

Since a module is composed of electronic circuits, it is not strong to electrostatic discharge. Make certain that treatment persons are connected to ground through wrist band etc. And don't touch interface pin directly.

9-4. Precautions for Strong Light Exposure

Strong light exposure causes degradation of polarizer and color filter.

9-5. Storage

When storing modules as spares for a long time, the following precautions are necessary.

- (1) Store them in a dark place. Do not expose the module to sunlight or fluorescent light. Keep the temperature between 5°C and 35°C at normal humidity.
- (2) The polarizer surface should not come in contact with any other object.
It is recommended that they be stored in the container in which they were shipped.
- (3) Storage condition is guaranteed under packing conditions.
- (4) The phase transition of Liquid Crystal in the condition of the low or high storage temperature will be recovered when the LCD module returns to the normal condition.

9-6. Handling Precautions for Protection Film

- (1) The protection film is attached to the bezel with a small masking tape.
When the protection film is peeled off, static electricity is generated between the film and polarizer.
This should be peeled off slowly and carefully by people who are electrically grounded and with well ion-blown equipment or in such a condition, etc.
- (2) When the module with protection film attached is stored for a long time, sometimes there remains a very small amount of glue still on the bezel after the protection film is peeled off.
- (3) You can remove the glue easily. When the glue remains on the bezel surface or its vestige is recognized, please wipe them off with absorbent cotton waste or other soft material like chamois soaked with normal-hexane.

9-7. Appropriate Condition for Public Display

- Generally large-sized LCD modules are designed for consumer applications (TV). Accordingly, a long-term display like in Public Display (PD) application, can cause uneven display including image sticking. To optimize module's lifetime and function, several operating usages are required.

1. Normal operating condition

- Temperature: 0 ~ 40 °C
 - Operating Ambient Humidity : 10 ~ 90 %
 - Display pattern: dynamic pattern (Real display)
- Note) Long-term static display can cause image sticking.

2. Operating usages under abnormal condition

a. Ambient condition

- Well-ventilated place is recommended to set up PD system.

b. Power and screen save

- Periodical power-off or screen save is needed after long-term display.

3. Operating usages to protect against image sticking due to long-term static display

a. Suitable operating time: under 24 hours a day.

b. Static information display recommended to use with moving image.

- Cycling display between 5 minutes' information(static) display and 10 seconds' moving image.

c. Background and character (image) color change

- Use different colors for background and character, respectively.
- Change colors themselves periodically.

d. Avoid combination of background and character with large different luminance.

1) Abnormal condition just means conditions except normal condition.

2) Black image or moving image is strongly recommended as a screen save.

4. Lifetime in this spec. is guaranteed only when PD is used according to operating usages.

Product Specification

APPENDIX-I

■ Pallet Ass'y

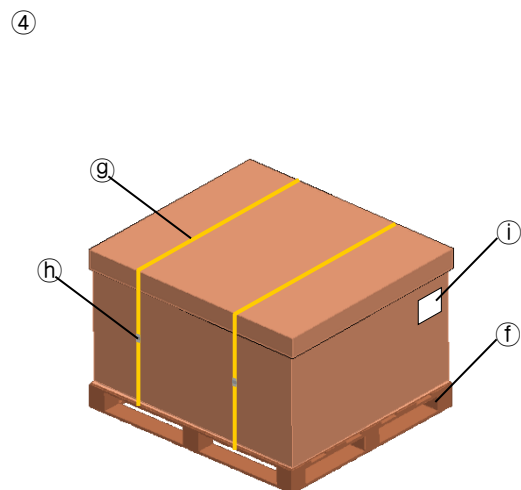
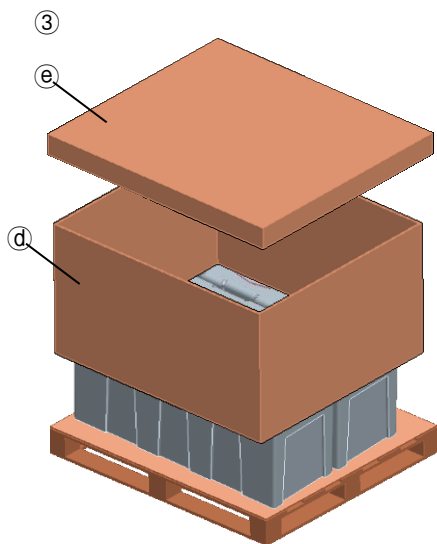
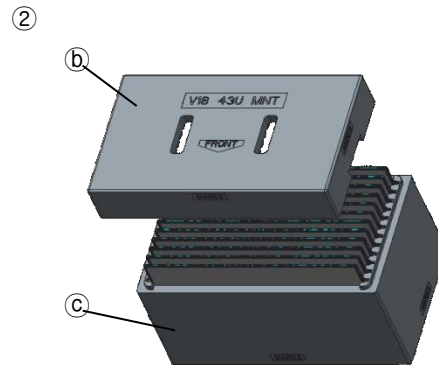
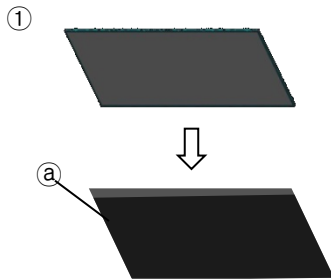

| No. | Description | Material |
|-----|----------------|-------------|
| (a) | BAG | AL |
| (b) | PackingTop | EPS |
| (c) | Packing,Bottom | EPS |
| (d) | Angle Packing | Double Wall |
| (e) | Angle Cover | Single Wall |
| (f) | Pallet | Plywood |
| (g) | Band | PP |
| (h) | Clip | Steel |
| (i) | Label | Paper |

Product Specification

APPENDIX- II-1

■ LCM Label

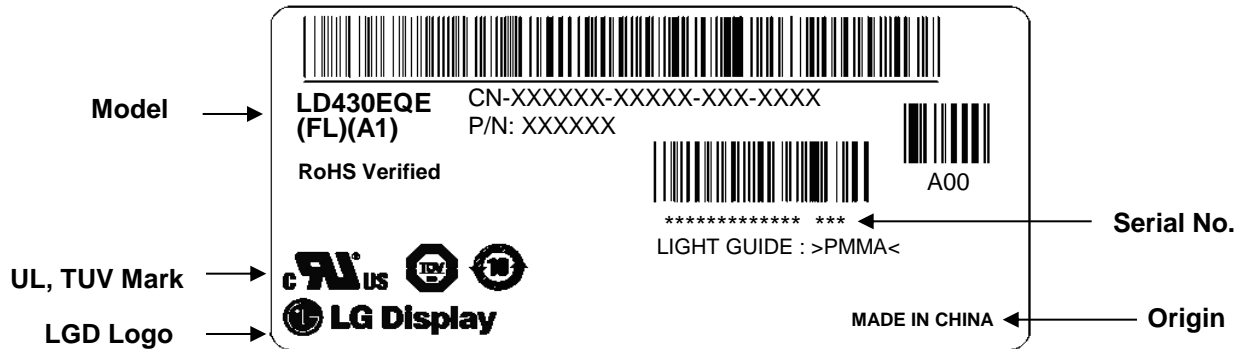

Product Specification

APPENDIX- II-2

■ Pallet Label

| | | |
|--|------------------|----------------------|
| LD430EQE | | FLA1 |
| XXXXX | | ZB |
| 24 PCS | LOT/MM-DD | |
| MADE IN CHINA | | RoHS Verified |
|  ***** | | |

Product Specification

APPENDIX- III

■ Required signal assignment for Flat Link (Thine : THCv216) Transmitter

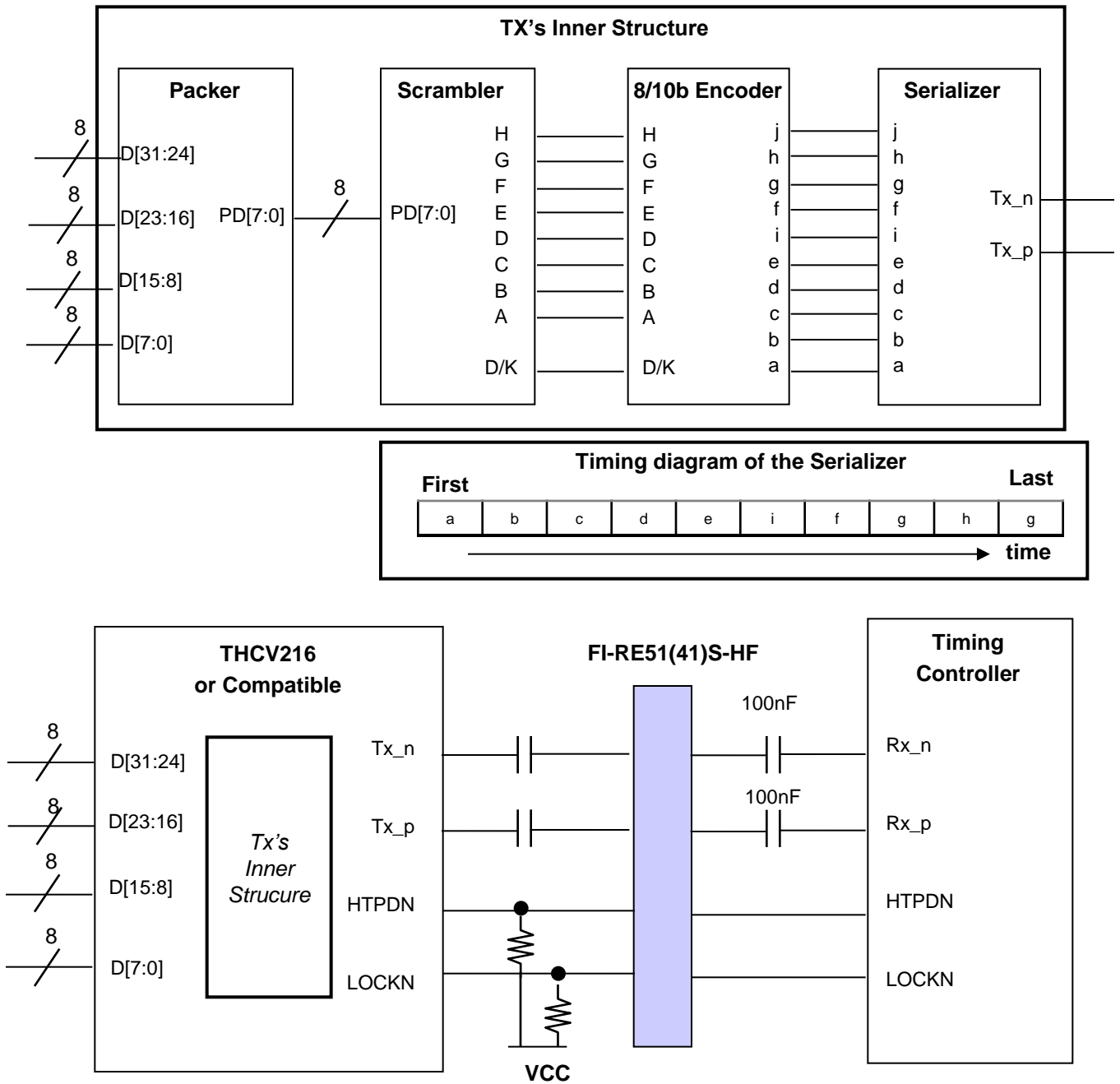

- notes: 1. The LCD module uses a 100 nF capacitor on positive and negative lines of each receiver input.
 2. Refer to Vx1 Transmitter Data Sheet for detail descriptions. (THCV216 or Compatible)
 3. About Module connector pin configuration, Please refer to the Page 8~9.

APPENDIX- IV-1

■ Option Pin Circuit Block Diagram

1) Circuit Block Diagram of Data format Selection pin

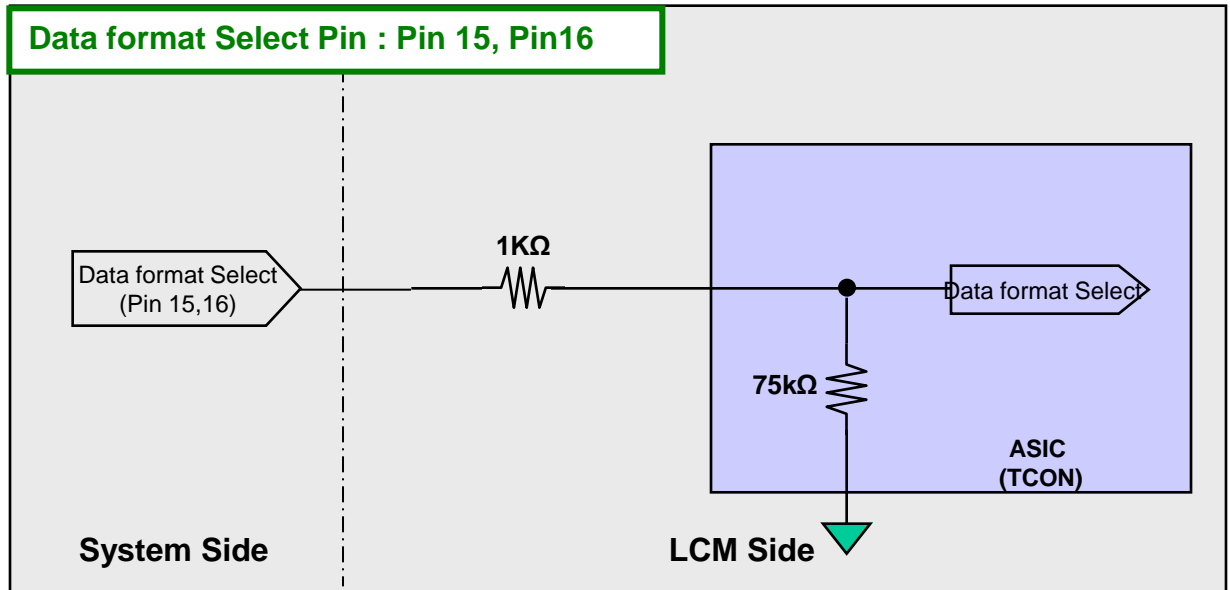

2) Circuit Block Diagram of Bit Selection pin

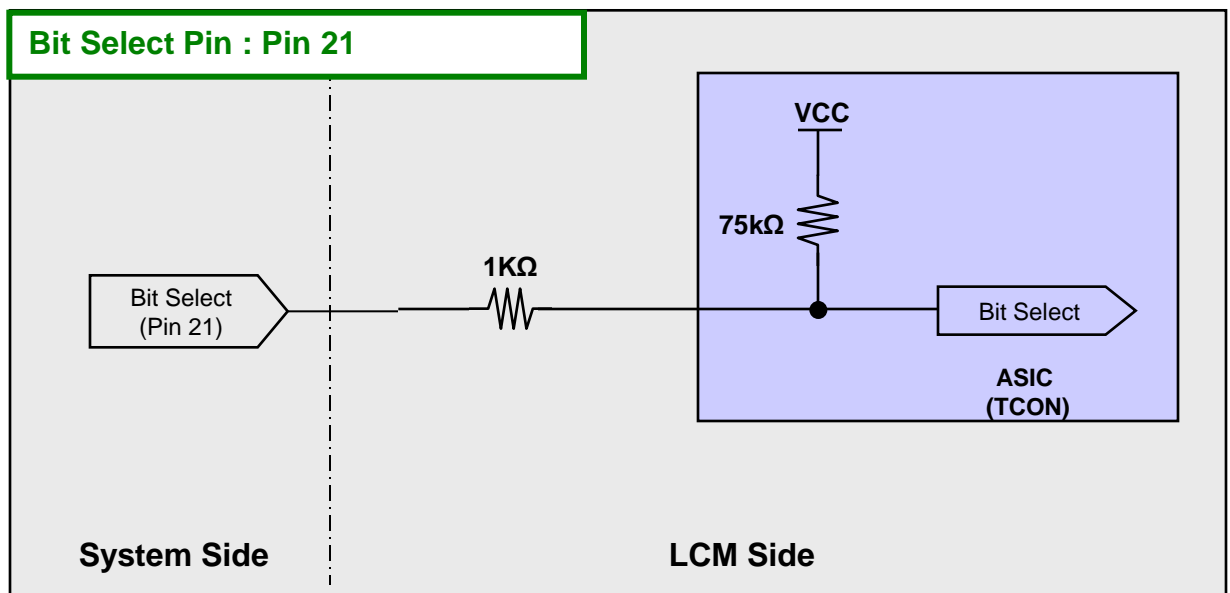

APPENDIX- IV-2

■ Option Pin Circuit Block Diagram

3) Circuit Block Diagram of AGP Selection pin

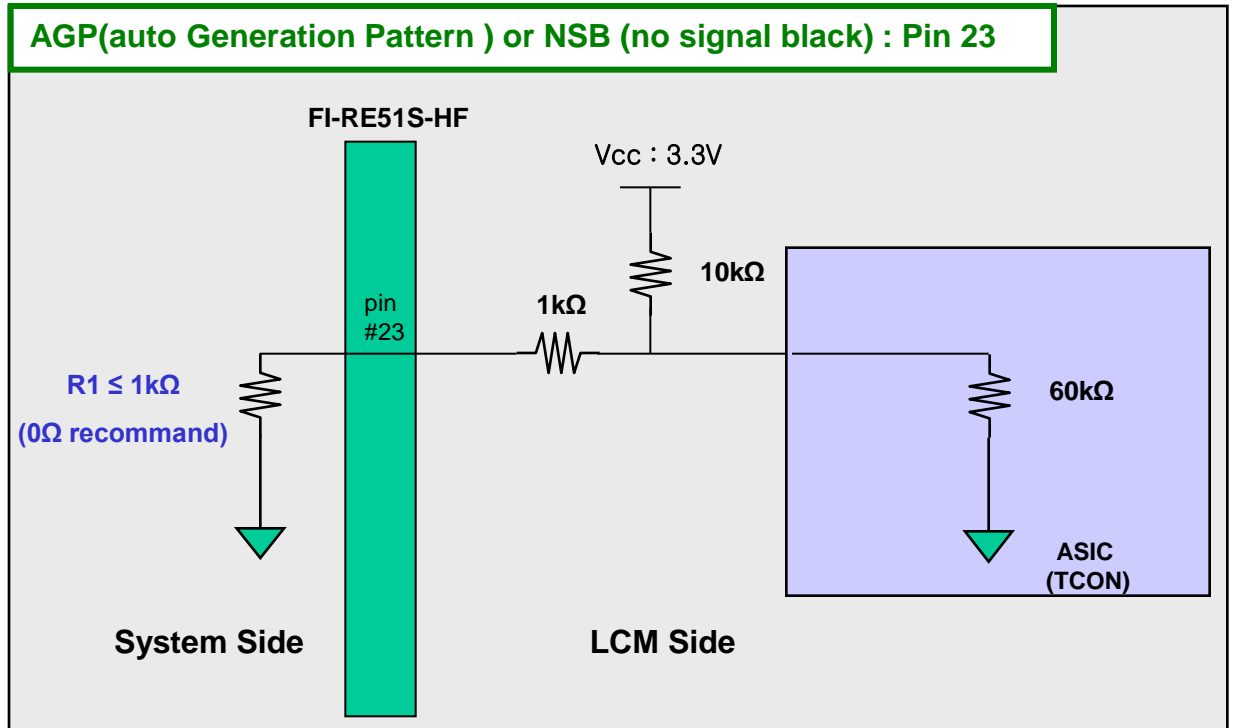

Product Specification

APPENDIX- VI

■ input mode of pixel data

| Mode 1 : Non-Division | | | | Mode 2 : 2 Division | | | |
|-----------------------|----------------------|----------------------|-------|---------------------|----------------------|----------------------|-------|
| | | | | | | | |
| Lane | 1 st Data | 2 nd Data | Data# | Lane | 1 st Data | 2 nd Data | Data# |
| Lane0 | 1 | 9 | 3833 | Lane0 | 1 | 5 | 1917 |
| Lane1 | 2 | 10 | 3834 | Lane1 | 2 | 6 | 1918 |
| Lane2 | 3 | 11 | 3835 | Lane2 | 3 | 7 | 1919 |
| Lane3 | 4 | 12 | 3836 | Lane3 | 4 | 8 | 1920 |
| Lane4 | 5 | 13 | 3837 | Lane4 | 1921 | 1925 | 3837 |
| Lane5 | 6 | 14 | 3838 | Lane5 | 1922 | 1926 | 3838 |
| Lane6 | 7 | 15 | 3839 | Lane6 | 1923 | 1927 | 3839 |
| Lane7 | 8 | 16 | 3840 | Lane7 | 1924 | 1928 | 3840 |

Product Specification

APPENDIX- VII

■ LED Array Electrical Spec

(Ta=25±2℃)

| Item | Symbol | | Min | Typ | Max | Unit |
|-------------------------|--------|---------|-------|-------|-------|------|
| Array Operating Voltage | Vf | IF=55mA | 151.1 | 160.1 | 170.1 | V |
| | ΔVf | IF=55mA | | | 1.7 | V |

*Typ. If=55[mA] : This value is determined by the specific LED current (55mA per LED)

■ Forward Current vs. Forward Voltage

(Ta = 25℃)

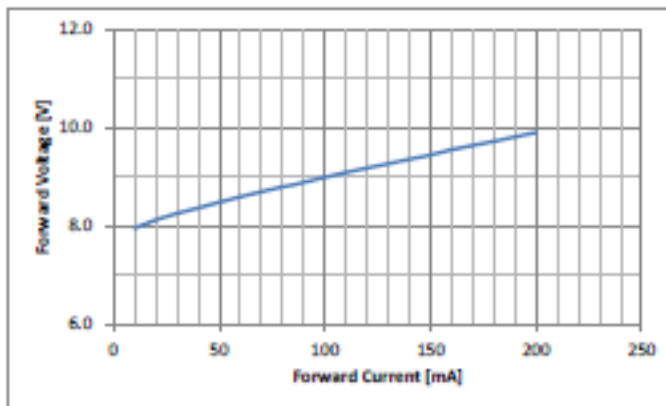

■ Ambient Temperature vs. Forward Voltage

