

# Model Name: P215HAN02.0

Issue Date : 2020/10/30

( ) Preliminary Specifications

(\* ) Final Specifications

Customer Signature	Date	AUO	Date
Approved By  _____		Approval By PM Director CT Wu  _____	
Note		Reviewed By RD Director Eugene.CC.Chen  _____	
		Reviewed By Project Leader Amelia Huang  _____	
		Prepared By PM Sophie Teng  _____	

## Contents

<b>1. General Description</b> .....	6
1.1. Display Characteristics.....	6
1.2. Optical Characteristics.....	7
1.3. Mechanical Characteristics.....	11
1.3.1. Placement Suggestions.....	11
1.3.2. Mechanical Characteristics.....	12
1.3.3. Absolute Maximum Ratings.....	13
<b>2. Electrical Specification</b> .....	14
2.1. Block Diagram.....	14
2.2. Interface Connection.....	15
2.2.1. Connector Type.....	15
2.2.2. Connector Pin Assignment.....	15
2.3. Electrical Characteristics.....	17
2.3.1. Absolute Maximum Rating.....	17
2.3.2. Recommended Operating Condition.....	17
2.4. Signal Characteristics.....	19
2.4.1. LCD Pixel Format.....	19
2.4.2. LVDS Data Format.....	19
2.4.3. Color versus Input Data.....	20
2.4.4. LVDS Specification.....	20
2.4.5. Input Timing Specification.....	23
2.4.6. Input Timing Diagram.....	24
2.5. Power ON/OFF Sequence.....	25
<b>3. Backlight Unit</b> .....	26
3.1. Block Diagram.....	26
3.2. Interface Connection.....	27
3.2.1. Connector Type.....	27
3.2.2. Connector Pin Assignment.....	28
3.3. Electrical Characteristics.....	29
3.3.1. Absolute Maximum Rating.....	29
3.3.2. Recommended Operating Condition.....	29
<b>4. Reliability Test Items</b> .....	31
<b>5. International Standard</b> .....	32
5.1. Safety.....	32
5.2. EMC.....	32
<b>6. Packing</b> .....	33
6.1. Definition of Label.....	33
6.2. Packing Methods.....	34

<b>7. Precautions</b> .....	<b>36</b>
7.1. Mounting Precautions.....	36
7.2. Operating Precautions.....	36
7.3. Operating Condition for Public Information Display .....	37
7.4. Electrostatic Discharge Control .....	37
7.5. Precautions for Strong Light Exposure .....	38
7.6. Storage .....	38
7.7. Handling Precautions for Protection Film .....	38

# Record of Revision

Version	Date	Page	Description																																																																						
1.0	2017/07/25		First release																																																																						
1.1	2017/08/03	35	<p>Pallet and Shipment Information: box, packing box and pallet after packing dimension updated.</p> <table border="1"> <thead> <tr> <th>Item</th> <th>Qty</th> <th>Dimension</th> <th>Weight(kg)</th> <th>Remark</th> </tr> </thead> <tbody> <tr> <td>1- Panel</td> <td>1-</td> <td>501 1mm(H) × 202 2mm(V) × 16 302mm</td> <td>2 1-</td> <td>Note 1-</td> </tr> <tr> <td>2- Cushion</td> <td>1-</td> <td>-</td> <td>0 55-</td> <td>-</td> </tr> <tr> <td>3- Box</td> <td>1-</td> <td>5562 2mm × 2020 0mm × 375 0mm</td> <td>1 40-</td> <td>without Panel &amp; cushion Note 1-</td> </tr> <tr> <td>4- Packing Box</td> <td>8 pcs/Box</td> <td>5562 2mm × 2020 0mm × 375 0mm</td> <td>18 75-</td> <td>with panel &amp; cushion Note 1-</td> </tr> <tr> <td>5- Pallet</td> <td>1-</td> <td>1150 0mm × 910 0mm × 132 0mm</td> <td>13 8-</td> <td>Note 1-</td> </tr> <tr> <td>6- Pallet after Packing 18 boxes/pallet</td> <td>1-</td> <td>1150 0mm × 910 0mm × 132 0mm</td> <td>351 3-</td> <td>Note 1-</td> </tr> </tbody> </table> <table border="1"> <thead> <tr> <th>Item</th> <th>Qty</th> <th>Dimension</th> <th>Weight(kg)</th> <th>Remark</th> </tr> </thead> <tbody> <tr> <td>1- Panel</td> <td>1-</td> <td>501 1mm(H) × 202 2mm(V) × 16 302mm</td> <td>2 1-</td> <td>Note 1-</td> </tr> <tr> <td>2- Cushion</td> <td>1-</td> <td>-</td> <td>0 55-</td> <td>-</td> </tr> <tr> <td>3- Box</td> <td>1-</td> <td>5562 2mm × 2020 0mm × 375 0mm</td> <td>1 40-</td> <td>without Panel &amp; cushion Note 1-</td> </tr> <tr> <td>4- Packing Box</td> <td>8 pcs/Box</td> <td>554 0mm × 200 00mm × 393 0mm</td> <td>18 75-</td> <td>with panel &amp; cushion Note 1-</td> </tr> <tr> <td>5- Pallet</td> <td>1-</td> <td>1150 0mm × 910 0mm × 132 0mm</td> <td>13 8-</td> <td>Note 1-</td> </tr> <tr> <td>6- Pallet after Packing 18 boxes/pallet</td> <td>1-</td> <td>1150 0mm × 910 0mm × 131 0mm</td> <td>351 3-</td> <td>Note 1-</td> </tr> </tbody> </table>	Item	Qty	Dimension	Weight(kg)	Remark	1- Panel	1-	501 1mm(H) × 202 2mm(V) × 16 302mm	2 1-	Note 1-	2- Cushion	1-	-	0 55-	-	3- Box	1-	5562 2mm × 2020 0mm × 375 0mm	1 40-	without Panel & cushion Note 1-	4- Packing Box	8 pcs/Box	5562 2mm × 2020 0mm × 375 0mm	18 75-	with panel & cushion Note 1-	5- Pallet	1-	1150 0mm × 910 0mm × 132 0mm	13 8-	Note 1-	6- Pallet after Packing 18 boxes/pallet	1-	1150 0mm × 910 0mm × 132 0mm	351 3-	Note 1-	Item	Qty	Dimension	Weight(kg)	Remark	1- Panel	1-	501 1mm(H) × 202 2mm(V) × 16 302mm	2 1-	Note 1-	2- Cushion	1-	-	0 55-	-	3- Box	1-	5562 2mm × 2020 0mm × 375 0mm	1 40-	without Panel & cushion Note 1-	4- Packing Box	8 pcs/Box	554 0mm × 200 00mm × 393 0mm	18 75-	with panel & cushion Note 1-	5- Pallet	1-	1150 0mm × 910 0mm × 132 0mm	13 8-	Note 1-	6- Pallet after Packing 18 boxes/pallet	1-	1150 0mm × 910 0mm × 131 0mm	351 3-	Note 1-
Item	Qty	Dimension	Weight(kg)	Remark																																																																					
1- Panel	1-	501 1mm(H) × 202 2mm(V) × 16 302mm	2 1-	Note 1-																																																																					
2- Cushion	1-	-	0 55-	-																																																																					
3- Box	1-	5562 2mm × 2020 0mm × 375 0mm	1 40-	without Panel & cushion Note 1-																																																																					
4- Packing Box	8 pcs/Box	5562 2mm × 2020 0mm × 375 0mm	18 75-	with panel & cushion Note 1-																																																																					
5- Pallet	1-	1150 0mm × 910 0mm × 132 0mm	13 8-	Note 1-																																																																					
6- Pallet after Packing 18 boxes/pallet	1-	1150 0mm × 910 0mm × 132 0mm	351 3-	Note 1-																																																																					
Item	Qty	Dimension	Weight(kg)	Remark																																																																					
1- Panel	1-	501 1mm(H) × 202 2mm(V) × 16 302mm	2 1-	Note 1-																																																																					
2- Cushion	1-	-	0 55-	-																																																																					
3- Box	1-	5562 2mm × 2020 0mm × 375 0mm	1 40-	without Panel & cushion Note 1-																																																																					
4- Packing Box	8 pcs/Box	554 0mm × 200 00mm × 393 0mm	18 75-	with panel & cushion Note 1-																																																																					
5- Pallet	1-	1150 0mm × 910 0mm × 132 0mm	13 8-	Note 1-																																																																					
6- Pallet after Packing 18 boxes/pallet	1-	1150 0mm × 910 0mm × 131 0mm	351 3-	Note 1-																																																																					
1.2	2017/08/25	5	Added note1 with pixel pitch in display characteristics table.																																																																						
1.2	2017/08/25	all	Updated note sequence.																																																																						
1.2	2017/08/25	28	Added LED string current: Max 51mA.																																																																						
1.2	2017/08/25	30	<p>Reliability test items: Updated item 5, 6(Vibration/drop test (With carton)) test condition and add item 7, 8 (Vibration/Shock test (non-operation)).</p> <table border="1"> <thead> <tr> <th>Test Item</th> <th>Qty</th> <th>Condition</th> </tr> </thead> <tbody> <tr> <td>1. High temperature storage test.</td> <td>3.</td> <td>50°C, 500hrs.</td> </tr> <tr> <td>2. Low temperature storage test.</td> <td>3.</td> <td>0°C, 500hrs.</td> </tr> <tr> <td>3. High temperature operation test.</td> <td>3.</td> <td>50°C, 500hrs.</td> </tr> <tr> <td>4. Low temperature operation test.</td> <td>3.</td> <td>0°C, 500hrs.</td> </tr> <tr> <td>5. Vibration test (With carton).</td> <td>1(PKG)</td> <td>Random wave(1.045rms 2-200Hz). Duration: X, Y, Z 20min per axes.</td> </tr> <tr> <td>6. Drop test (With carton).</td> <td>1(PKG)</td> <td>Height: 25.4 cm. Direction: Only bottom flat twice. (ASTM D4168a).</td> </tr> </tbody> </table> <table border="1"> <thead> <tr> <th>Test Item</th> <th>Qty</th> <th>Condition</th> </tr> </thead> <tbody> <tr> <td>1. High temperature storage test.</td> <td>3.</td> <td>50°C, 500hrs.</td> </tr> <tr> <td>2. Low temperature storage test.</td> <td>3.</td> <td>0°C, 500hrs.</td> </tr> <tr> <td>3. High temperature operation test.</td> <td>3.</td> <td>50°C, 500hrs.</td> </tr> <tr> <td>4. Low temperature operation test.</td> <td>3.</td> <td>0°C, 500hrs.</td> </tr> <tr> <td>5. Vibration test (With carton).</td> <td>1CTM/PCS</td> <td>Acceleration: 1.5G RMS Wave: Random Frequency: 2-200 Hz. Setup: 30 Minutes each Axis (X, Y, Z).</td> </tr> <tr> <td>6. Drop test (With carton).</td> <td>1CTM/PCS</td> <td>Height: 61.7 cm. Direction: 1 Corner (Edge-to-Edge) 4 Times. (ASTM D4168a).</td> </tr> <tr> <td>7. Vibration test (non-operation).</td> <td>3.</td> <td>Random wave condition. Vibration level: 1.0G RMS. Duration: 1.5 Hours. K-axis, Vertical, 30min. F-axis, Vertical, 30min. Z-axis, Vertical, 30min. (ASTM D4168a).</td> </tr> <tr> <td>8. Shock test (non-operation).</td> <td>3.</td> <td>500, 20ms at X, Y, Z axis. Direction: Half sine wave. (Direction: One time each direction).</td> </tr> </tbody> </table>	Test Item	Qty	Condition	1. High temperature storage test.	3.	50°C, 500hrs.	2. Low temperature storage test.	3.	0°C, 500hrs.	3. High temperature operation test.	3.	50°C, 500hrs.	4. Low temperature operation test.	3.	0°C, 500hrs.	5. Vibration test (With carton).	1(PKG)	Random wave(1.045rms 2-200Hz). Duration: X, Y, Z 20min per axes.	6. Drop test (With carton).	1(PKG)	Height: 25.4 cm. Direction: Only bottom flat twice. (ASTM D4168a).	Test Item	Qty	Condition	1. High temperature storage test.	3.	50°C, 500hrs.	2. Low temperature storage test.	3.	0°C, 500hrs.	3. High temperature operation test.	3.	50°C, 500hrs.	4. Low temperature operation test.	3.	0°C, 500hrs.	5. Vibration test (With carton).	1CTM/PCS	Acceleration: 1.5G RMS Wave: Random Frequency: 2-200 Hz. Setup: 30 Minutes each Axis (X, Y, Z).	6. Drop test (With carton).	1CTM/PCS	Height: 61.7 cm. Direction: 1 Corner (Edge-to-Edge) 4 Times. (ASTM D4168a).	7. Vibration test (non-operation).	3.	Random wave condition. Vibration level: 1.0G RMS. Duration: 1.5 Hours. K-axis, Vertical, 30min. F-axis, Vertical, 30min. Z-axis, Vertical, 30min. (ASTM D4168a).	8. Shock test (non-operation).	3.	500, 20ms at X, Y, Z axis. Direction: Half sine wave. (Direction: One time each direction).																						
Test Item	Qty	Condition																																																																							
1. High temperature storage test.	3.	50°C, 500hrs.																																																																							
2. Low temperature storage test.	3.	0°C, 500hrs.																																																																							
3. High temperature operation test.	3.	50°C, 500hrs.																																																																							
4. Low temperature operation test.	3.	0°C, 500hrs.																																																																							
5. Vibration test (With carton).	1(PKG)	Random wave(1.045rms 2-200Hz). Duration: X, Y, Z 20min per axes.																																																																							
6. Drop test (With carton).	1(PKG)	Height: 25.4 cm. Direction: Only bottom flat twice. (ASTM D4168a).																																																																							
Test Item	Qty	Condition																																																																							
1. High temperature storage test.	3.	50°C, 500hrs.																																																																							
2. Low temperature storage test.	3.	0°C, 500hrs.																																																																							
3. High temperature operation test.	3.	50°C, 500hrs.																																																																							
4. Low temperature operation test.	3.	0°C, 500hrs.																																																																							
5. Vibration test (With carton).	1CTM/PCS	Acceleration: 1.5G RMS Wave: Random Frequency: 2-200 Hz. Setup: 30 Minutes each Axis (X, Y, Z).																																																																							
6. Drop test (With carton).	1CTM/PCS	Height: 61.7 cm. Direction: 1 Corner (Edge-to-Edge) 4 Times. (ASTM D4168a).																																																																							
7. Vibration test (non-operation).	3.	Random wave condition. Vibration level: 1.0G RMS. Duration: 1.5 Hours. K-axis, Vertical, 30min. F-axis, Vertical, 30min. Z-axis, Vertical, 30min. (ASTM D4168a).																																																																							
8. Shock test (non-operation).	3.	500, 20ms at X, Y, Z axis. Direction: Half sine wave. (Direction: One time each direction).																																																																							
1.2	2017/08/25	36	Deleted 7.3 (2) a(* The moving picture can be allowed for 24 hours a day)																																																																						
1.3	2017/09/04	5	<p>Modified prim pitch unit.</p> <p>A. Prism film pitch: 50mm. → Prism film pitch: 50um.</p>																																																																						
1.4	2017/12/11	6	Added "High Tni (110°C) liquid crystal is also applied on this model to enhance the sunlight readability" in General Description.																																																																						
1.4	2017/12/11	12	<p>Modified the label position.</p>																																																																						
1.4	2017/12/11	31	<p>Modified reliability test items.</p> <p>A. Item5 Vibration test (With carton): Q'ty_1CNT/8PCS → 1CNT/7PCS.</p> <p>B. Item6 Drop test (With carton): Q'ty_1CNT/8PCS → 1CNT/7PCS. Condition_ Height 45.7cm → 61cm.</p>																																																																						

1.4	2017/12/11	34	Changed the packing method. A. Packing material: Anti-static bag → Aluminum foil bag B. Packing Q'ty/box: 8pcs/box → 7pcs/box.
1.4	2017/12/11	35	Modified pallet and shipment Information. A. Packing box: Q'ty_8pcs/box → 7pcs/box / Weight_18.75kg →16.57kg B. Pallet after packing: Weight_351.3kg →321.1kg.
1.5	2018/02/27	12	Modified the screw hole of SB cover.
1.6	2018/03/07	6	Changed the prism angle from 0D/90D to 10D/100D.
1.7	2018/09/13	34 37	Modified the tape numbers from 2 to 4 Updated the suitable operating time to 24 hours a day
1.8	2018/10/01	12	Modified 2D drawing
1.9	2018/11/08	33 34	Modified packing label Modified the drawing of EPE Cushion
2.0	2019/1/17	7 29	Modified the test condition for optical characteristics → IS=47mA Modified the LED string current as max. 51mA @ 100% duty ratio
2.1	2019/3/7	12	Modified the vendor code in 2D drawing
2.2	2019/5/17	17 29	Modified LED Life Time from 50,000 to 70,000 hours.
2.3	2019/6/11	13 31 37	Modified operating temperature to -20~50 degree Modified low temperature operation test condition to -20 degree Modified operating temperature to -20~50 degree
2.4	2019/8/13	6	Modified description of High Tni liquid crystal
2.5	2020/10/30	33	Update packing information based on Label EC

# 1. General Description

This specification applies to the 21.5 inch wide Color a-Si TFT-LCD Module P215HAN02.0. The display supports the Full HD - 1920(H) x 1080(V) screen format and 16.7M colors (8 bits RGB data input). The input interface is Dual channel LVDS and this module doesn't contain a driver board for backlights. Special material applied into this model is:

1. Liquid crystal: High Tni LC(110°C).

## \* General Information

### 1.1. Display Characteristics

The following items are characteristics summary on the table under 25°C condition:

ITEMS	Unit	SPECIFICATIONS	Note
Screen Diagonal	[mm]	546.86 (21.5")	
Active Area	[mm]	476.064 (H) x 267.786 (V)	
Pixels H x V	-	1920(x3) x 1080	
Pixel Pitch	[um]	247.95 (per one triad) x247.95	Note1
Pixel Arrangement	-	R.G.B. Vertical Stripe	
Display Mode	-	AHVA, normally Black	
White Luminance (Center)	[cd/m2]	1500 (Typ.)	
Contrast Ratio	-	1000 (Typ.)	
Response Time	[msec]	25 (Typ., G/G)	
Power Consumption (LCD Module+Backlight unit)	[Watt]	38.1 (Typ.) LCD module : PDD (Typ.)= 2.3@White pattern,Fv=60Hz Backlight unit : P <sub>BLU</sub> (Typ.) =35.8@Is= 47 mA	
Weight	[Grams]	2.1 Kg	
Outline Dimension	[mm]	501.1(H) x 292.2(V) x16.12 (D) Typ	
Electrical Interface	-	Dual channel LVDS , 8-bit RGB data input	
Support Color	-	16.7M colors	
Surface Treatment	-	Anti-Glare, 3H	Haze=25%
Rotate Function		Unachievable	Note 2
Display Orientation		Portrait/Landscape Enabled	Note 3

**Note1:** If this model will be used for touch application, please refer to the following parameters in order to avoid the light interference. (ex. Moire)

- A. Pixel pitch: 247.95um.
- B. Prism film pitch: 50um.
- C. Prism film angle: 10 and 100 degree.

**Note 2:** Rotate Function refers to LCD display could be able to rotate. This function does not work in this model.

**Note 3:** Please refer to 1.3.1 Placement Suggestions.

## 1.2. Optical Characteristics

The optical characteristics are measured on the following test condition.

Test Condition:

1. Equipment setup: Please refer to Note 1-1.
2. Panel Lighting time: 30 minutes
3. VDD=5.0V, Fv=60Hz, Is=47mA, Ta=25°C

Symbol	Description		Min.	Typ.	Max.	Unit	Remark	
Lw	White Luminance (Center of screen)		1200	1500	-	[cd/m <sup>2</sup> ]	Note 1-1 By SR-3	
Luni	Luminance Uniformity (9 points)		75	80	-	[%]	Note 1-2 By SR-3	
CR	Contrast Ratio (Center of screen)		600	1000	-	-	Note 1-3 By SR-3	
θR	Horizontal Viewing Angle (CR=10)	Right	75	89	-	[degree]	Note 1-4 By SR-3	
θL		Left	75	89	-			
ΦH	Vertical Viewing Angle (CR=10)	Up	75	89	-			
ΦL		Down	75	89	-			
θR	Horizontal Viewing Angle (CR=5)	Right	75	89	-			
θL		Left	75	89	-			
ΦH	Vertical Viewing Angle (CR=5)	Up	75	89	-			
ΦL		Down	75	89	-			
T <sub>GTG</sub>	Response Time	Gray to Gray	-	25	-	[msec]	Note 1-5 By TRD-100	
Rx	Color Coordinates (CIE 1931)		Red x	0.615	0.645	0.675	-	By SR-3
Ry			Red y	0.308	0.338	0.368		
Gx			Green x	0.290	0.320	0.350		
Gy			Green y	0.590	0.620	0.650		
Bx			Blue x	0.120	0.150	0.180		
By			Blue y	0.025	0.055	0.085		
Wx			White x	0.283	0.313	0.343		
Wy			White y	0.299	0.329	0.359		
NTSC Area Ratio				72		[%]	By SR-3	
CT	Crosstalk		-	-	1.5	[%]	Note 1-6 By SR-3	

**Note 1-1:** Equipment setup :

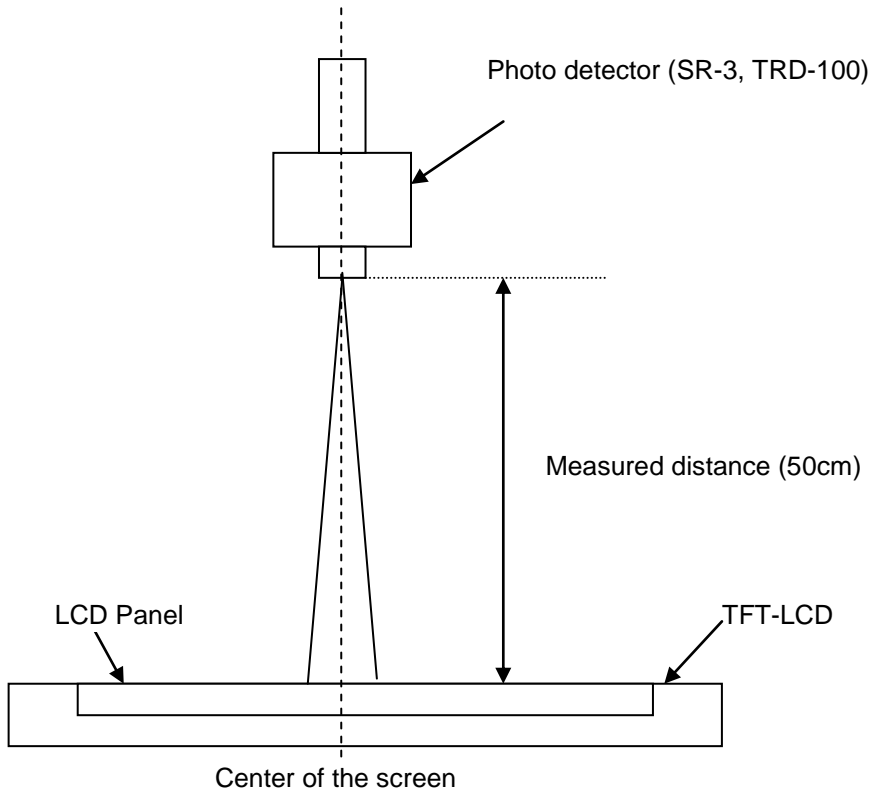

**Note 1-2:** Luminance Uniformity Measurement

**Definition:**

$$\text{Luminance Uniformity } y = \frac{\text{Minimum Luminance of 9 Points (P1 ~ P9)}}{\text{Maximum Luminance of 9 Points (P1 ~ P9)}}$$

a. Test pattern: White Pattern

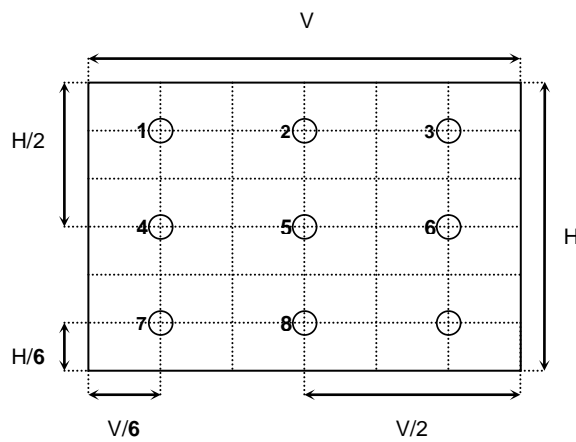



**Note 1-3: Contrast Ratio Measurement**

**Definition:**

$$\text{Contrast Ratio} = \frac{\text{Luminance of White pattern}}{\text{Luminance of Black pattern}}$$

- a. Measured position: Center of screen (P5) & perpendicular to the screen ( $\theta = \Phi = 0^\circ$ )

**Note 1-4: Viewing angle measurement**

**Definition:** The angle at which the contrast ratio is greater than 10 & 5 .

- a. Horizontal view angle: Divide to left & right ( $\theta_L$  &  $\theta_R$ )

Vertical view angle: Divide to up & down ( $\Phi_H$  &  $\Phi_L$ )

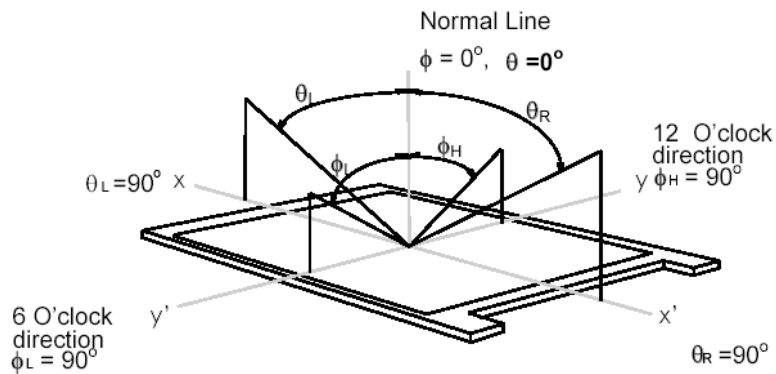

**Note 1-5: Response time measurement**

The output signals of photo detector are measured when the input signals are changed from “Gray level A” to “Gray level B” (falling time,  $T_f$ ), and from “Gray level B” to “Gray level A” (rising time,  $T_r$ ), respectively. The response time is interval between the 10% and 90% of optical response.

The gray to gray response time is defined as the following table.

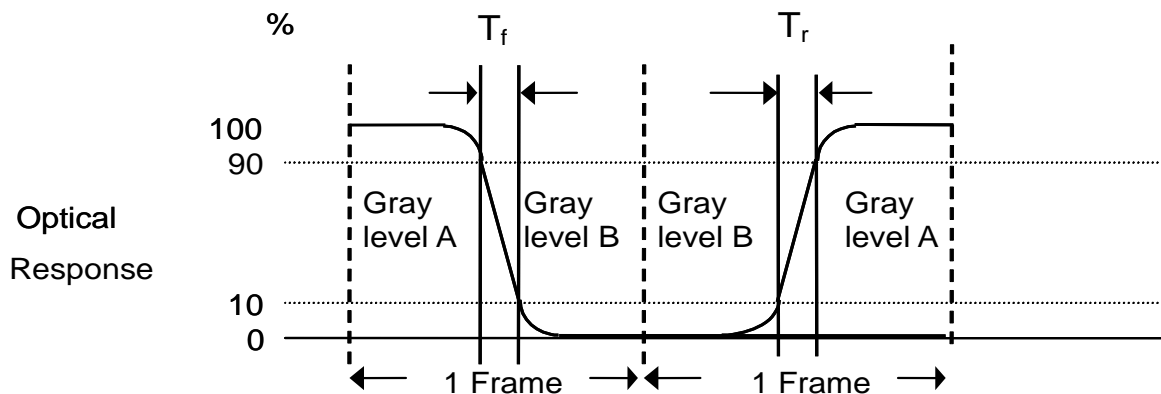

Gray Level to Gray Level		Target gray level				
		L0	L63	L127	L191	L255
Start gray level	L0					
	L63					
	L127					
	L191					
	L255					

■  $T_{GTG\_typ}$  is the total average time at rising time and falling time of gray to gray.

**Note 1-6:** Crosstalk measurement

**Definition:**

$CT = \text{Max.} (CTH, CTV);$

Where

a. Maximum Horizontal Crosstalk :

$CTH = \text{Max.} (|Y_{BL} - Y_{AL}| / Y_{AL} \times 100 \%, |Y_{BR} - Y_{AR}| / Y_{AR} \times 100 \%);$

Maximum Vertical Crosstalk:

$CTV = \text{Max.} (|Y_{BU} - Y_{AU}| / Y_{AU} \times 100 \%, |Y_{BD} - Y_{AD}| / Y_{AD} \times 100 \%);$

b.  $Y_{AU}, Y_{AD}, Y_{AL}, Y_{AR}$  = Luminance of measured location without Black pattern

$Y_{BU}, Y_{BD}, Y_{BL}, Y_{BR}$  = Luminance of measured location with Black pattern

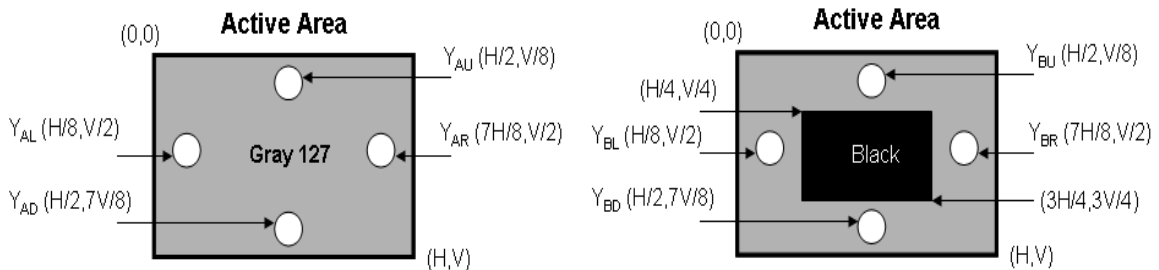

**1.3. Mechanical Characteristics**

The contents provide general mechanical characteristics for the model P215HAN02.0 In addition the figures in the next page are detailed mechanical drawing of the LCD.

Item	Dimension	Unit	Note
Outline Dimension	Horizontal	501.1	mm
	Vertical	292.2	mm
	Depth (typ)	16.12	mm
Weight	2100	G	

**1.3.1. Placement Suggestions**

1. Landscape Mode: The default placement is T-Con Side on the lower side and the image is shown upright via viewing from the front.
2. Portrait Mode: The default placement is that T-Con side has to be placed on the left side via viewing from the front.

Landscape (Front view)

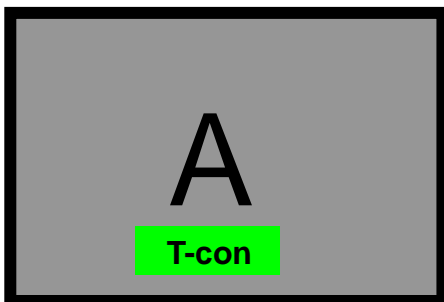

Portrait (Front view)

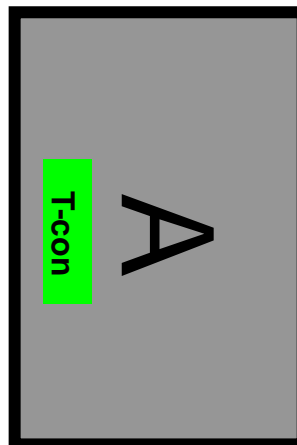

1.3.2. Mechanical Characteristics

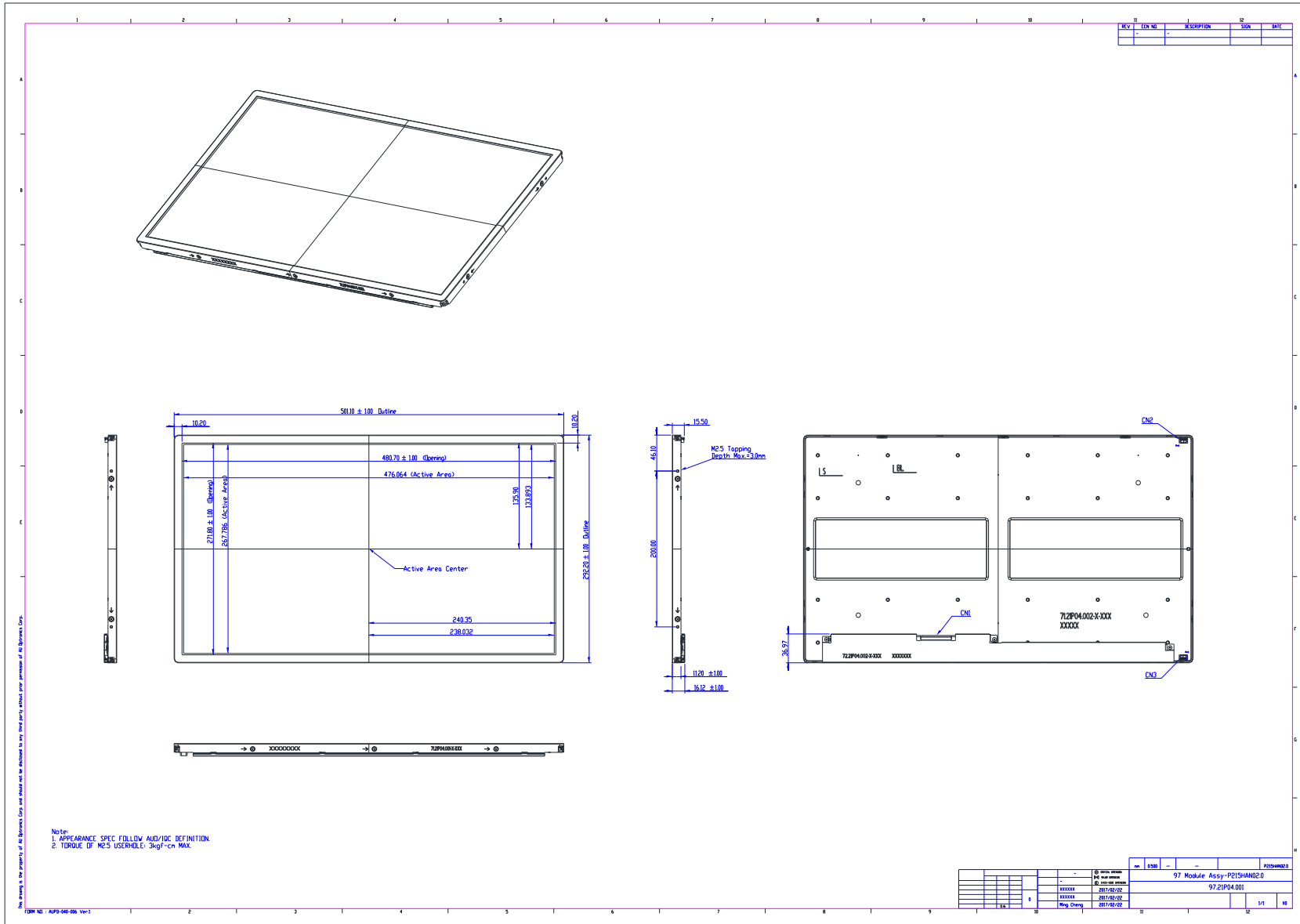

**1.3.3. Absolute Maximum Ratings**

The followings are maximum values which, if exceeded, may cause faulty operation or damage to the unit  
Permanent damage may occur if exceeding the following maximum rating.

Item	Symbol	Min	Max	Unit	Conditions
Operating Temperature	TOP	-20	+50	[°C]	Note 1-7
Operating Humidity	HOP	10	90	[%RH]	Note 1-7
Storage Temperature	TST	-20	+60	[°C]	Note 1-7
Storage Humidity	HST	10	90	[%RH]	Note 1-7
Panel Surface Temperature	PST		65	[°C]	Note 1-8

**Note 1-7:** Maximum Wet-Bulb should be 39°C and No condensation.

The relative humidity must not exceed 90% non-condensing at temperatures of 40°C or less. At temperatures greater than 40°C, the wet bulb temperature must not exceed 39°C.

**Note 1-8:** Surface temperature is measured at 50°C dry condition.

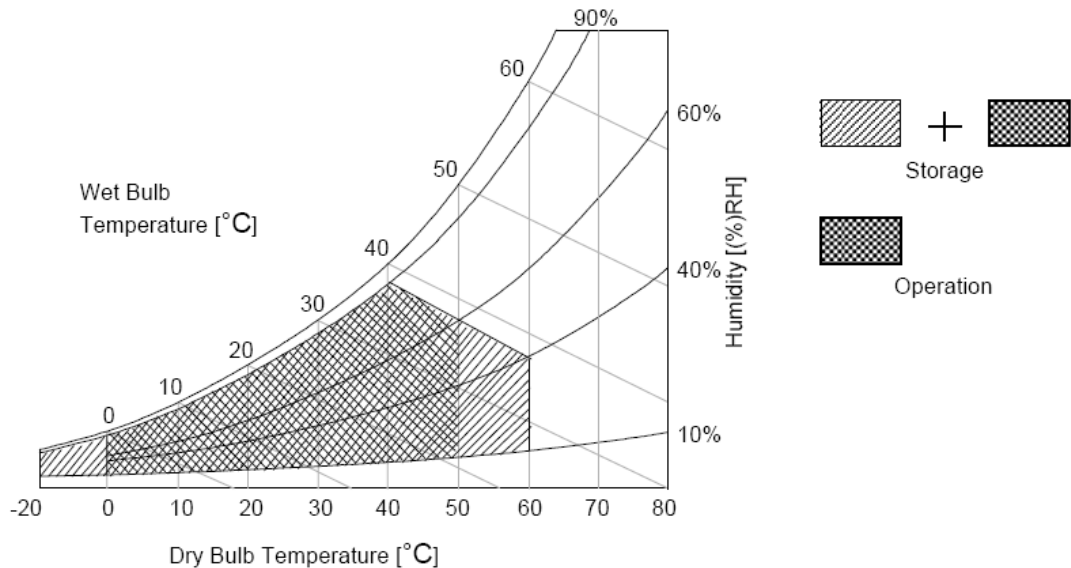

## 2. Electrical Specification

The P215HAN02.0 requires two power inputs. One is employed to power the LCD electronics and to drive the TFT array and liquid crystal. The other is to power Back Light Unit.

### 2.1. Block Diagram

The following shows the block diagram of the 21.5 inch Color TFT-LCD Module.

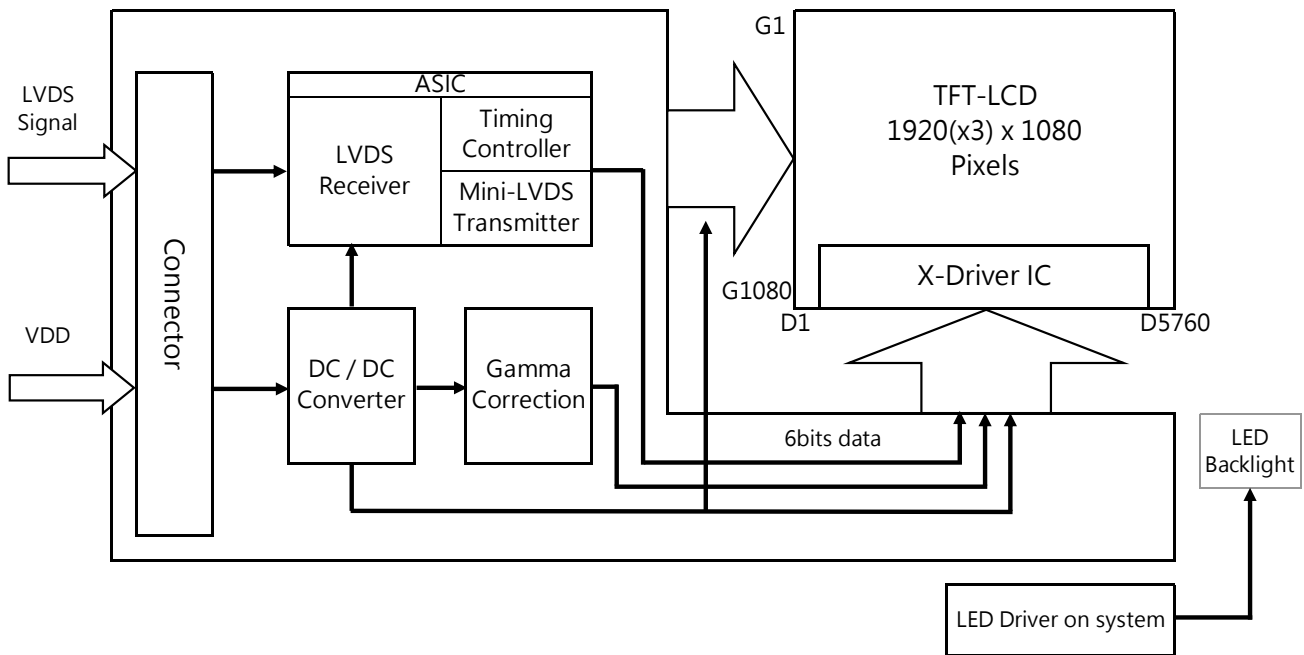

## 2.2. Interface Connection

### 2.2.1. Connector Type

TFT-LCD Connector(CN1)	Manufacturer	P-TWO	STM
	Part Number	187034-3009	MSBKT2407P30HB
Mating Connector	Manufacturer	JAE	
	Part Number	FI-X30HL (Locked Type)	

### 2.2.2. Connector Pin Assignment

PIN #	Symbol	Description	Remark
1	RxO0-	Negative LVDS differential data input (Odd data)	
2	RxO0+	Positive LVDS differential data input (Odd data)	
3	RxO1-	Negative LVDS differential data input (Odd data)	
4	RxO1+	Positive LVDS differential data input (Odd data)	
5	RxO2-	Negative LVDS differential data input (Odd data)	
6	RxO2+	Positive LVDS differential data input (Odd data)	
7	GND	Ground	
8	RxOCLK-	Negative LVDS differential clock input (Odd clock)	
9	RxOCLK+	Positive LVDS differential clock input (Odd clock)	
10	RxO3-	Negative LVDS differential data input (Odd data)	
11	RxO3+	Positive LVDS differential data input (Odd data)	
12	RxE0-	Negative LVDS differential data input (Even data)	
13	RxE0+	Positive LVDS differential data input (Even data)	
14	GND	Ground	
15	RxE1-	Negative LVDS differential data input (Even data)	
16	RxE1+	Positive LVDS differential data input (Even data)	
17	GND	Ground	
18	RxE2-	Negative LVDS differential data input (Even data)	
19	RxE2+	Positive LVDS differential data input (Even data)	
20	RxECLK-	Negative LVDS differential clock input (Even clock)	
21	RxECLK+	Positive LVDS differential clock input (Even clock)	
22	RxE3-	Negative LVDS differential data input (Even data)	
23	RxE3+	Positive LVDS differential data input (Even data)	
24	GND	Ground	
25	NC	No connection (for AUO test only. Do not connect)	
26	NC	No connection (for AUO test only. Do not connect)	
27	NC	No connection (for AUO test only. Do not connect)	
28	VDD	Power Supply Input Voltage	
29	VDD	Power Supply Input Voltage	
30	VDD	Power Supply Input Voltage	

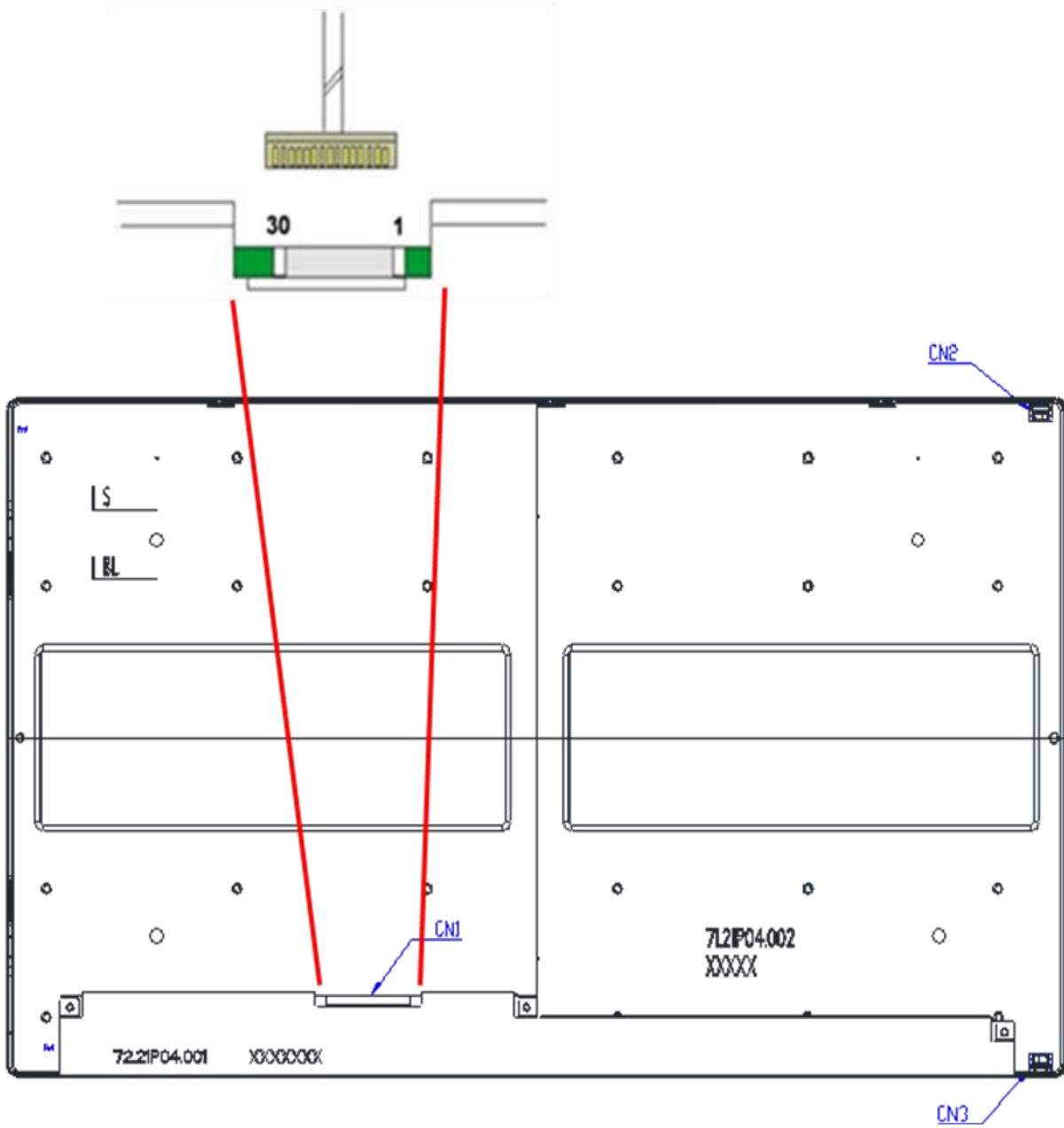



**2.3. Electrical Characteristics**

**2.3.1. Absolute Maximum Rating**

Permanent damage may occur if exceeding the following maximum rating.

Symbol	Description	Min	Max	Unit	Remark
VDD	Power Supply Input Voltage	GND-0.3	6.0	[Volt]	Ta=25°C

**2.3.2. Recommended Operating Condition**

Symbol	Description	Min	Typ	Max	Unit	Remark
VDD	Power supply Input voltage	4.5	5.0	5.5	[Volt]	
IDD	Power supply Input Current (RMS)	-	0.46	0.55	[A]	VDD= 5.0V, All white Pattern, Fv=60Hz
			0.50	0.60	[A]	VDD= 5.0V, All white Pattern, Fv=75Hz
PDD	VDD PowerVDD Power Consumption	-	2.30	2.75	[Watt]	VDD= 5.0V, All white Pattern, Fv=60Hz
			2.50	3.00	[Watt]	VDD= 5.0V, All white Pattern, Fv=75Hz
IRush	Inrush Current	-	-	3.0	[A]	Note 2-1
VDDrp	Allowable VDD Ripple Voltage	-	-	500	[mV]	VDD= 5.0V, All white Pattern, Fv=75Hz
LTLED	LED Life Time	70,000			[Hours]	Note 2-2

**Note 2-1:** Inrush Current measurement:

Test circuit:

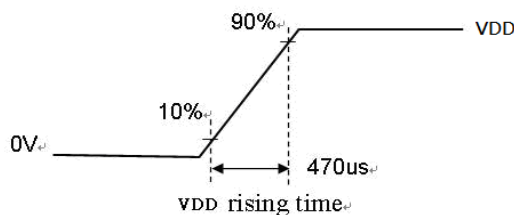
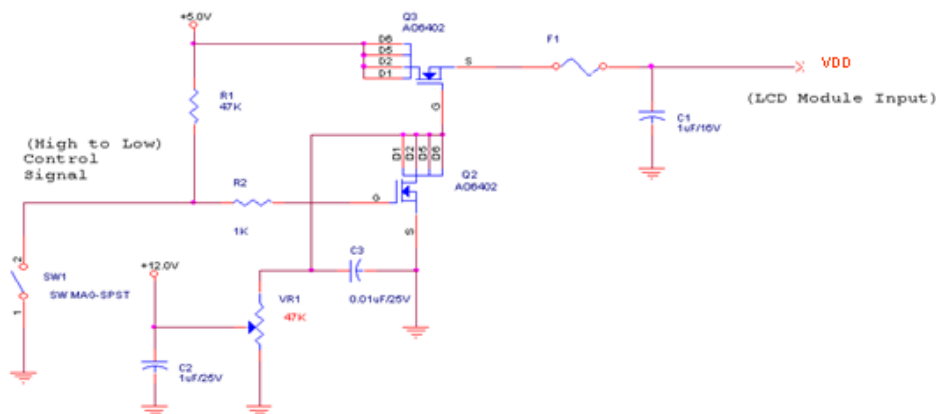

The duration of VDD rising time: 470us.

**Note 2-2:** Definition of life time:

- a. Brightness of LED becomes to 50% of its original value
- b. Test condition:  $I_s = 47\text{mA}$  and  $25^\circ\text{C}$  (Room Temperature)

**2.4. Signal Characteristics**

**2.4.1. LCD Pixel Format**

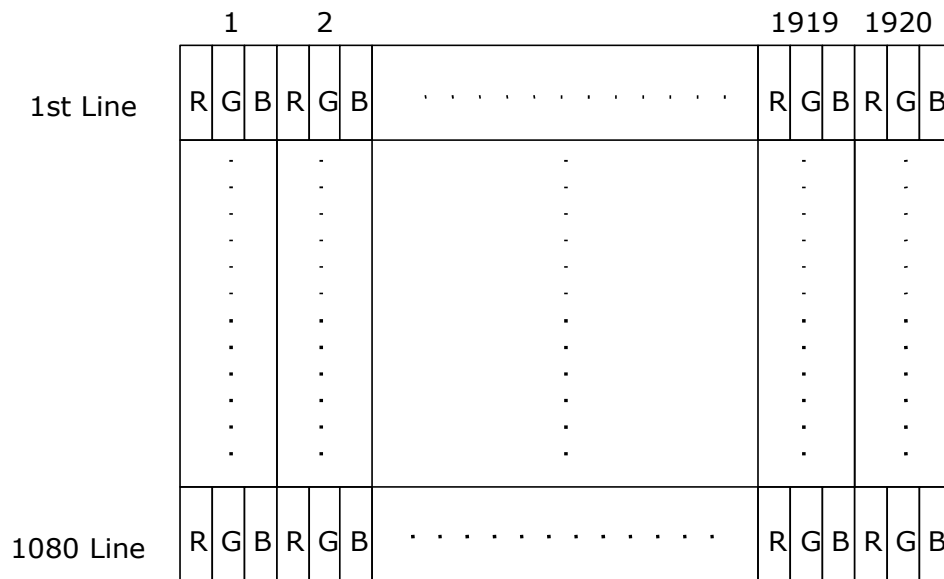

**2.4.2. LVDS Data Format**

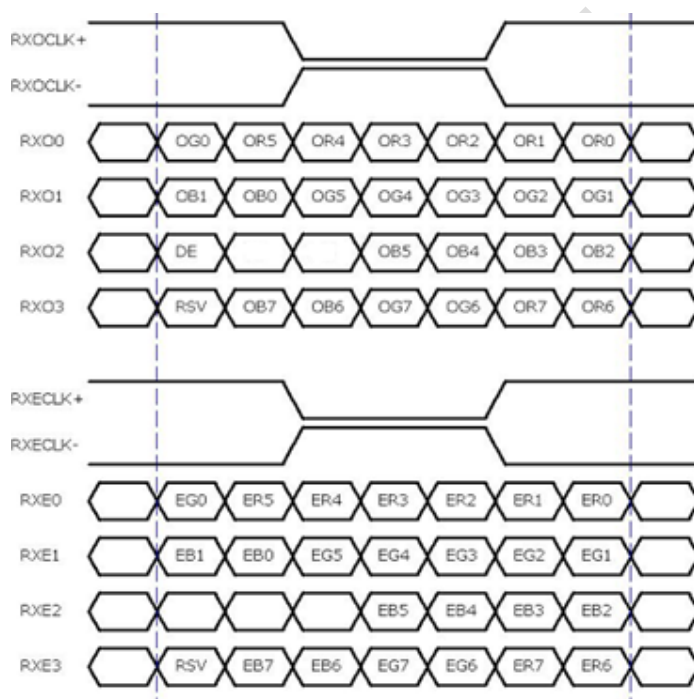

8 Bit Color Bit Order			
<b>MSB</b>	R7	G7	B7
	R6	G6	B6
	R5	G5	B5
	R4	G4	B4
	R3	G3	B3
	R2	G2	B2
	R1	G1	B1
<b>LSB</b>	R0	G0	B0

**Note 2-3:**

- a. O = "Odd Pixel Data"    E = "Even Pixel Data"
- b. Refer to 3.4.1 LCD pixel format, the 1st data is 1 (Odd Pixel Data), the 2nd data is 2 (Even Pixel Data) and the last data is 1920 (Even Pixel Data).

### 2.4.3. Color versus Input Data

The following table is for color versus input data (8bit). The higher the gray level, the brighter the color.

Color	Gray Level	Color Input Data																								Remark
		RED data (MSB:R7, LSB:R0)								GREEN data (MSB:G7, LSB:G0)								BLUE data (MSB:B7, LSB:B0)								
		R7	R6	R5	R4	R3	R2	R1	R0	G7	G6	G5	G4	G3	G2	G1	G0	B7	B6	B5	B4	B3	B2	B1	B0	
Black	-	0	0	0	0	0	0	0	0	0	0	0	0	0	0	0	0	0	0	0	0	0	0	0	0	
White	-	1	1	1	1	1	1	1	1	1	1	1	1	1	1	1	1	1	1	1	1	1	1	1	1	
Gray 127	-	0	1	1	1	1	1	1	1	0	1	1	1	1	1	1	1	0	1	1	1	1	1	1	1	
Red	L0	0	0	0	0	0	0	0	0	0	0	0	0	0	0	0	0	0	0	0	0	0	0	0	0	Black
	:	:	:	:	:	:	:	:	:	:	:	:	:	:	:	:	:	:	:	:	:	:	:	:	:	
	L255	1	1	1	1	1	1	1	1	0	0	0	0	0	0	0	0	0	0	0	0	0	0	0	0	
Green	L0	0	0	0	0	0	0	0	0	0	0	0	0	0	0	0	0	0	0	0	0	0	0	0	0	Black
	:	:	:	:	:	:	:	:	:	:	:	:	:	:	:	:	:	:	:	:	:	:	:	:	:	
	L255	0	0	0	0	0	0	0	0	1	1	1	1	1	1	1	1	0	0	0	0	0	0	0	0	
Blue	L0	0	0	0	0	0	0	0	0	0	0	0	0	0	0	0	0	0	0	0	0	0	0	0	0	Black
	:	:	:	:	:	:	:	:	:	:	:	:	:	:	:	:	:	:	:	:	:	:	:	:	:	
	L255	0	0	0	0	0	0	0	0	0	0	0	0	0	0	0	0	1	1	1	1	1	1	1	1	

### 2.4.4. LVDS Specification

#### a. DC Characteristics:

Symbol	Description	Min	Typ	Max	Units	Condition
VTH	LVDS Differential Input High Threshold	-	-	+100	[mV]	VCM = 1.2V
VTL	LVDS Differential Input Low Threshold	-100	-	-	[mV]	VCM = 1.2V
VID	LVDS Differential Input Voltage	100	-	600	[mV]	
VCM	LVDS Common Mode Voltage	+1.0	+1.2	+1.5	[V]	VTH-VTL = 200mV

**LVDS Signal Waveform:**

Use RxOCLK- & RxOCLK+ as example.

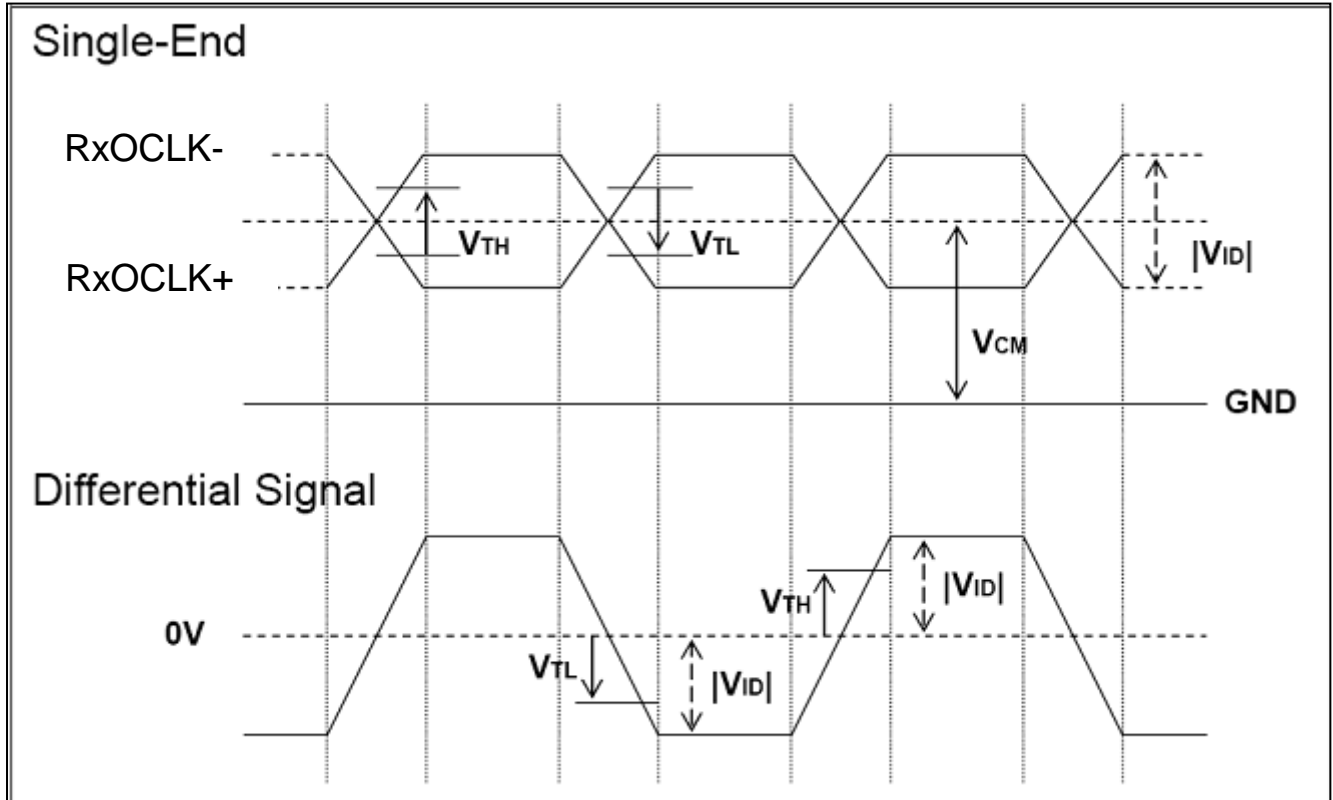

**b. AC Characteristics:**

Symbol	Description	Min	Max	Unit	Remark
FDEV	Maximum deviation of input clock frequency during Spread Spectrum	-	$\pm 3$	%	
FMOD	Maximum modulation frequency of input clock during Spread Spectrum	-	200	KHz	

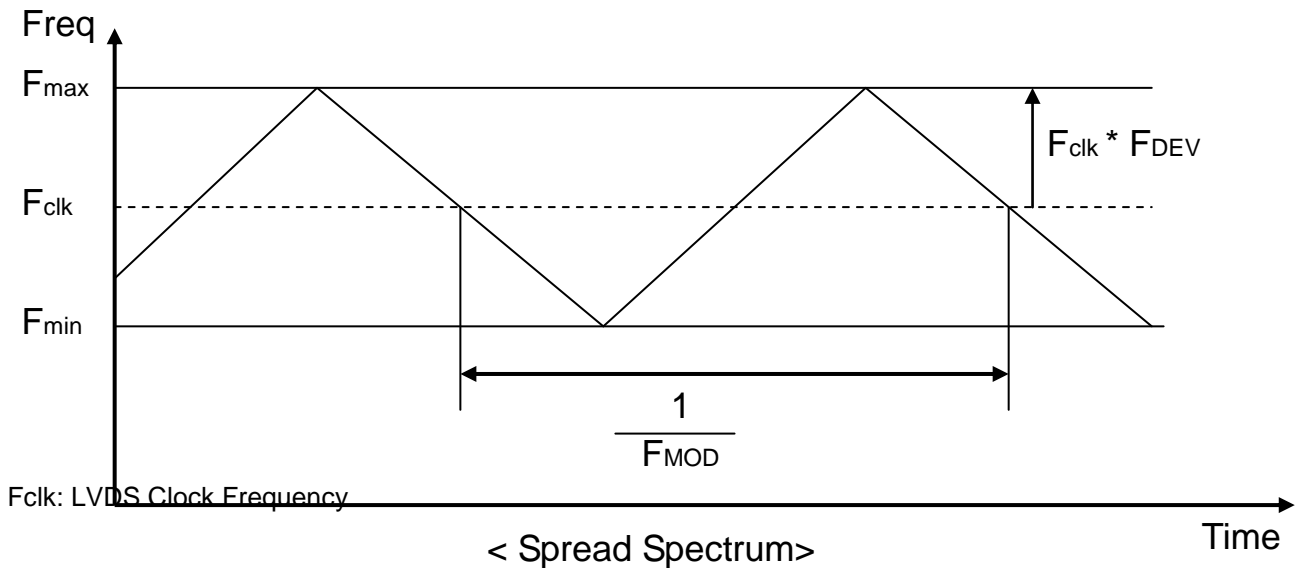

### 2.4.5. Input Timing Specification

It only support DE mode, and the input timing are shown as the following table.

Symbol	Description		Min.	Typ.	Max.	Unit	Remark
Tv	Vertical Section	Period	1094	1130	1836	Th	
Tdisp (v)		Active	1080	1080	1080	Th	
Tblk (v)		Blanking	14	50	756	Th	
Fv		Frequency	49	60	76	Hz	
Th	Horizontal Section	Period	1000	1050	1678	Tclk	
Tdisp (h)		Active	960	960	960	Tclk	
Tblk (h)		Blanking	40	90	718	Tclk	
Fh		Frequency	53.7	67.8	90.0	KHz	<b>Note 2-4</b>
Tclk	LVDS Clock	Period	11.2	14.0	18.6	ns	1/Fclk
Fclk		Frequency	53.7	71.2	90.0	MHz	<b>Note 2-5</b>

**Note 2-4:** The equation is listed as following. Please don't exceed the above recommended value.

$$Fh (\text{Min.}) = Fclk (\text{Min.}) / Th (\text{Min.});$$

$$Fh (\text{Typ.}) = Fclk (\text{Typ.}) / Th (\text{Typ.});$$

$$Fh (\text{Max.}) = Fclk (\text{Max.}) / Th (\text{Min.});$$

**Note 2-5:** The equation is listed as following. Please don't exceed the above recommended value.

$$Fclk (\text{Min.}) = Fv (\text{Min.}) \times Th (\text{Min.}) \times Tv (\text{Min.});$$

$$Fclk (\text{Typ.}) = Fv (\text{Typ.}) \times Th (\text{Typ.}) \times Tv (\text{Typ.});$$

$$Fclk (\text{Max.}) = Fv (\text{Max.}) \times Th (\text{Typ.}) \times Tv (\text{Typ.});$$

**2.4.6. Input Timing Diagram**

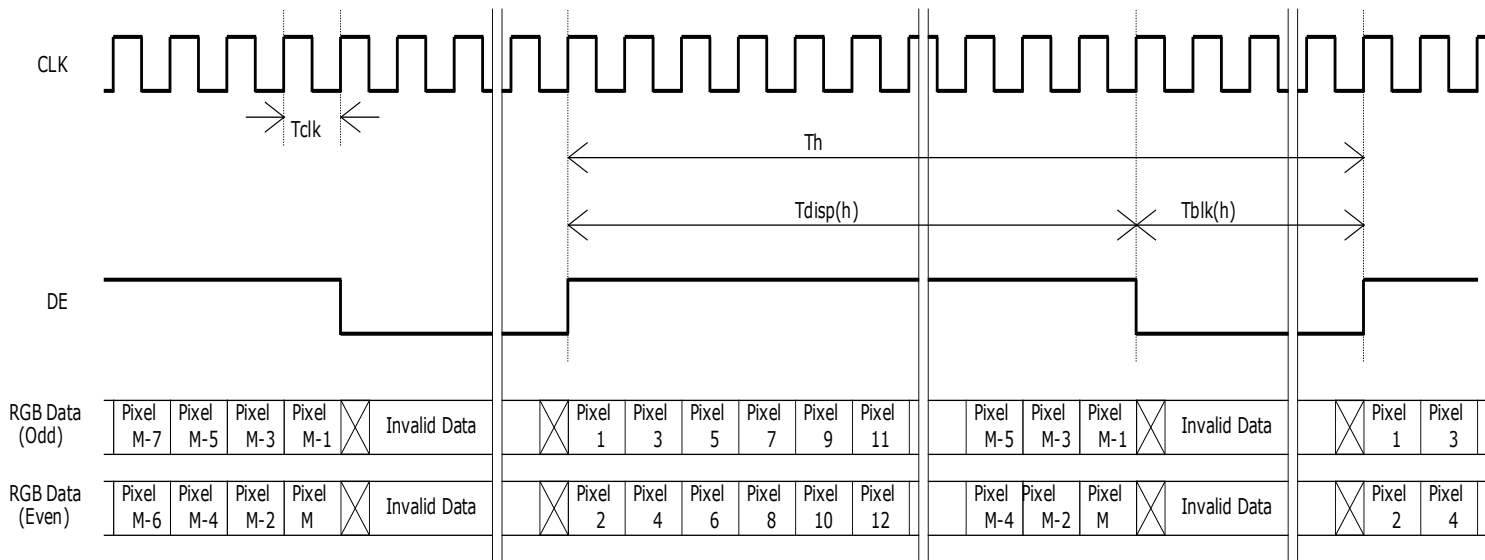
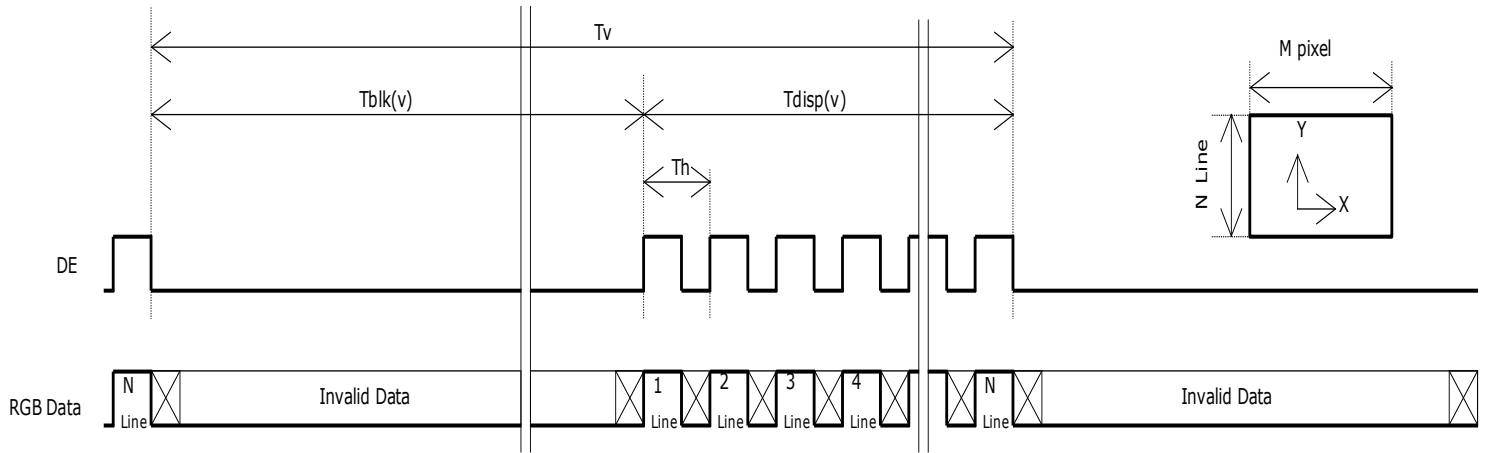



**2.5. Power ON/OFF Sequence**

VDD power, LVDS signal and backlight on/off sequence are as following. LVDS signals from any system shall be Hi-Z state when VDD is off.

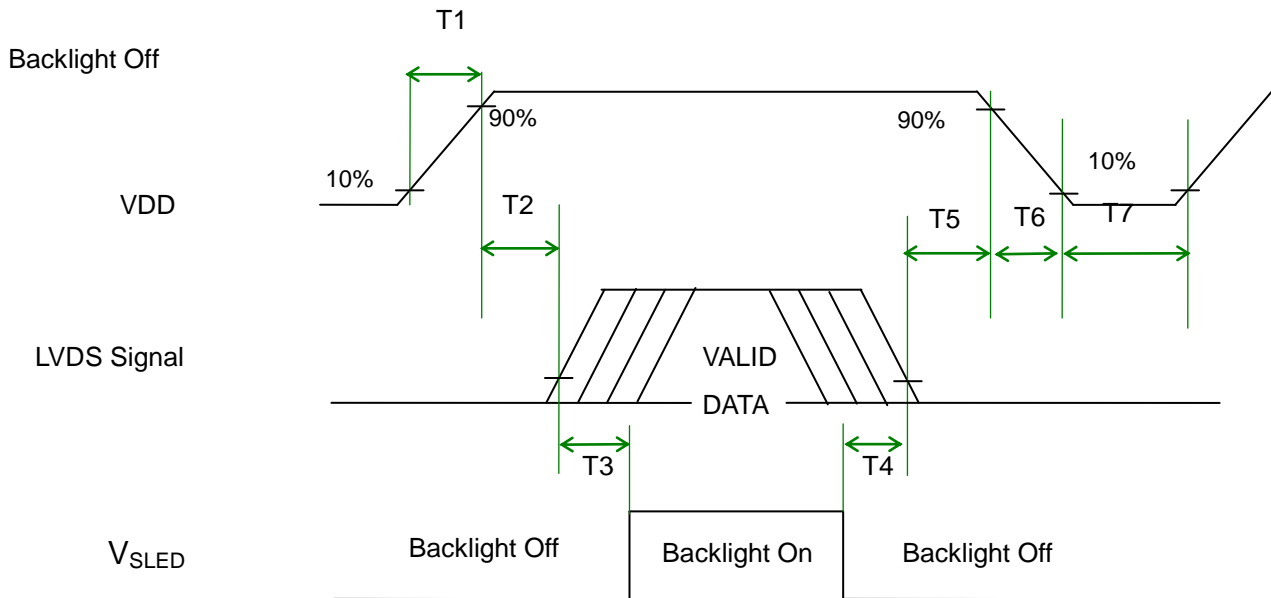

**Power Sequence Timing**

Symbol	Value			Unit	Remark
	Min.	Typ.	Max.		
T1	0.5	-	10	[ms]	
T2	0	-	50	[ms]	
T3	500	-	-	[ms]	
T4	100	-	-	[ms]	
T5	0	-	50	[ms]	Note 2-6 Note 2-7
T6	0	-	200	[ms]	Note 2-7 Note 2-8
T7	1000	-	-	[ms]	

**Note 2-6 :** Recommend setting T5 = 0ms to avoid electronic noise when VDD is off.

**Note 2-7 :** During T5 and T6 period , please keep the level of input LVDS signals with Hi-Z state.

**Note 2-8 :** Voltage of VDD must decay smoothly after power-off. (customer system decide this value)

### 3. Backlight Unit

#### 3.1. Block Diagram

The following shows the block diagram of the 21.5 inch Backlight Unit. And it's included 2pcs of LED light bar in Backlight Unit. Each of LED light bar is included 68 pcs of LED package.(4 strings with 17 pcs LED of each string).

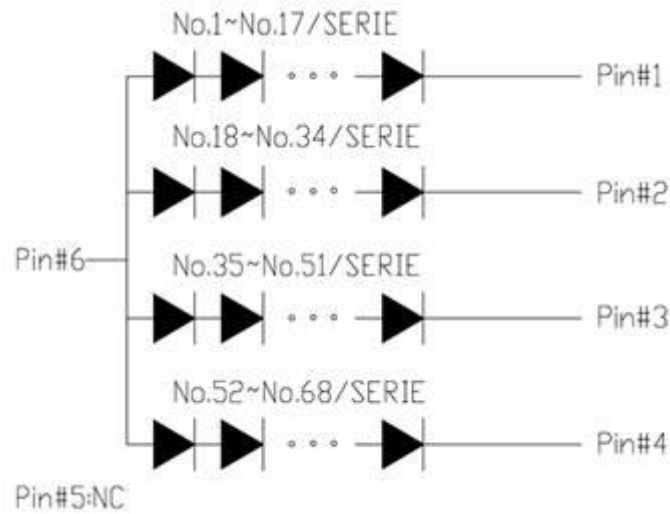

**3.2. Interface Connection**

**3.2.1. Connector Type**

Backlight Connector (CN2/CN3)	Manufacturer	CviLux
	Part Number	CI16M1VRA-NH

**Mating Connector dimension:**

Material:

Base: High temperature plastic UL 94V-0, Color Nature

Contact: Copper alloy

Tab: Copper alloy with Matte Tin plated

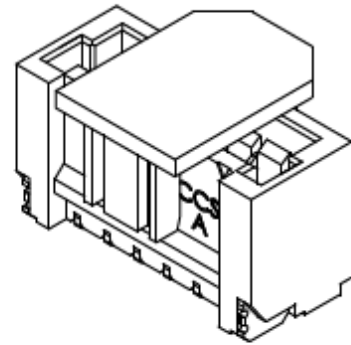
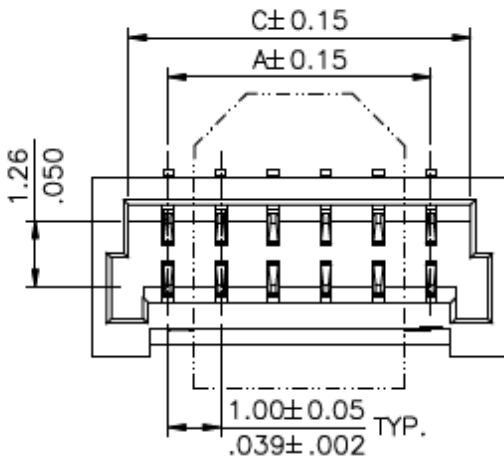

DIM. A = 1.00 x NO. OF SPACES  
 DIM. B = DIM. A + 2.90  
 DIM. C = DIM. A + 1.50  
 \* AVAILABLE IN 2 THROUGH 20

**3.2.2. Connector Pin Assignment**

**CN2**

LED Lightbar Connector Manufacture			CVILUX:CI1606M1VRA-NH
PIN	SYMBOL	FUNCTION	
1	Vc(1)	LED Cathode (Negative)	
2	Vc(2)	LED Cathode (Negative)	
3	Vc(3)	LED Cathode (Negative)	
4	Vc(4)	LED Cathode (Negative)	
5	NC	NC	
6	Va(1)	LED Anode (Positive)	

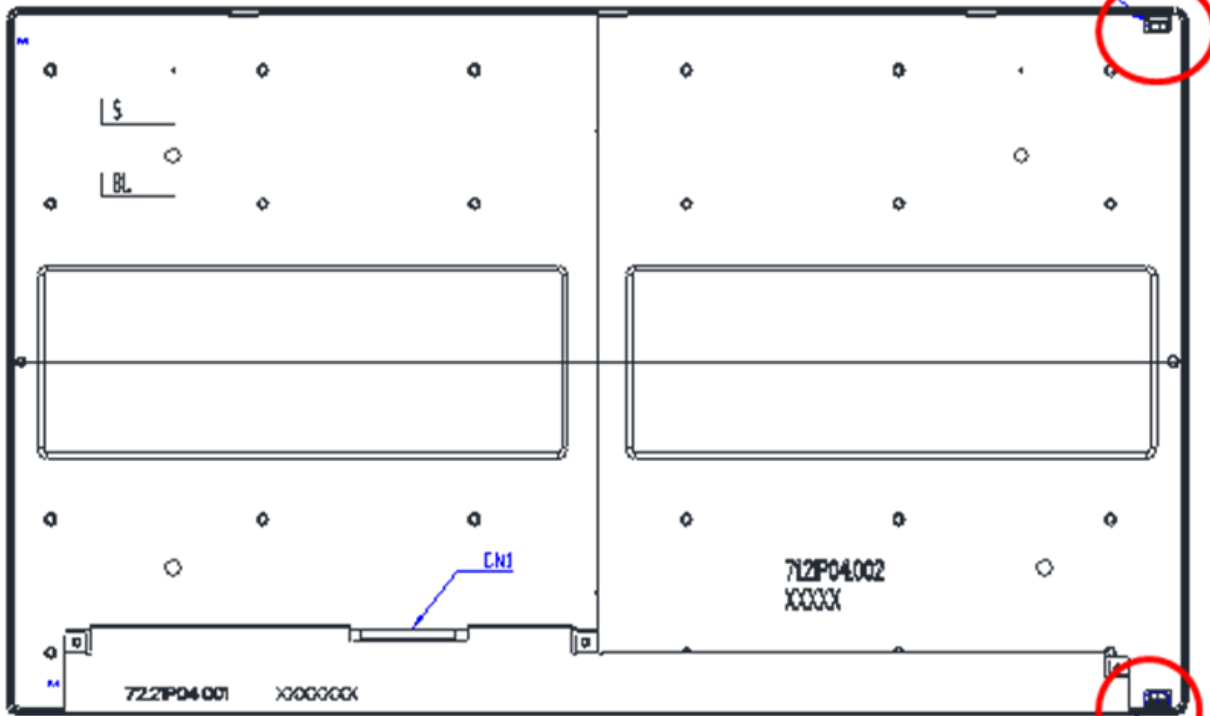

**CN3**

LED Lightbar Connector Manufacture			CVILUX:CI1606M1VRA-NH
PIN	SYMBOL	FUNCTION	
1	Vc(1)	LED Cathode (Negative)	
2	Vc(2)	LED Cathode (Negative)	
3	Vc(3)	LED Cathode (Negative)	
4	Vc(4)	LED Cathode (Negative)	
5	NC	NC	
6	Va(1)	LED Anode (Positive)	

### 3.3. Electrical Characteristics

#### 3.3.1. Absolute Maximum Rating

Permanent damage may occur if exceeding the following maximum rating.

(Ta=25°C)

Symbol	Description	Min	Max	Unit	Remark
Is	LED String Current	0	51	[mA]	100% duty ratio
			120	[mA]	Duty ratio ≤ 10% Pulse time=10 ms

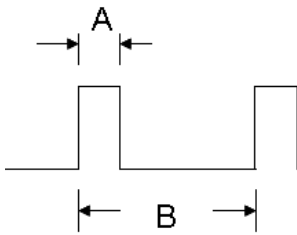

Duty ratio= (A / B) X 100% ; (A: Pulse time, B: Period)

#### 3.3.2. Recommended Operating Condition

(Ta=25°C)

Symbol	Description	Min.	Typ.	Max.	Unit	Remark
Is	LED String Current	-	47	51	[mA]	100% duty ratio of LED chip, <b>Note 3-4</b>
Vs	LED String Voltage	91.8	95.2	109.3	[Volt]	Is=47mA @ 100% duty ratio; <b>Note 3-1</b>
P <sub>BLU</sub>	LED Light Bar Power Consumption	-	35.8	-	[Watt]	<b>Note 3-2</b>
LT <sub>LED</sub>	LED Life Time	70,000	-	-	[Hour]	<b>Note 3-3</b>

**Note 3-1:**  $V_s (\text{Typ.}) = V_F (\text{Typ.}) \times \text{LED No. (one string)}$ ;

a.  $V_F$ : LED chip forward voltage,  $V_F (\text{Min.}) = 5.4\text{V}$ ,  $V_F (\text{Typ.}) = 5.6\text{V}$ ,  $V_F (\text{Max.}) = 6.43\text{V}$

b. The same equation to calculate  $V_s (\text{Min.})$  &  $V_s (\text{Max.})$  for respective  $V_F (\text{Min.})$  &  $V_F (\text{Max.})$ ;

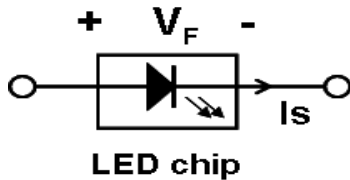

**Note 3-2:**  $P_{\text{BLU}} (\text{Typ.}) = V_s (\text{Typ.}) \times I_s (\text{Typ.}) \times 8$  ; ( 8 is total String No. of LED Light bar)

$P_{\text{BLU}} (\text{Max.}) = V_s (\text{Max.}) \times I_s (\text{Typ.}) \times 8$  ;

**Note 3-3:** Definition of life time:

a. Brightness of LED becomes to 50% of its original value

b. Test condition:  $I_s = 47\text{mA}$  and  $25^\circ\text{C}$  (Room Temperature)

**Note 3-4:** AUO strongly recommend "Analog Dimming" method for backlight brightness control for Wavy Noise Free. Otherwise, recommend that Dimming Control Signal (PWM Signal) should be synchronized with Frame Frequency.

## 4. Reliability Test Items

AUO reliability test items are listed as following table. (*Bare Panel only*)

	Test Item	Q'ty	Condition
1	High temperature storage test	3	60°C, 500hrs
2	Low temperature storage test	3	-20°C, 500hrs
3	High temperature operation test	3	50°C, 500hrs
4	Low temperature operation test	3	-20°C, 500hrs
5	Vibration test (With carton)	1CTN/7PCS	Acceleration: 1.04 Grms Wave: Random. Frequency: 2 - 200 Hz Sweep: 20 Minutes each Axis (X, Y, Z)
6	Drop test (With carton)	1CTN/7PCS	Height: 61cm Direction: 1 Corner-3 Edge-6 Faces (ASTMD4169-I)
7	Vibration test (non-operation)	3	Wave form: random Vibration level : 1.0G RMS Bandwidth : 3-300Hz Duration : X axis, Vertical, 30min Y axis, Vertical, 30min Z axis, Vertical, 30min one time each direction
8	Shock test (non-operation)	3	Shock level 50G ,20ms ±X,Y,Z axis Waveform: half sine wave Direction: One time each direction

## **5. International Standard**

### **5.1. Safety**

- (1) UL 60950-1; Standard for Safety of Information Technology Equipment Including electrical Business Equipment.
- (2) IEC 60950-1; Standard for Safety of International Electrotechnical Commission
- (3) EN 60950-1; European Committee for Electrotechnical Standardization (CENELEC), EUROPEAN STANDARD for Safety of Information Technology Equipment Including Electrical Business Equipment.

### **5.2. EMC**

- (1) ANSI C63.4 “Methods of Measurement of Radio-Noise Emissions from Low-Voltage Electrical and Electrical Equipment in the Range of 9kHz to 40GHz. “American National standards Institute(ANSI), 1992
- (2) C.I.S.P.R “Limits and Methods of Measurement of Radio Interface Characteristics of Information Technology Equipment.” International Special committee on Radio Interference.
- (3) EN 55022 “Limits and Methods of Measurement of Radio Interface Characteristics of Information Technology Equipment.” European Committee for Electrotechnical Standardization. (CENELEC), 1998



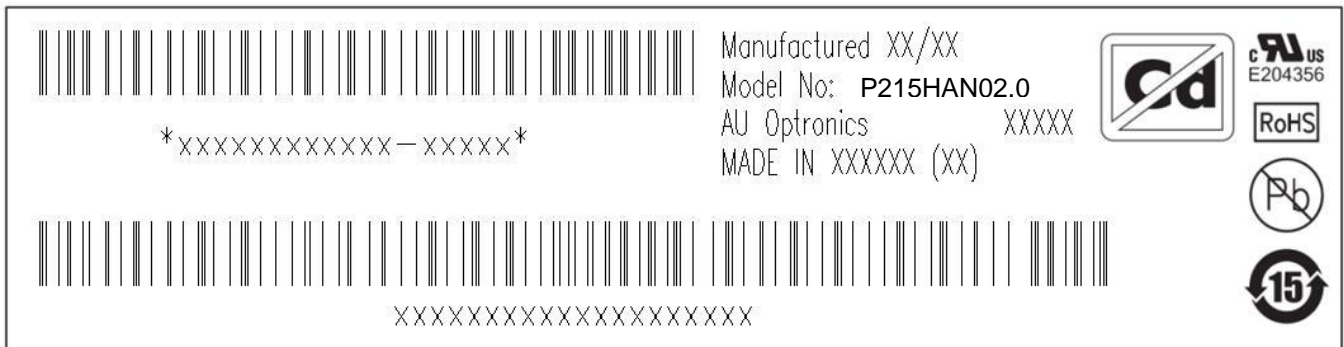
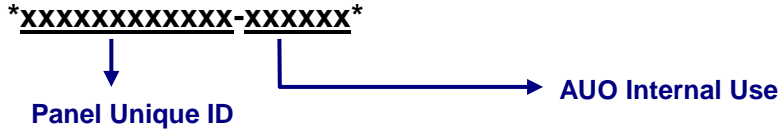

## 6. Packing

### 6.1. Definition of Label



### Green mark description

- (1) For Pb Free Product, AUO will add  for identification.
- (2) For RoHs compatible products, AUO will add  for identification.
- (3) For "Cadmium Free product, AUO will add  for identification.
- (4) Note: The green Mark will be present only when the green documents have been ready by AUO internal green team. (definition of green design follows the AUO green design checklist.)

### B. Carton Label:

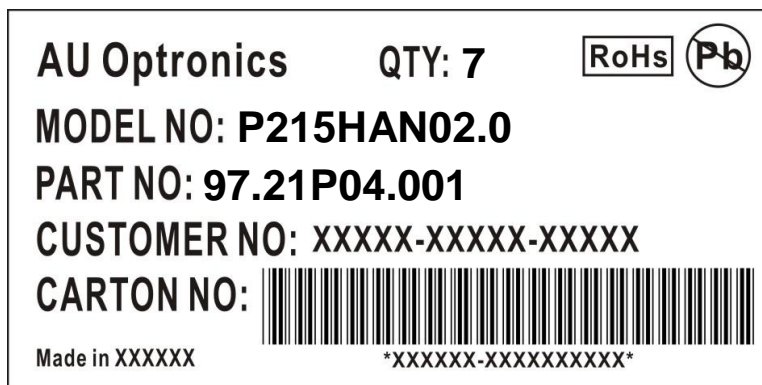

**6.2. Packing Methods**

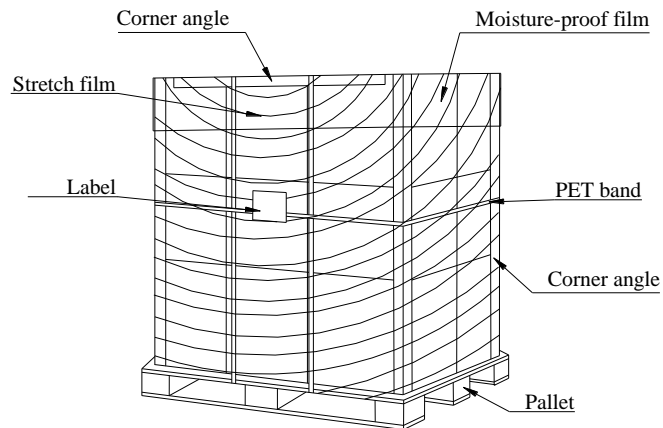
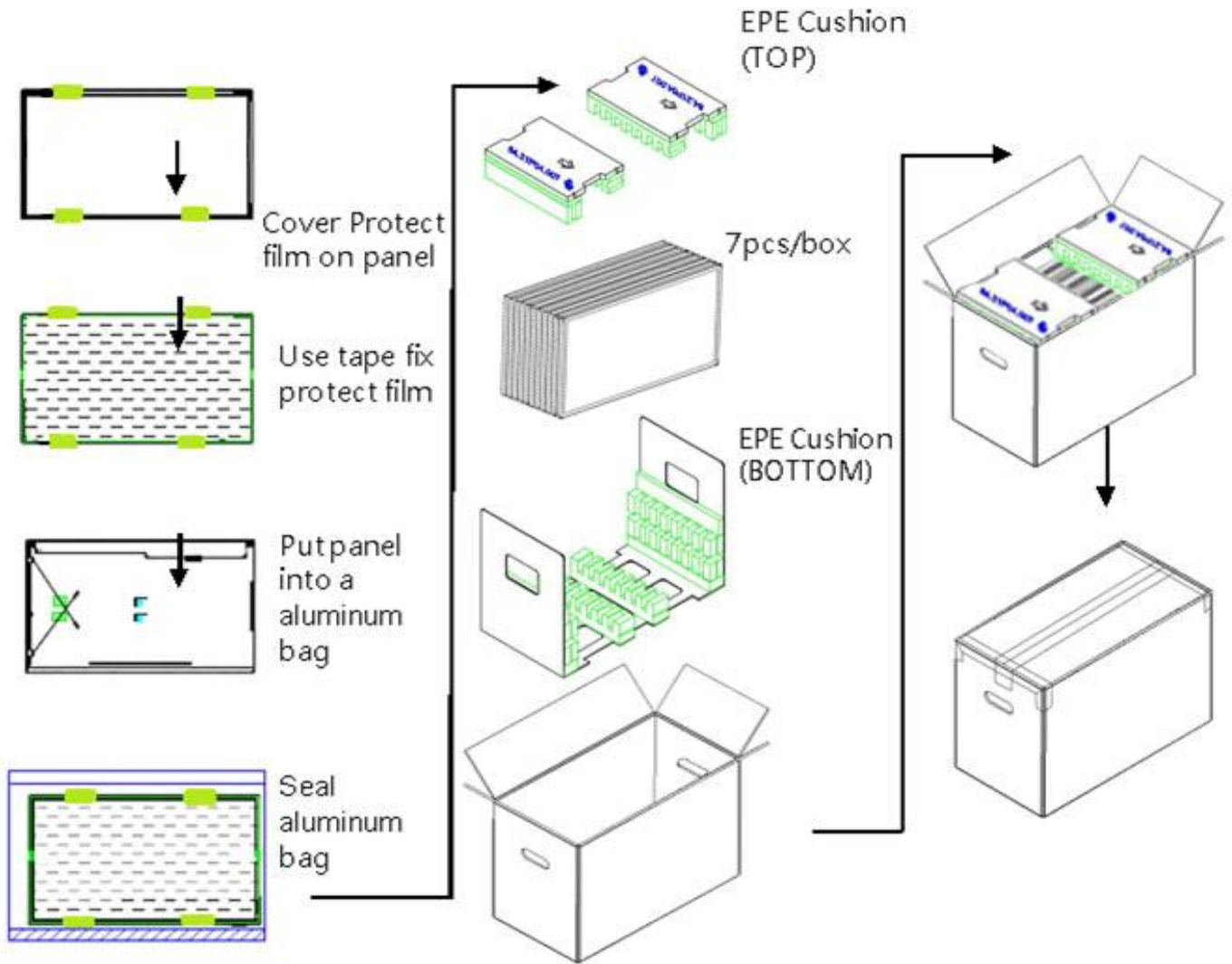

Pallet and Shipment Information

	Item	Specification			Remark
		Q'ty	Dimension	Weight(kg)	
1	Panel	1	501.1mm(H) x 292.2mm(V) x16.3(D)mm	2.1	<b>Note 1</b>
2	Cushion	1	-	0.55	
3	Box	1	564(L)mm x 300(W)mm x 393(H)mm	1.40	without Panel & cushion <b>Note 1</b>
4	Packing Box	7 pcs/Box	564 (L)mm x 300 (W)mm x 393 (H)mm	16.57	with panel & cushion <b>Note 1</b>
5	Pallet	1	1150(L)mm x 910(W)mm x 132(H)mm	13.8	<b>Note 1</b>
6	Pallet after Packing	18 boxes/pallet	1150(L)mm x 910(W)mm x 1311(H)mm	321.1	<b>Note 1</b>

**Note 1:** Estimated value which is subject to change based on real measured data.

## 7. Precautions

Please pay attention to the followings when you use this TFT LCD module.

### 7.1. Mounting Precautions

- (1) You must mount a module using holes arranged in four corners or four sides.
- (2) You should consider the mounting structure so that uneven force (ex. twisted stress) is not applied to module. And the case on which a module is mounted should have sufficient strength so that external force is not transmitted directly to the module.
- (3) Please attach the surface transparent protective plate to the surface in order to protect the polarizer. Transparent protective plate should have sufficient strength in order to resist external force.
- (4) You should adopt radiation structure to satisfy the temperature specification.
- (5) Acetic acid type and chlorine type materials for the cover case are not desirable because the former generates corrosive gas of attacking the polarizer at high temperature and the latter cause circuit broken by electro-chemical reaction.
- (6) Do not touch, push or rub the exposed polarizer with glass, tweezers or anything harder than HB pencil lead. And please do not rub with dust clothes with chemical treatment. Do not touch the surface of polarizer for bare hand or greasy cloth. (Some cosmetics are detrimental to the polarizer.)
- (7) When the surface becomes dusty, please wipe gently with absorbent cotton or other soft materials like chamois soaks with petroleum benzene. Normal-hexane is recommended for cleaning the adhesives used to attach front/ rear polarizer. Do not use acetone, toluene and alcohol because they cause chemical damage to the polarizer.
- (8) Wipe off saliva or water drops as soon as possible. Their long time contact with polarizer causes deformations and color fading.
- (9) Do not open the case because inside circuits do not have sufficient strength.

### 7.2. Operating Precautions

- (1) The spike noise causes the mis-operation of circuits. It should be lower than following voltage:  $V=\pm 200\text{mV}$ (Over and under shoot voltage)
- (2) Response time depends on the temperature. (In lower temperature, it becomes longer.)
- (3) Brightness depends on the temperature. (In lower temperature, it may become lower.) And in lower temperature, response time (required time that brightness is stable after turned on) becomes longer.
- (4) Be careful for condensation at sudden temperature change. Condensation makes damage to polarizer or electrical contacted parts. And after fading condensation, smear or spot will occur.
- (5) When fixed patterns are displayed for a long time, remnant image is likely to occur.
- (6) Module has high frequency circuits. Sufficient suppression to the electromagnetic

interference shall be done by system manufacturers. Grounding and shielding methods may be important to minimize the interface.

- (7) The conductive material and signal cables are kept away from LED driver inductor to prevent abnormal display, sound noise and temperature rising.

### **7.3. Operating Condition for Public Information Display**

The device listed in the product specification is designed and manufactured for PID (Public Information Display) application. To optimize module's lifetime and function, below operating usages are required.

#### **(1) Normal operating condition**

- A. Operating temperature: -20~50°C
- B. Operating humidity: 10~90%
- C. Display pattern: dynamic pattern (Real display).

Note) Long-term static display would cause image sticking.

#### **(2) Operation usage to protect against image sticking due to long-term static display.**

- A. Suitable operating time: under 24 hours a day.
- B. Liquid Crystal refresh time is required. Cycling display between 5 minutes' information (static) display and 10 seconds' moving image.
- C. Periodically change background and character (image) color.
- D. Avoid combination of background and character with large different luminance.

#### **(3) Periodically adopt one of the following actions after long time display.**

- A. Running the screen saver (motion picture or black pattern)
- B. Power off the system for a while

#### **(4) LCD system is required to place in well-ventilated environment. Adapting active cooling system is highly recommended.**

#### **(5) Product reliability and functions are only guaranteed when the product is used under right operation usages. If product will be used in extreme conditions, such as high temperature/humidity, display stationary patterns, or long operation time etc..., it is strongly recommended to contact AUO for filed application engineering advice. Otherwise, its reliability and function may not be guaranteed. Extreme conditions are commonly found at airports, transit stations, banks, stock market and controlling systems.**

### **7.4. Electrostatic Discharge Control**

Since a module is composed of electronic circuits, it is not strong to electrostatic discharge. Make certain that treatment persons are connected to ground through wristband etc. And don't touch interface pin directly.

### **7.5. Precautions for Strong Light Exposure**

1. Strong light exposure causes degradation of polarizer and color filter.
2. To keep display function well as a digital signage application, especially the component of TFT is very sensitive to sunlight, it is necessary to set up blocking device protecting panel from radiation of ambient environment.

### **7.6. Storage**

When storing modules as spares for a long time, the following precautions are necessary.

- (1) Store them in a dark place. Do not expose the module to sunlight or fluorescent light. Keep the temperature between 5°C and 35°C at normal humidity.
- (2) The polarizer surface should not come in contact with any other object. It is recommended that they be stored in the container in which they were shipped.
- (3) Storage condition is guaranteed under packing conditions.
- (4) The phase transition of Liquid Crystal in the condition of the low or high storage temperature will be recovered when the LCD module returns to the normal condition.

### **7.7. Handling Precautions for Protection Film**

- (1) The protection film is attached to the bezel with a small masking tape. When the protection film is peeled off, static electricity is generated between the film and polarizer. This should be peeled off slowly and carefully by people who are electrically grounded and with well ion-blown equipment or in such a condition, etc.
- (2) When the module with protection film attached is stored for a long time, sometimes there remains a very small amount of glue still on the bezel after the protection film is peeled off.
- (3) You can remove the glue easily. When the glue remains on the bezel or its vestige is recognized, please wipe them off with absorbent cotton waste or other soft material like chamois soaked with normal-hexane.