



# Product Specification

G270HAN01.0

AU OPTRONICS CORPORATION

( ) Preliminary Specifications

(✓) Final Specifications

<b>Module</b>	27 Inch Color TFT-LCD
<b>Model Name</b>	G270HAN01.0

<b>Customer</b>	<b>Date</b>
_____	_____
<b>Checked &amp; Approved by</b>	<b>Date</b>
_____	_____
Customer's sign back page	

<b>Approved by</b>	<b>Date</b>
<i>Jason CL Pan</i>	<i>Nov. 01, 2018</i>
<b>Prepared by</b>	<b>Date</b>
<i>Audrey HC Lin</i>	<i>Nov. 01, 2018</i>
General Display Business Division / AU Optronics corporation	



# Contents

- 1. Operating Precautions .....4**
- 2. General Description .....5**
  - 2.1 Display Characteristics..... 5
  - 2.2 Optical Characteristics ..... 6
- 3. Functional Block Diagram.....9**
- 4. Absolute Maximum Ratings .....10**
  - 4.1 Absolute Ratings of TFT LCD Module..... 10
  - 4.2 Absolute Ratings of Environment..... 10
- 5. Electrical Characteristics .....11**
  - 5.1 TFT LCD Module ..... 11
  - 5.2 Backlight Unit ..... 13
- 6. Signal Characteristic .....15**
  - 6.1 Pixel Format Image..... 15
  - 6.2 Scanning Direction..... 15
  - 6.3 Signal Description ..... 16
  - 6.4 The Input Data Format..... 18
  - 6.5 Interface Timing ..... 19
  - 6.6 Power ON/OFF Sequence ..... 21
- 7. Reliability Test Criteria .....22**
- 8. Mechanical Characteristics.....23**
  - 8.1 LCM Outline Dimension ..... 23
- 9. Label and Packaging .....25**
  - 9.1 Shipping Label (on the rear side of TFT-LCD display) ..... 25
  - 9.2 Carton Package ..... 25
- 10 Safety .....26**
  - 10.1 Sharp Edge Requirements..... 26
  - 10.2 Materials ..... 26
  - 10.3 Capacitors..... 26
  - 10.4 National Test Lab Requirement..... 26



## 1. Operating Precautions

- 1) Since front polarizer is easily damaged, please be cautious and not to scratch it.
- 2) Be sure to turn off power supply when inserting or disconnecting from input connector.
- 3) Wipe off water drop immediately. Long contact with water may cause discoloration or spots.
- 4) When the panel surface is soiled, wipe it with absorbent cotton or soft cloth.
- 5) Since the panel is made of glass, it may be broken or cracked if dropped or bumped on hard surface.
- 6) To avoid ESD (Electro Static Discharge) damage, be sure to ground yourself before handling TFT-LCD Module.
- 7) Do not open nor modify the module assembly.
- 8) Do not press the reflector sheet at the back of the module to any direction.
- 9) In case if a module has to be put back into the packing container slot after it was taken out from the container, do not press the center of the LED light bar edge. Instead, press at the far ends of the LED light bar edge softly. Otherwise the TFT Module may be damaged.
- 10) At the insertion or removal of the Signal Interface Connector, be sure not to rotate nor tilt the Interface Connector of the TFT Module.
- 11) TFT-LCD Module is not allowed to be twisted & bent even force is added on module in a very short time. Please design your display product well to avoid external force applying to module by end-user directly.
- 12) Small amount of materials having no flammability grade is used in the LCD module. The LCD module should be supplied by power complied with requirements of Limited Power Source (IEC60950 or UL1950), or be applied exemption.
- 13) Severe temperature condition may result in different luminance, response time and lamp ignition voltage.
- 14) Continuous operating TFT-LCD display under low temperature environment may accelerate lamp exhaustion and reduce luminance dramatically.
- 15) The data on this specification sheet is applicable when LCD module is placed in landscape position.
- 16) Continuous displaying fixed pattern may induce image sticking. It's recommended to use screen saver or shuffle content periodically if fixed pattern is displayed on the screen.



## 2. General Description

G270HAN01.0 is a Color Active Matrix Liquid Crystal Display composed of a TFT-LCD panel, a driver circuit, and a backlight system. The screen format is intended to support the FHD (1920(H) x 1080(V)) screen and 1.07B colors. All input signals are 2-channel LVDS interface compatible.

### 2.1 Display Characteristics

The following items are characteristics summary on the table under 25 °C condition:

Items	Unit	Specifications
Screen Diagonal	[inch]	27"
Active Area	[mm]	597.888 (H) x 336.312 (V)
Resolution		1920 x1080
Pixel Pitch	[mm]	0.3114(triad)x0.3114
Pixel Arrangement		R.G.B. Vertical Stripe
Display Mode		AHVA
Nominal Input Voltage VDD	[Volt]	12V
Power Consumption	[Watt]	Total = 43.69 W (Typ) (LCD =2.4 W, BLU =41.29 W)
Weight	[Grams]	3400 (Typ)
Physical Size	[mm]	630.0 (H) x 368.2 (V) x 22.9 (D) (Typ)
Electrical Interface		Dual Channel LVDS
Surface Treatment		Anti-Glare treatment
Support Color		1.07B Colors ,True 10Bit (RGB)
Temperature Range Operating Storage (Non-Operating)	[°C] [°C]	0 to +50 -20 to +60
RoHS Compliance		RoHS Compliance

## 2.2 Optical Characteristics

The optical characteristics are measured under stable conditions at 25 °C (Room Temperature):

Item	Unit	Conditions	Min.	Typ.	Max.	Note	
White Luminance	cd/m <sup>2</sup>	ILED=65mA(center point)	800	1000	-	1	
Uniformity	%	9 points			20	2,3	
Contrast Ratio	--		700	1000	-	4	
Response Time	msec	Rising	-	-	-	5	
		Falling	-	-	-		
		Rising + Falling	-	14	25		
Viewing Angle	degree	Horizontal CR >= 10	(Right)	75	89	-	6
			(Left)	75	89	-	
		Vertical CR >= 10	(Upper)	70	89	-	
			(Lower)	70	89	-	
Color / Chromaticity Coordinates (CIE 1931)	--	Red x	0.634	0.664	0.694		
		Red y	0.282	0.312	0.342		
		Green x	0.250	0.280	0.310		
		Green y	0.632	0.662	0.692		
		Blue x	0.120	0.150	0.180		
		Blue y	0.020	0.050	0.080		
		White x	0.283	0.313	0.343		
		White y	0.299	0.329	0.359		
Color Gamut	%			87			

Note 1: Measurement method

Equipment Pattern Generator, Power Supply, Digital Voltmeter, Luminance meter (SR\_3 or equivalent)

Aperture 1° with 50cm viewing distance

Test Point Center

Environment < 1 lux

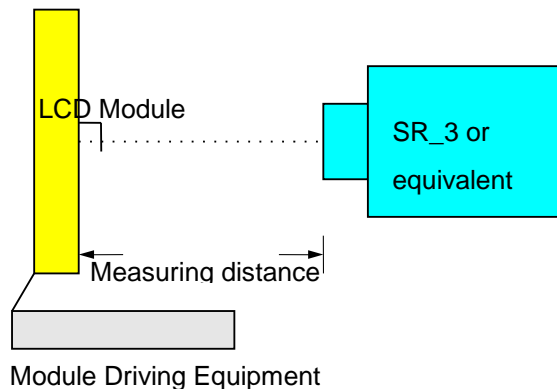

Note 2: Definition of 9 points position

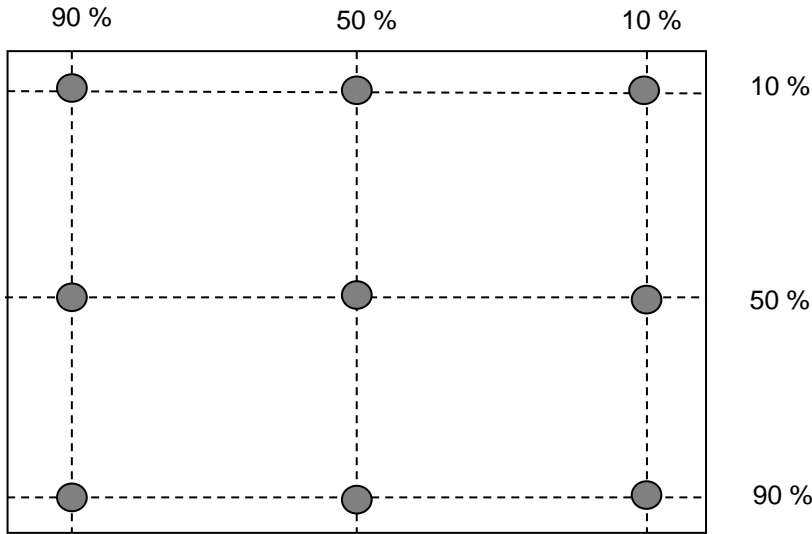

Note 3: Definition of luminance uniformity of 9 points.

$$\delta_{w9} = \frac{|B_{\max} \text{ or } B_{\min} - B_{\text{avg}}|}{B_{\text{avg}}} \times 100\%$$

Note 4: Definition of contrast ratio (CR):

$$\text{Contrast ratio (CR)} = \frac{\text{Brightness on the "White" state}}{\text{Brightness on the "Black" state}}$$

Note 5: Definition of response time:

The output signals of photo detector are measured when the input signals are changed from "White" to "Black" (falling time) and from "Black" to "White" (rising time), respectively. The response time interval is between 10% and 90% of amplitudes. Please refer to the figure as below.

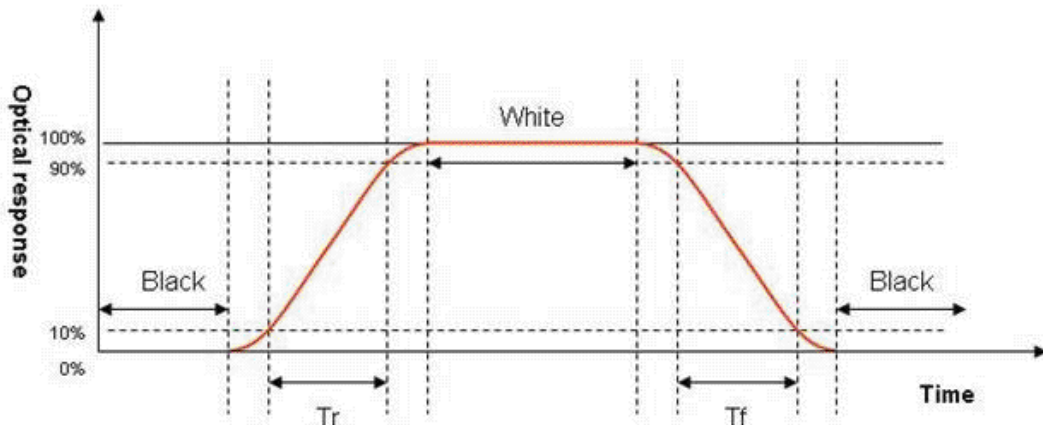

Note 6: Definition of viewing angle

Viewing angle is the measurement of contrast ratio  $\geq 10$ , at the screen center, over a  $180^\circ$  horizontal and  $180^\circ$  vertical range (off-normal viewing angles). The  $180^\circ$  viewing angle range is broken down as below:  $90^\circ$  ( $\theta$ ) horizontal left and right, and  $90^\circ$  ( $\phi$ ) vertical high (up) and low (down). The measurement direction is typically perpendicular to the display surface with the screen rotated to its center to develop the desired measurement viewing angle.

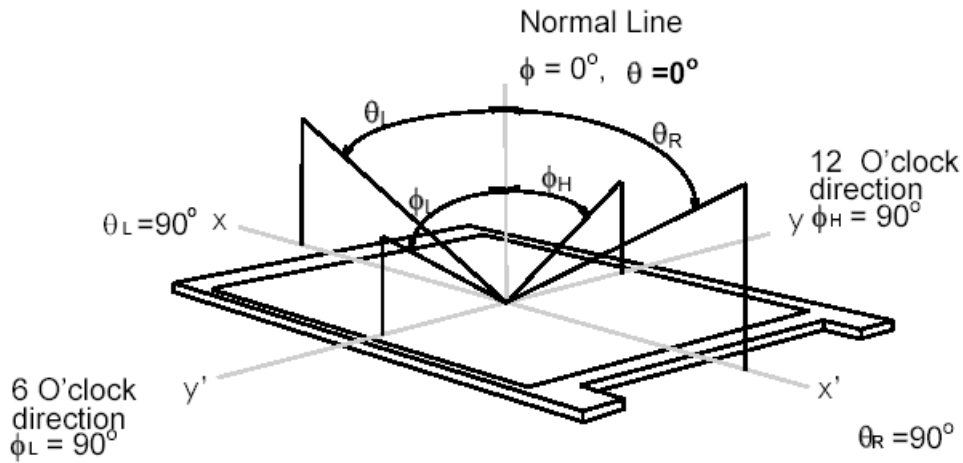



## 3. Functional Block Diagram

The following diagram shows the functional block of the 27 inch color TFT/LCD module:

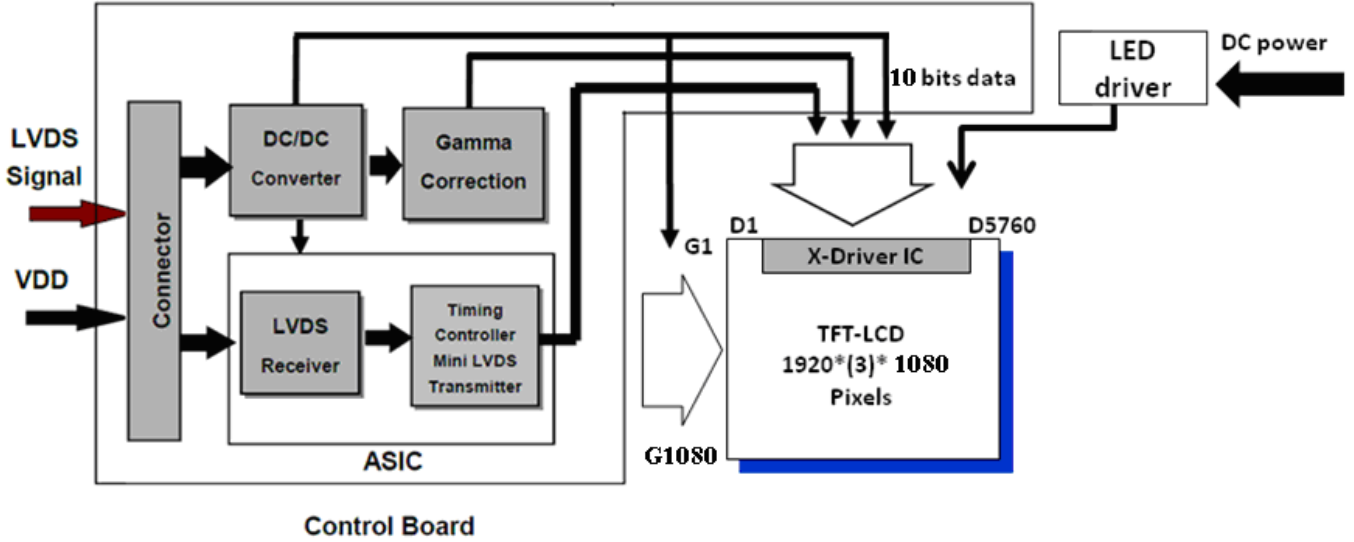

## 4. Absolute Maximum Ratings

### 4.1 Absolute Ratings of TFT LCD Module

Item	Symbol	Min.	Max.	Unit	Conditions
Logic/LCD Drive Voltage	VDD	-0.3	+23	[Volt]	Note 1, 2

### 4.2 Absolute Ratings of Environment

Item	Symbol	Min.	Max.	Unit	Conditions
Operating	TOP	0	+50	[°C]	Note
Operation Humidity	HOP	5	90	[%RH]	
Storage	TST	-20	+60	[°C]	
Storage Humidity	HST	5	90	[%RH]	



Note 1: With in Ta= 25°C

Note 2: Permanent damage to the device may occur if exceed maximum values

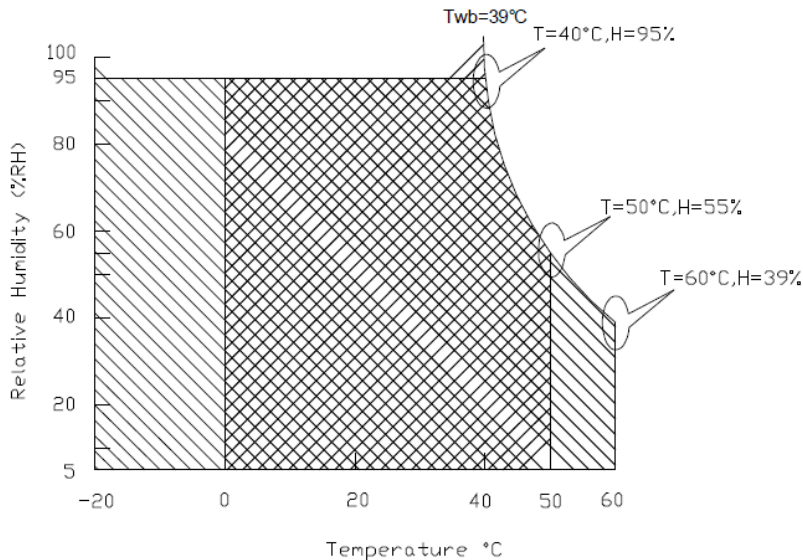
Note 3: For quality performance, please refer to AUO IIS (Incoming Inspection Standard).



Operating Range 

Storage Range  + 

## 5. Electrical Characteristics

### 5.1 TFT LCD Module

#### 5.1.1 Power Specification

Input power specifications are shown as follows;

Symbol	Parameter	Min	Typ	Max	Units	Remark
VDD	Logic/LCD Drive Voltage	10.8	12.0	13.2	[Volt]	± 10%
IDD	VDD Current	-	0.2	0.5	[A]	V <sub>in</sub> =12V, White Pattern, at 60Hz
I <sub>rush</sub>	LCD Inrush Current	-	2.7	3.4	[A]	Note 1
PDD	VDD Power	-	2.4	6	[Watt]	V <sub>in</sub> =12V, White Pattern, at 60Hz
VDD <sub>rp</sub>	Allowable Logic/LCD Drive Ripple Voltage	-	-	300	[mV] p-p	With panel loading

Note 1: Measurement condition:

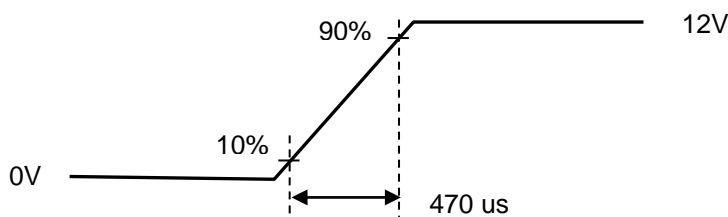
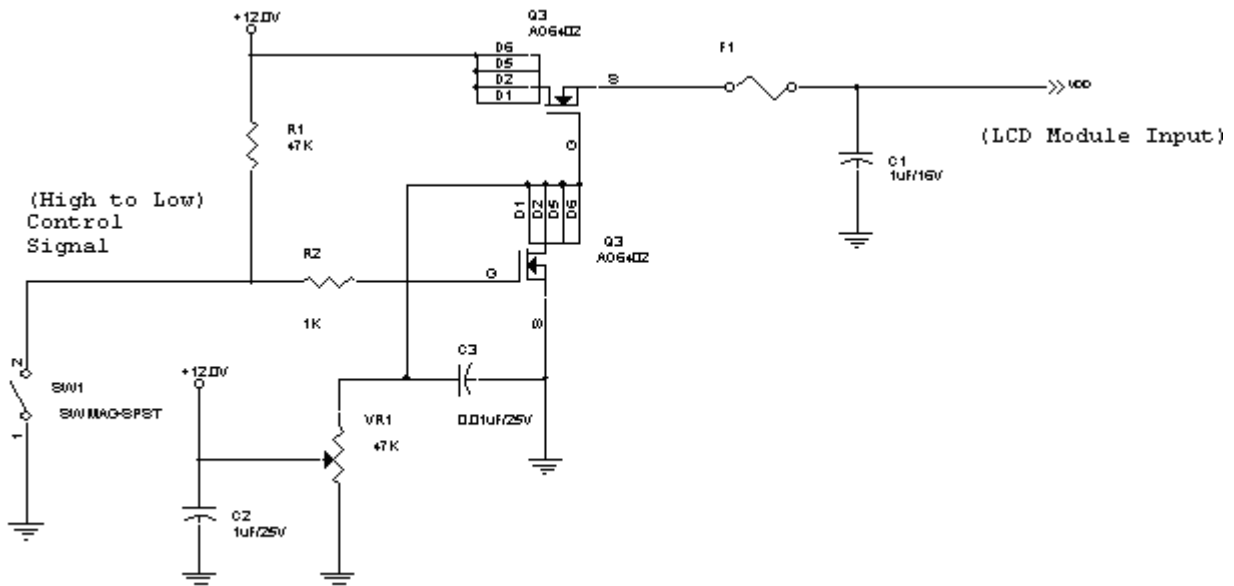

VDD rising time

## 5.1.2 LVDS DC Signal Electrical Characteristics

Input signals shall be low or Hi-Z state when VDD is off.

Symbol	Item	Min.	Typ.	Max.	Unit	Remark
V <sub>TH</sub>	Differential Input High Threshold	-	-	+100	[mV]	V <sub>CM</sub> =1.2V
V <sub>TL</sub>	Differential Input Low Threshold	-100	-	-	[mV]	V <sub>CM</sub> =1.2V
VID	Input Differential Voltage	100	-	600	[mV]	
V <sub>ICM</sub>	Differential Input Common Mode Voltage	+1.0	+1.2	+1.5	[V]	V <sub>TH</sub> /V <sub>TL</sub> =±200mV

Note: LVDS Signal Waveform.

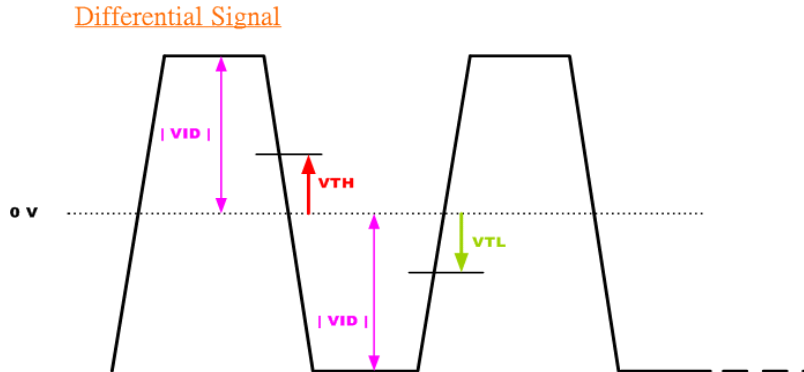
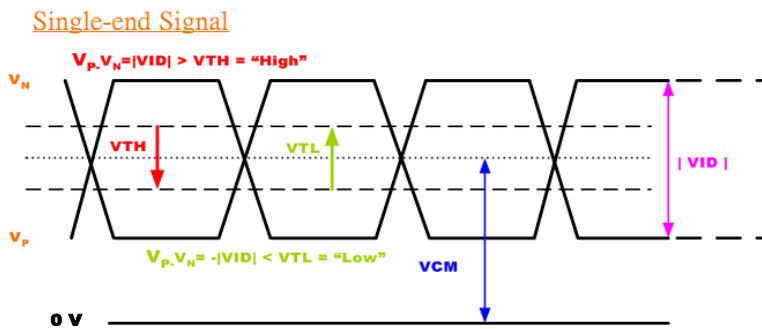

## 5.2 Backlight Unit

### 5.2.1 LED Backlight Unit : Driver Connector

Backlight	manufacturer	JST
	part number	S14B-PH-SM6-K-TB(HF)
Mating	manufacturer	JST
	part number	PHR-14

Pin #	Symbol	Pin Description
1	VDD	Power +24V
2	VDD	Power +24V
3	VDD	Power +24V
4	VDD	Power +24V
5	VDD	Power +24V
6	GND	GND
7	GND	GND
8	GND	GND
9	GND	GND
10	GND	GND
11	NC	Do not connect
12	EN	Enable(0V:disable, 2.5~5V:Enable)
13	Dimming	PWM; duty 10%~ 100%
14	NC	Do not connect

## 5.2.2 Parameter guideline for LED

Following characteristics are measured under a stable condition using an inverter at 25°C (Room Temperature):

### LED characteristics

Symbol	Parameter	Min	Typ	Max	Units	Condition
PLED	LED Power Consumption	-	35.1	39.78	Watt	IF =65 mA, Ta = 25°C LBx2 : 17.55x2=35.1(typ)
LTLED	LED Lifetime	50,000			Hrs	IF =65 mA, Ta= 25°C

Note 1: Calculator value for reference PLED = VF (Normal Distribution) \* IF (Normal Distribution) / Efficiency

Note 2: The LED life-time is estimated data. And is defined when a single LED operated in room temperature, the estimated time to 50% degradation of initial luminous.

### Backlight input signal characteristics

Symbol	Parameter	Min.	Typ.	Max.	Unit	Remark
VDD	Input Voltage	22.8	24	25.2	[Volt]	±5%
I <sub>VDD</sub>	Input Current	--	1.72	1.95	[A]	100% PWM Duty
P <sub>VDD</sub>	Power Consumption	--	41.29	46.8	[Watt]	100% PWM Duty
I <sub>rush LED</sub>	Inrush Current			6	[A]	at rising time=470us
F <sub>PWM</sub>	Dimming Frequency		0.2	20	[kHz]	
	Swing Voltage	3	3.3	5	V	
	Dimming Duty Cycle	10	-	100	%	
I <sub>F</sub>	LED Forward Current		65		mA	Ta = 25°C
V <sub>F</sub>	LED Forward Voltage (Per light-bar)	-	-	-	Volt	
		-	27	30.6	Volt	IF =65 mA, Ta = 25°C Single light-bar is 10 strings x 9pcs/ per string 2 light-bars/per panel

Note1: Measured on panel VLED

## 6. Signal Characteristic

### 6.1 Pixel Format Image

Following figure shows the relationship between input signal and LCD pixel format.

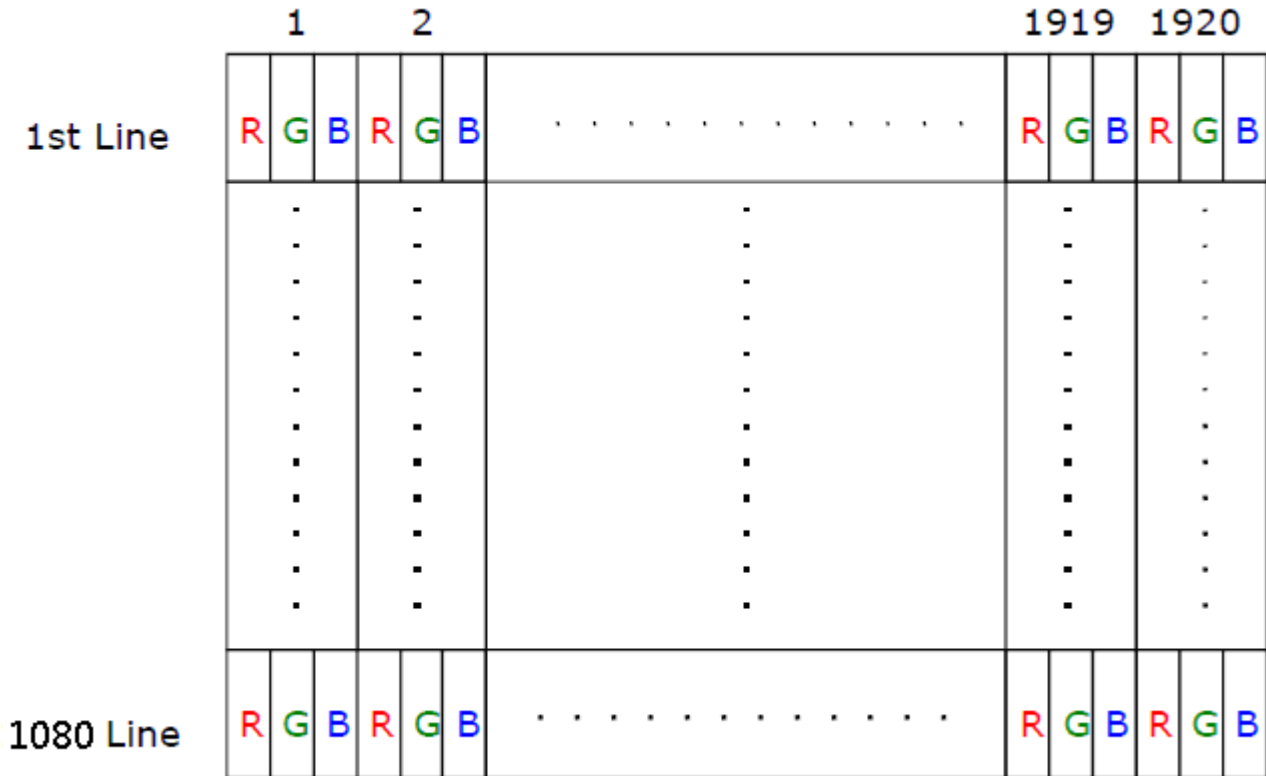

### 6.2 Scanning Direction

The following figures show the image seen from the front view. The arrow indicates the direction of scan.

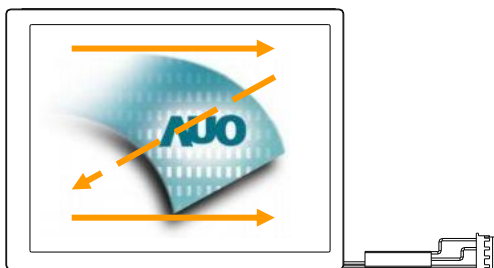

## 6.3 Signal Description

The module using a pair of LVDS receiver SN75LVDS82(Texas Instruments) or compatible. LVDS is a differential signal technology for LCD interface and high speed data transfer device. Transmitter shall be SN75LVDS83(negative edge sampling) or compatible. The first LVDS port(RxOxxx) transmits odd pixels while the second LVDS port(RxExxx) transmits even pixels.

### 6.3.1 TFT LCD Module: LVDS Connector

<b>LCD</b>	manufacturer	JAE
	part number	FI-RE51S-HF-R1500
<b>Mating</b>	manufacturer	JAE
	part number	FI-RE51HL

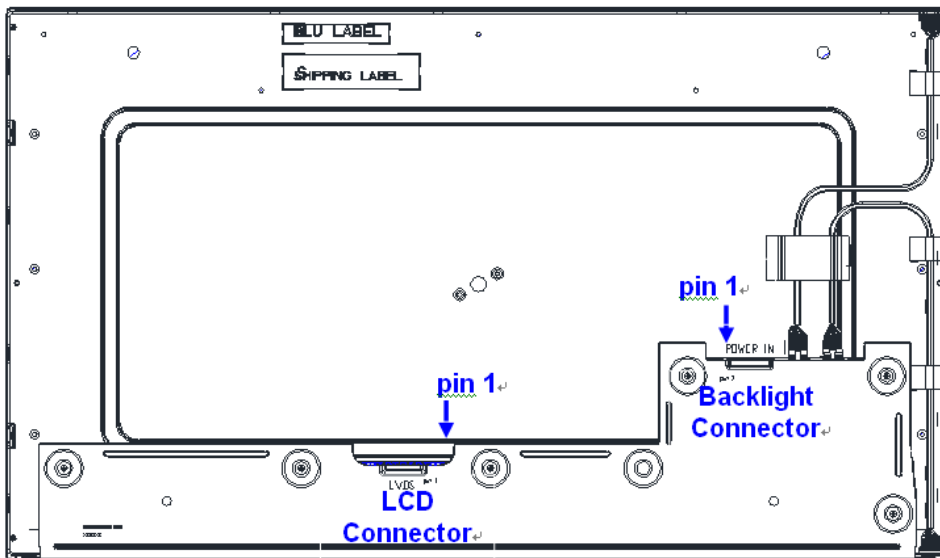



## 6.3.2 Connector Pin Assignment

PIN #	Symbol	PIN #	Symbol
1	GND	27	GND
2	NC	28	RE0N
3	NC	29	RE0P
4	NC	30	RE1N
5	NC	31	RE1P
6	NC	32	RE2N
7	GND	33	RE2P
8	NC	34	GND
9	NC	35	RECLKN
10	NC	36	RECLKP
11	GND	37	GND
12	RO0N	38	RE3N
13	RO0P	39	RE3P
14	RO1N	40	RE4N
15	RO1P	41	RE4P
16	RO2N	42	GND
17	RO2P	43	GND
18	GND	44	GND
19	ROCLKN	45	GND
20	ROCLKP	46	GND
21	GND	47	NC
22	RO3N	48	VDD
23	RO3P	49	VDD
24	RO4N	50	VDD
25	RO4P	51	VDD
26	GND		

## 6.4 The Input Data Format

Data Mapping of JEIDA Format

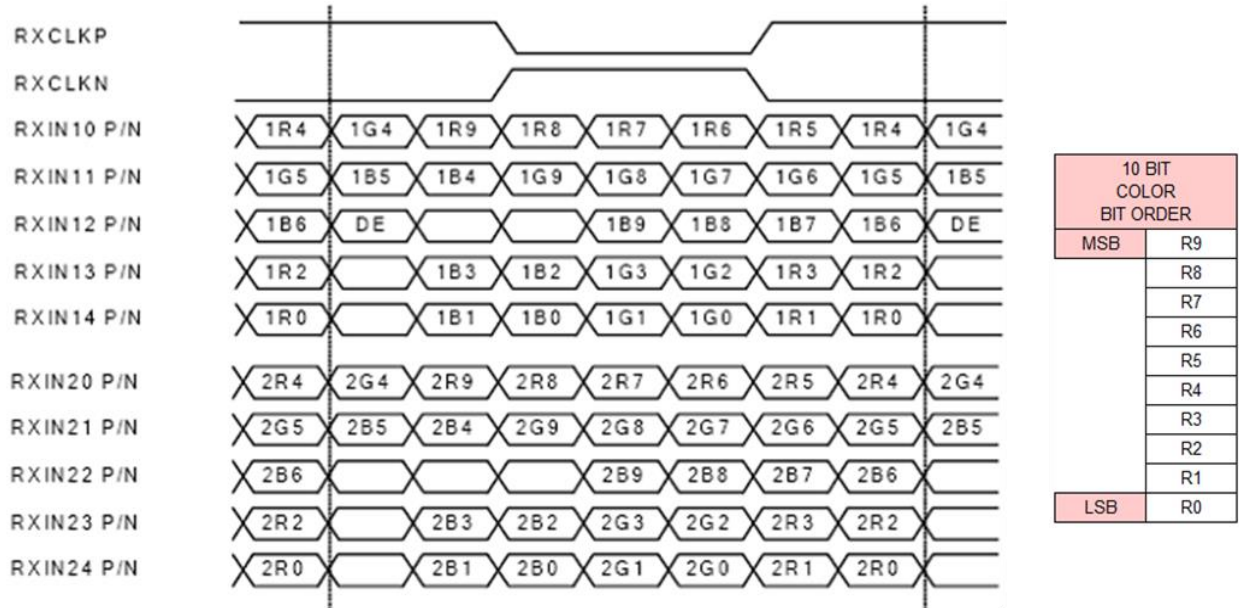

Note1: Normally DE mode only. VS and HS on EVEN channel are not used.

Note2: Please follow VESA.

Note3: 10-bit in

## 6.5 Interface Timing

### 6.5.1 Timing Characteristics

Symbol	Description		Min.	Typ.	Max.	Unit
Tv	Vertical Section	Period	1094	1130	1836	Th
Tdisp (v)		Active	1080	1080	1080	Th
Tblk (v)		Blanking	14	50	756	Th
Fv		Frequency	49	60	76	Hz
Th	Horizontal Section	Period	1000	1050	1678	Tclk
Tdisp (h)		Active	960	960	960	Tclk
Tblk (h)		Blanking	40	90	718	Tclk
Fh		Frequency	53.7	67.8	90.0	KHz
Tclk	LVDS Clock	Period	11.2	14.0	18.6	ns
Fclk		Frequency	53.7	71.2	90.0	MHz

#### DE mode only

**Note 1-1:** The equation is listed as following. Please don't exceed the above recommended value.

$$\begin{aligned} Fh (\text{Min.}) &= Fclk (\text{Min.}) / Th (\text{Min.}); \\ Fh (\text{Typ.}) &= Fclk (\text{Typ.}) / Th (\text{Typ.}); \\ Fh (\text{Max.}) &= Fclk (\text{Max.}) / Th (\text{Min.}); \end{aligned}$$

**Note 1-2:** The equation is listed as following. Please don't exceed the above recommended value.

$$\begin{aligned} Fclk (\text{Min.}) &= Fv (\text{Min.}) \times Th (\text{Min.}) \times Tv (\text{Min.}); \\ Fclk (\text{Typ.}) &= Fv (\text{Typ.}) \times Th (\text{Typ.}) \times Tv (\text{Typ.}); \\ Fclk (\text{Max.}) &= Fv (\text{Max.}) \times Th (\text{Typ.}) \times Tv (\text{Typ.}); \end{aligned}$$

## 6.5.2 Input Timing Diagram

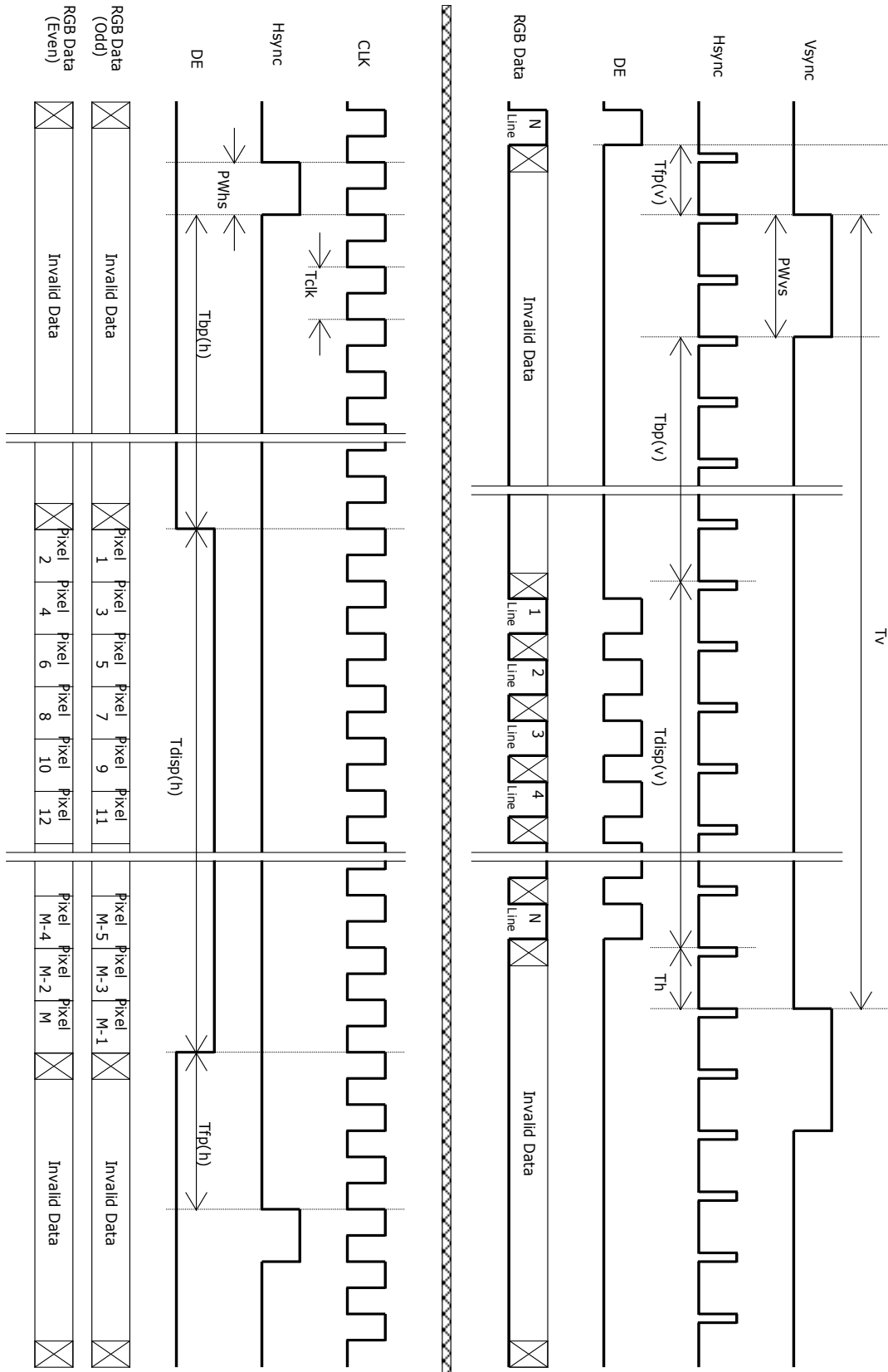

## 6.6 Power ON/OFF Sequence

VDD power and lamp on/off sequence is as below. Interface signals are also shown in the chart. Signals from any system shall be Hi-Z state or low level when VDD is off.

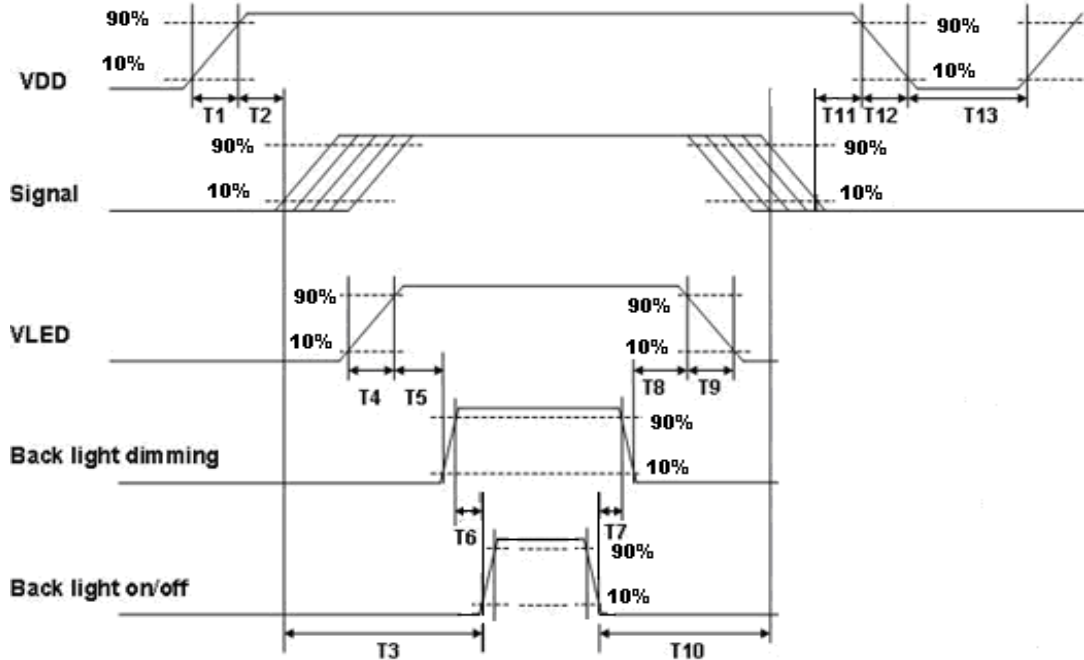

### Power ON/OFF sequence timing

Parameter	Value			Units
	Min.	Typ.	Max.	
T1	0.5	-	10	[ms]
T2	30	40	50	[ms]
T3	200	-	--	[ms]
T4	0.5	-	10	[ms]
T5	10	-	-	[ms]
T6	10	-	-	[ms]
T7	0	-	-	[ms]
T8	10	-	-	[ms]
T9	-	-	10	[ms]
T10	110	-	-	[ms]
T11	0	16	50	[ms]
T12	0	-	10	[ms]
T13	1000	-	-	[ms]

The above on/off sequence should be applied to avoid abnormal function in the display. Please make sure to turn off the power when you plug the cable into the input connector or pull the cable out of the connector.

## 7. Reliability Test Criteria

Items	Required Condition	Note
Temperature Humidity Bias (THB)	Ta= 50°C, 80%RH, 300hours	
High Temperature Operation (HTO)	Ta= 50°C, 300hours	
Low Temperature Operation (LTO)	Ta= 0°C, 300hours	
High Temperature Storage (HTS)	Ta= 60°C, 300hours	
Low Temperature Storage (LTS)	Ta= -20°C, 300hours	
Vibration Test (Non-operation)	Acceleration: 1.5 G Wave: Random Frequency: 10 - 200 Hz Sweep: 30 Minutes each Axis (X, Y, Z)	
Shock Test (Non-operation)	Acceleration: 50 G Wave: Half-sine Active Time: 20 ms Direction: ±X, ±Y, ±Z (one time for each Axis)	
Drop Test	Height: 60 cm, package test	
Thermal Shock Test (TST)	-20 °C /30min, 60/°C 30min, 100 cycles	1
On/Off Test	On/10sec, Off/10sec, 30,000 cycles	
ESD (Electrostatic Discharge)	Contact Discharge: ± 8KV, 150pF(330Ω ) 1sec, 9 points, 25 times/ point.	2
	Air Discharge: ± 15KV, 150pF(330Ω ) 1sec 9 points, 25 times/ point.	
Altitude Test	Operation:10,000 ft	
	Non-Operation:30,000 ft	

Note 1: The TFT-LCD module will not sustain damage after being subjected to 100 cycles of rapid temperature change. A cycle of rapid temperature change consists of varying the temperature from -20°C to 50°C, and back again. Power is not applied during the test. After temperature cycling, the unit is placed in normal room ambient for at least 4 hours before power on.

Note 2: According to EN61000-4-2 , ESD class B: Some performance degradation allowed. No data lost. Self-recoverable. No hardware failures.

Note 3:

- Water condensation is not allowed for each test items.
- Each test is done by new TFT-LCD module. Don't use the same TFT-LCD module repeatedly for reliability test.
- The reliability test is performed only to examine the TFT-LCD module capability.
- To inspect TFT-LCD module after reliability test, please store it at room temperature and room humidity for 24 hours at least in advance.
- No function failure occurs. Mura shall be ignored after high temperature reliability test.

## 8. Mechanical Characteristics

### 8.1 LCM Outline Dimension

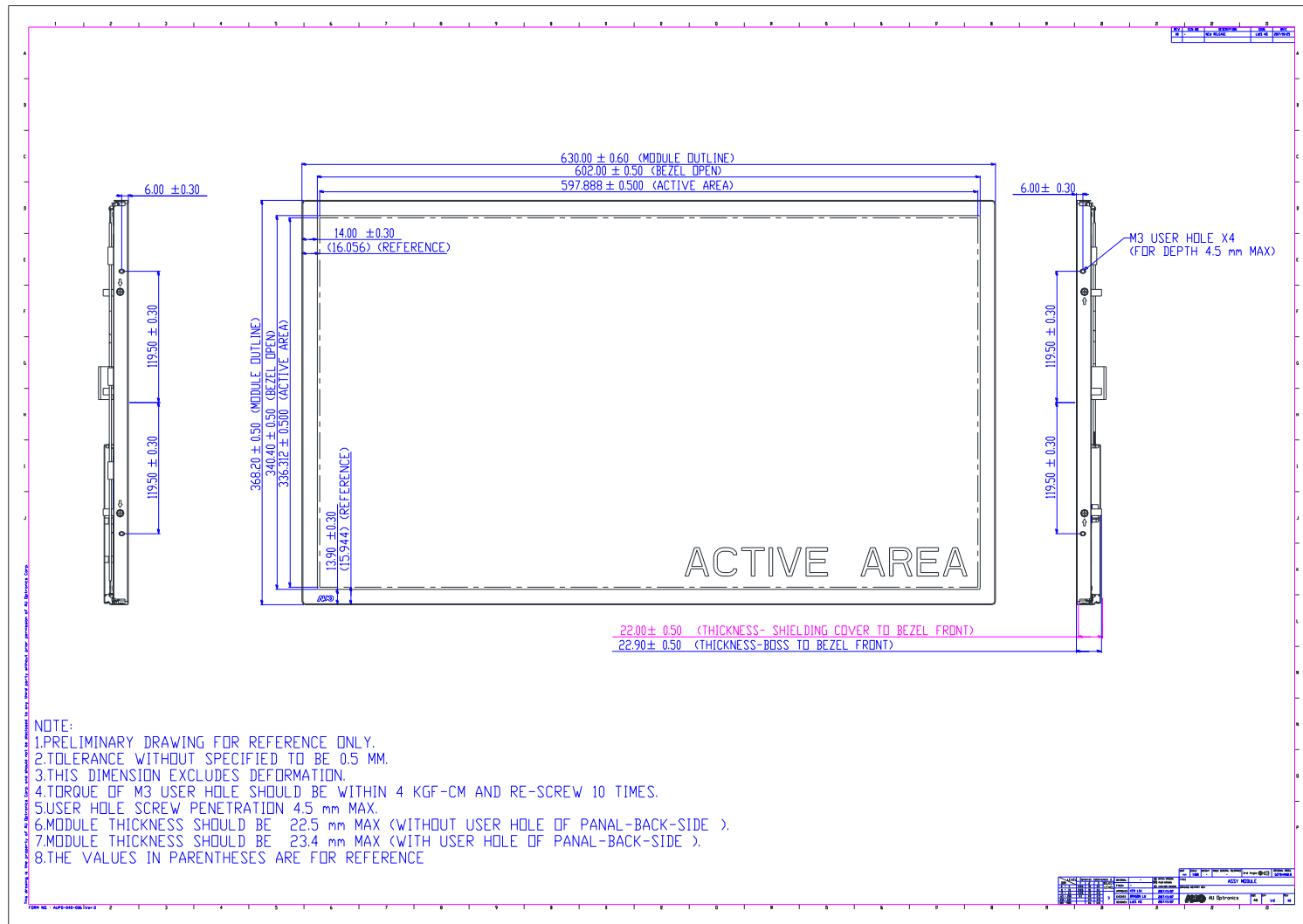

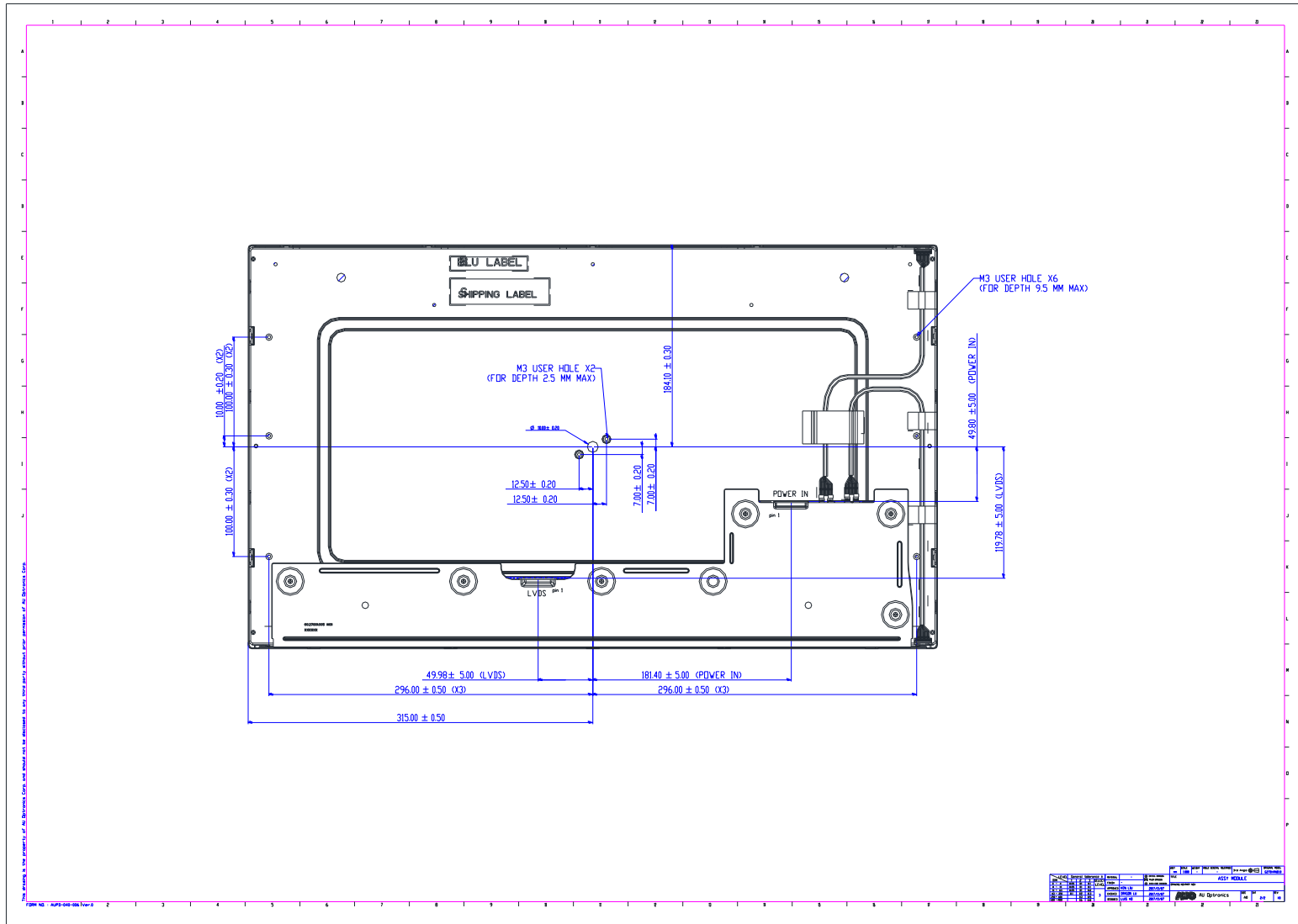



## 9. Label and Packaging

### 9.1 Shipping Label (on the rear side of TFT-LCD display)



Note 1: For Pb Free products, AUO will add for identification.

Note 2: For RoHS compatible products, AUO will add for identification.

Note 3: For China RoHS compatible products, AUO will add for identification.

Note 4: The Green Mark will be presented only when the green documents have been ready by AUO Internal Green Team.

### 9.2 Carton Package

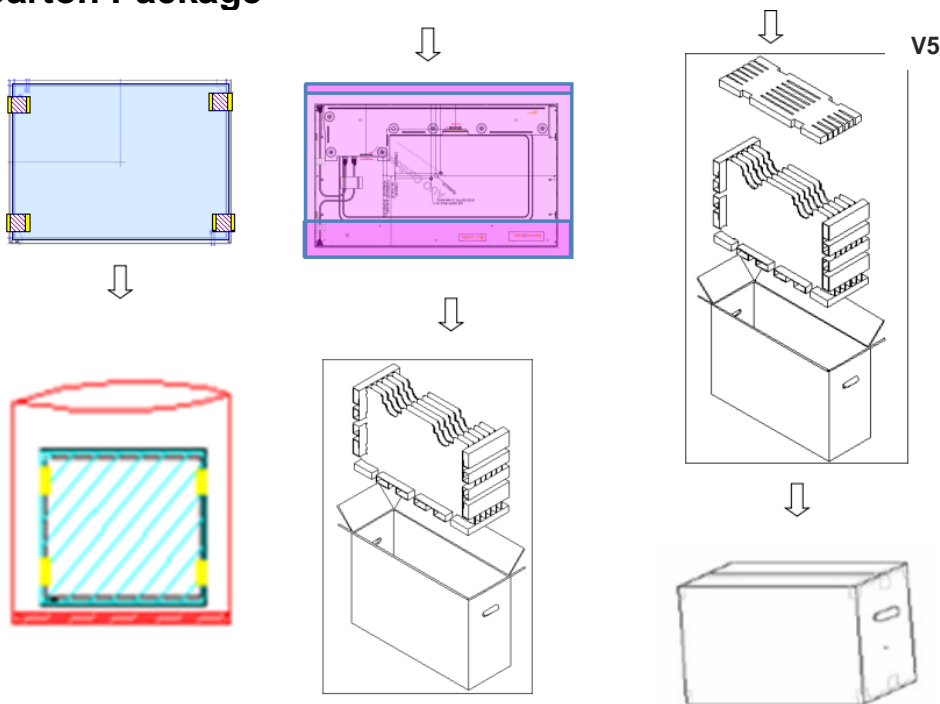

Max capacity : 5 PCS TFT-LCD module per carton

Max weight: 20 kg per carton

Outside dimension of carton: 730mm(L)\* 270mm(W)\*470mm(H)

Pallet size : 1200 mm \* 800 mm \* 132mm

Box stacked

Module by air\_Max : (1 \*4) \*3 layers , one pallet put 12 boxes , total 60pcs module

Module by sea\_Max : (1\*4) \*3 layers + (1 \*4) \*1 layers , two pallet put 16 boxes , total 80pcs module

Module by sea\_HQ\_Max : (1\*4) \*3 layers+(1\*4) \*1 layers, two pallet put 16 boxes, total 80pcs module



## **10 Safety**

### **10.1 Sharp Edge Requirements**

There will be no sharp edges or comers on the display assembly that could cause injury.

### **10.2 Materials**

#### **10.2.1 Toxicity**

There will be no carcinogenic materials used anywhere in the display module. If toxic materials are used, they will be reviewed and approved by the responsible AUO toxicologist.

#### **10.2.2 Flammability**

All components including electrical components that do not meet the flammability grade UL94-V1 in the module will complete the flammability rating exception approval process. The printed circuit board will be made from material rated 94-V1 or better. The actual UL flammability rating will be printed on the printed circuit board.

### **10.3 Capacitors**

If any polarized capacitors are used in the display assembly, provisions will be made to keep them from being inserted backwards.

### **10.4 National Test Lab Requirement**

The display module will satisfy all requirements for compliance to:

UL 60950-1 second edition

U.S.A. Information Technology Equipment