

Doc. Number :

- Tentative Specification
- Preliminary Specification
- Approval Specification

MODEL NO.: M215HJJ
SUFFIX: L30

Customer: Common Model	
APPROVED BY	SIGNATURE
Name / Title _____	_____
Note	
Product version C5/C6	
Please return 1 copy for your confirmation with your signature and comments.	

Approved By	Checked By	Prepared By
陳立錚	徐煥效	張剛

CONTENTS

1. GENERAL DESCRIPTION	5
1.1 OVERVIEW	5
1.2 GENERAL SPECIFICATIONS	5
2. MECHANICAL SPECIFICATIONS	5
3. ABSOLUTE MAXIMUM RATINGS	6
3.1 ABSOLUTE RATINGS OF ENVIRONMENT	6
3.2 ELECTRICAL ABSOLUTE RATINGS	6
3.2.1 TFT LCD MODULE	6
3.2.2 BACKLIGHT UNIT	7
4. ELECTRICAL SPECIFICATIONS	8
4.1 FUNCTION BLOCK DIAGRAM	8
4.2. INTERFACE CONNECTIONS	9
4.3 ELECTRICAL CHARACTERISTICS	11
4.3.1 LCD ELETRONICS SPECIFICATION	11
4.3.2 VCC POWER DIP CONDITION	14
4.3.3 BACKLIGHT UNIT	14
4.3.4 LIGHTBAR CONNECTOR PIN ASSIGNMENT	15
4.4 LVDS INPUT SIGNAL SPECIFICATIONS	16
4.4.1 LVDS DATA MAPPING TABLE	16
4.4.2 COLOR DATA INPUT ASSIGNMENT	17
4.5 DISPLAY TIMING SPECIFICATIONS	18
4.6 POWER ON/OFF SEQUENCE	21
5. OPTICAL CHARACTERISTICS	23
5.1 TEST CONDITIONS	23
5.2 OPTICAL SPECIFICATIONS	23
6. RELIABILITY TEST ITEM	26
7. MECHANICAL STRENGTH CHARACTERISTICS	27
7.1 MECHANICAL STRENGTH SPECIFICATIONS	27
7.2 TEST CONDITIONS	27
7.3 DEFINITION OF TEST POINTS	27
8. PACKING	28
8.1 PACKING SPECIFICATIONS	28
8.2 PACKING METHOD	28
8.3 PALLET	29
8.4 UN-PACKING METHOD	30

9. INX MODULE LABEL	31
10. PRECAUTIONS	32
10.1 ASSEMBLY AND HANDLING PRECAUTIONS	32
10.2 STORAGE PRECAUTIONS	32
10.3 OPERATION PRECAUTIONS	33
10.4 SAFETY PRECAUTIONS	33
10.5 SAFETY STANDARDS	33
10.6 OTHER	33
Appendix 1. SYSTEM COVER DESIGN NOTICE	34
Appendix 2. OUTLINE DRAWING	38

REVISION HISTORY

Version	Date	Page	Description																																																																												
3.0	2015.12.29	All	Approval Specification was first issued.																																																																												
3.1	2016.09.12	Page 6	1.2 Power Consumption Total 15.13W@ cell 5.6 W, BL 9.53 (W), → Total 16.42 W@ cell 5.6 W, BL 10.82 (W) MAX,																																																																												
		Page 13	4.3.3 BACKLIGHT UNIT Before <table border="1"> <thead> <tr> <th rowspan="2">Parameter[Ⓢ]</th> <th rowspan="2">Symbol[Ⓢ]</th> <th colspan="3">Value[Ⓢ]</th> <th rowspan="2">Unit[Ⓢ]</th> <th rowspan="2">Note[Ⓢ]</th> </tr> <tr> <th>Min.[Ⓢ]</th> <th>Typ.[Ⓢ]</th> <th>Max.[Ⓢ]</th> </tr> </thead> <tbody> <tr> <td>LED Light Bar Input Voltage Per Input Pin[Ⓢ]</td> <td>VPIN[Ⓢ]</td> <td>32.73[Ⓢ]</td> <td>(36.66)[Ⓢ]</td> <td>(38.35)[Ⓢ]</td> <td>V[Ⓢ]</td> <td>(1)[Ⓢ] Duty=100%[Ⓢ] IPIN=(65mA)[Ⓢ]</td> </tr> <tr> <td>LED Light Bar Current Per Input Pin[Ⓢ]</td> <td>IPIN[Ⓢ]</td> <td>--[Ⓢ]</td> <td>(65)[Ⓢ]</td> <td>(69)[Ⓢ]</td> <td>mA[Ⓢ]</td> <td>(1), (2)[Ⓢ] Duty=100%[Ⓢ]</td> </tr> <tr> <td>LED Life Time[Ⓢ]</td> <td>LLED[Ⓢ]</td> <td>40000[Ⓢ]</td> <td>--[Ⓢ]</td> <td>--[Ⓢ]</td> <td>Hrs[Ⓢ]</td> <td>(3)[Ⓢ]</td> </tr> <tr> <td>Power Consumption[Ⓢ]</td> <td>PBL[Ⓢ]</td> <td>--[Ⓢ]</td> <td>(9.53)[Ⓢ]</td> <td>(9.971)[Ⓢ]</td> <td>W[Ⓢ]</td> <td>(1)[Ⓢ] Duty=100%[Ⓢ] IPIN=(65mA)[Ⓢ]</td> </tr> </tbody> </table> After <table border="1"> <thead> <tr> <th rowspan="2">Parameter[Ⓢ]</th> <th rowspan="2">Symbol[Ⓢ]</th> <th colspan="3">Value[Ⓢ]</th> <th rowspan="2">Unit[Ⓢ]</th> <th rowspan="2">Note[Ⓢ]</th> </tr> <tr> <th>Min.[Ⓢ]</th> <th>Typ.[Ⓢ]</th> <th>Max.[Ⓢ]</th> </tr> </thead> <tbody> <tr> <td>LED Light Bar Input Voltage Per Input Pin[Ⓢ]</td> <td>VPIN[Ⓢ]</td> <td>33.67[Ⓢ]</td> <td>37.7[Ⓢ]</td> <td>41.6[Ⓢ]</td> <td>V[Ⓢ]</td> <td>(1)[Ⓢ] Duty=100%[Ⓢ] IPIN=65mA[Ⓢ]</td> </tr> <tr> <td>LED Light Bar Current Per Input Pin[Ⓢ]</td> <td>IPIN[Ⓢ]</td> <td>--[Ⓢ]</td> <td>65[Ⓢ]</td> <td>69[Ⓢ]</td> <td>mA[Ⓢ]</td> <td>(1), (2)[Ⓢ] Duty=100%[Ⓢ]</td> </tr> <tr> <td>LED Life Time[Ⓢ]</td> <td>LLED[Ⓢ]</td> <td>40000[Ⓢ]</td> <td>--[Ⓢ]</td> <td>--[Ⓢ]</td> <td>Hrs[Ⓢ]</td> <td>(3)[Ⓢ]</td> </tr> <tr> <td>Power Consumption[Ⓢ]</td> <td>PBL[Ⓢ]</td> <td>--[Ⓢ]</td> <td>9.802[Ⓢ]</td> <td>10.82[Ⓢ]</td> <td>W[Ⓢ]</td> <td>(1)[Ⓢ] Duty=100%[Ⓢ] IPIN=65mA[Ⓢ]</td> </tr> </tbody> </table>	Parameter [Ⓢ]	Symbol [Ⓢ]	Value [Ⓢ]			Unit [Ⓢ]	Note [Ⓢ]	Min. [Ⓢ]	Typ. [Ⓢ]	Max. [Ⓢ]	LED Light Bar Input Voltage Per Input Pin [Ⓢ]	VPIN [Ⓢ]	32.73 [Ⓢ]	(36.66) [Ⓢ]	(38.35) [Ⓢ]	V [Ⓢ]	(1) [Ⓢ] Duty=100% [Ⓢ] IPIN=(65mA) [Ⓢ]	LED Light Bar Current Per Input Pin [Ⓢ]	IPIN [Ⓢ]	-- [Ⓢ]	(65) [Ⓢ]	(69) [Ⓢ]	mA [Ⓢ]	(1), (2) [Ⓢ] Duty=100% [Ⓢ]	LED Life Time [Ⓢ]	LLED [Ⓢ]	40000 [Ⓢ]	-- [Ⓢ]	-- [Ⓢ]	Hrs [Ⓢ]	(3) [Ⓢ]	Power Consumption [Ⓢ]	PBL [Ⓢ]	-- [Ⓢ]	(9.53) [Ⓢ]	(9.971) [Ⓢ]	W [Ⓢ]	(1) [Ⓢ] Duty=100% [Ⓢ] IPIN=(65mA) [Ⓢ]	Parameter [Ⓢ]	Symbol [Ⓢ]	Value [Ⓢ]			Unit [Ⓢ]	Note [Ⓢ]	Min. [Ⓢ]	Typ. [Ⓢ]	Max. [Ⓢ]	LED Light Bar Input Voltage Per Input Pin [Ⓢ]	VPIN [Ⓢ]	33.67 [Ⓢ]	37.7 [Ⓢ]	41.6 [Ⓢ]	V [Ⓢ]	(1) [Ⓢ] Duty=100% [Ⓢ] IPIN=65mA [Ⓢ]	LED Light Bar Current Per Input Pin [Ⓢ]	IPIN [Ⓢ]	-- [Ⓢ]	65 [Ⓢ]	69 [Ⓢ]	mA [Ⓢ]	(1), (2) [Ⓢ] Duty=100% [Ⓢ]	LED Life Time [Ⓢ]	LLED [Ⓢ]	40000 [Ⓢ]	-- [Ⓢ]	-- [Ⓢ]	Hrs [Ⓢ]	(3) [Ⓢ]	Power Consumption [Ⓢ]	PBL [Ⓢ]	-- [Ⓢ]	9.802 [Ⓢ]	10.82 [Ⓢ]	W [Ⓢ]	(1) [Ⓢ] Duty=100% [Ⓢ] IPIN=65mA [Ⓢ]
Parameter [Ⓢ]	Symbol [Ⓢ]	Value [Ⓢ]				Unit [Ⓢ]	Note [Ⓢ]																																																																								
		Min. [Ⓢ]	Typ. [Ⓢ]	Max. [Ⓢ]																																																																											
LED Light Bar Input Voltage Per Input Pin [Ⓢ]	VPIN [Ⓢ]	32.73 [Ⓢ]	(36.66) [Ⓢ]	(38.35) [Ⓢ]	V [Ⓢ]	(1) [Ⓢ] Duty=100% [Ⓢ] IPIN=(65mA) [Ⓢ]																																																																									
LED Light Bar Current Per Input Pin [Ⓢ]	IPIN [Ⓢ]	-- [Ⓢ]	(65) [Ⓢ]	(69) [Ⓢ]	mA [Ⓢ]	(1), (2) [Ⓢ] Duty=100% [Ⓢ]																																																																									
LED Life Time [Ⓢ]	LLED [Ⓢ]	40000 [Ⓢ]	-- [Ⓢ]	-- [Ⓢ]	Hrs [Ⓢ]	(3) [Ⓢ]																																																																									
Power Consumption [Ⓢ]	PBL [Ⓢ]	-- [Ⓢ]	(9.53) [Ⓢ]	(9.971) [Ⓢ]	W [Ⓢ]	(1) [Ⓢ] Duty=100% [Ⓢ] IPIN=(65mA) [Ⓢ]																																																																									
Parameter [Ⓢ]	Symbol [Ⓢ]	Value [Ⓢ]			Unit [Ⓢ]	Note [Ⓢ]																																																																									
		Min. [Ⓢ]	Typ. [Ⓢ]	Max. [Ⓢ]																																																																											
LED Light Bar Input Voltage Per Input Pin [Ⓢ]	VPIN [Ⓢ]	33.67 [Ⓢ]	37.7 [Ⓢ]	41.6 [Ⓢ]	V [Ⓢ]	(1) [Ⓢ] Duty=100% [Ⓢ] IPIN=65mA [Ⓢ]																																																																									
LED Light Bar Current Per Input Pin [Ⓢ]	IPIN [Ⓢ]	-- [Ⓢ]	65 [Ⓢ]	69 [Ⓢ]	mA [Ⓢ]	(1), (2) [Ⓢ] Duty=100% [Ⓢ]																																																																									
LED Life Time [Ⓢ]	LLED [Ⓢ]	40000 [Ⓢ]	-- [Ⓢ]	-- [Ⓢ]	Hrs [Ⓢ]	(3) [Ⓢ]																																																																									
Power Consumption [Ⓢ]	PBL [Ⓢ]	-- [Ⓢ]	9.802 [Ⓢ]	10.82 [Ⓢ]	W [Ⓢ]	(1) [Ⓢ] Duty=100% [Ⓢ] IPIN=65mA [Ⓢ]																																																																									
3.2	2017.03.15	Page 5	1.2 GENERAL SPECIFICATIONS TCO : TCO 6.0 compliance → TCO 7.0 compliance																																																																												
3.3	2017.07.27	Page 20	5.2 Delete Response time : T _{GtG_AVE} Value																																																																												
		Page 21	Modify Note(3) contents																																																																												
3.4	2017.10.16	Page 17	LVDS Clock Frequency Min 58.54 → 56																																																																												
		Page 17	Vertical Display Term _Total (min.) 1115 → 1105 Vertical Display Term _Total (max.) 1136 → 1251																																																																												
		Page 19	Add Note (5) Please make sure the range of pixel clock has follow the below equation: $F_c(\max) \geq Fr \times Tv \times Th$ $Fr \times Tv \times Th \geq F_c(\min)$																																																																												
		Page 19	Add Note (6) In Free-sync mode, only guaranteed no functional failure, but don't guaranteed its quality of the optical and cosmetic performance																																																																												
3.5	2020.12.3	Page 1	Add Product version C6																																																																												

1. GENERAL DESCRIPTION

1.1 OVERVIEW

M215HJJ-L30 is a 21.5" TFT Liquid Crystal Display MNT module with WLED Backlight unit and 30 pins 2ch-LVDS interface. This module supports 1920 x 1080 Full HD mode and can display up to 16.7M colors. The converter module for Backlight is not built in.

1.2 GENERAL SPECIFICATIONS

Item	Specification	Unit	Note
Screen Size	21.5" real diagonal		
Driver Element	a-si TFT active matrix	-	-
Pixel Number	1920 x R.G.B. x 1080	pixel	-
Pixel Pitch	0.24795 (H) x 0.24795 (V)	mm	-
Pixel Arrangement	RGB vertical stripe	-	-
Display Colors	16.7M	color	-
Transmissive Mode	Normally black	-	-
Surface Treatment	High resolution adaptable AG,3H hard coating, Haze 25%	-	-
Luminance, White	250	Cd/m2	
Color Gamut	72% of NTSC(Typ.)	-	-
Display Orientation	Signal input with " INX"		(2)
TCO	TCO 7.0 compliance		
Power Consumption	Total 16.42 W@ cell 5.6 W, BL 10.82 (W) MAX,		(1)

Note (1) The specified power consumption: Total= cell (reference 4.3.1)+BL (reference 4.3.3)

Note (2)

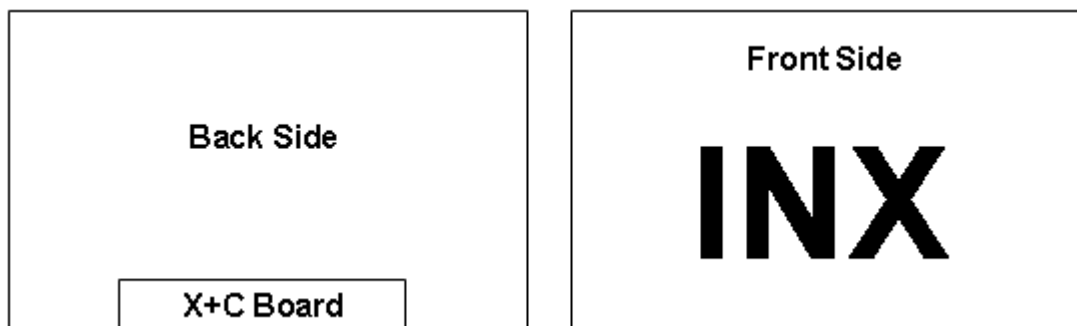

2. MECHANICAL SPECIFICATIONS

Item	Min.	Typ.	Max.	Unit	Note	
Module Size	Horizontal (H)	495.1	495.6	496.1	mm	(1)
	Vertical (V)	291.7	292.2	292.7	mm	
	Thickness (T)	-	11.0	11.5	mm	
Bezel Area	Horizontal	479.34	479.84	480.34	mm	
	Vertical	270.8	271.3	271.8	mm	
Active Area	Horizontal		476.064	-	mm	
	Vertical		267.786	-	mm	
Weight	1620	1800	1890	g		

Note (1) Please refer to the attached drawings for more information of front and back outline dimensions.

3. ABSOLUTE MAXIMUM RATINGS

3.1 ABSOLUTE RATINGS OF ENVIRONMENT

Item	Symbol	Value		Unit	Note
		Min.	Max.		
Storage Temperature	TST	-20	60	°C	(1)
Operating Ambient Temperature	TOP	0	50	°C	(1), (2)

Note (1)

(a) 90 %RH Max..

(b) Wet-bulb temperature should be 39 °C Max.

(c) No condensation.

Note (2) Panel surface temperature should be 0°C min. and 60°C max under Vcc=5.0V, fr =60Hz, typical LED string current, 25°C ambient temperature, and no humidity control . Any condition of ambient operating temperature ,the surface of active area should be keeping not higher than 60°C .

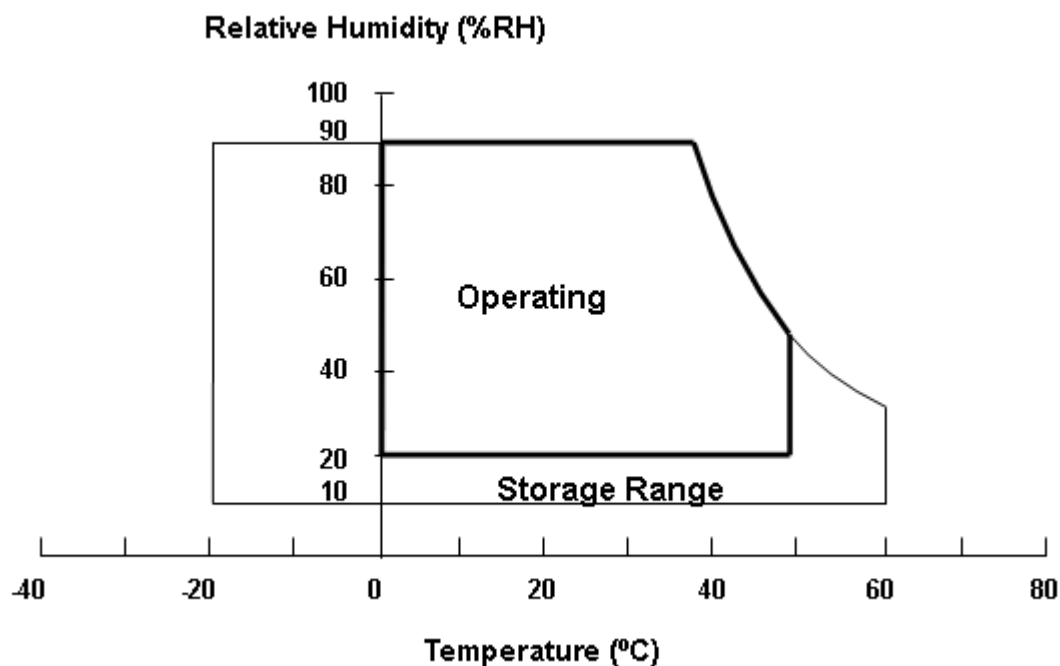

3.2 ELECTRICAL ABSOLUTE RATINGS

3.2.1 TFT LCD MODULE

Item	Symbol	Value		Unit	Note
		Min.	Max.		
Power Supply Voltage	VCCS	-0.3	6.0	V	(1)
Logic Input Voltage	V _{IN}	-0.3	3.6	V	

3.2.2 BACKLIGHT UNIT

Item	Symbol	Value			Unit	Note
		Min.	Typ	Max.		
LED Forward Current Per Input Pin	IF	--	65	69	mA	(1), (2) Duty=100%
LED Pulse Forward Current Per Input Pin	IP	--	--	500	mA	(1), (2) Pulse Width ≤ 10msec. and Duty ≤ 25%

Note (1) Permanent damage to the device may occur if maximum values are exceeded. Function operation should be restricted to the conditions described under Normal Operating Conditions.

Note (2) Specified values are for input pin of LED light bar at Ta=25±2 °C (Refer to 4.3.3 and 4.3.4 for further information).

4. ELECTRICAL SPECIFICATIONS

4.1 FUNCTION BLOCK DIAGRAM

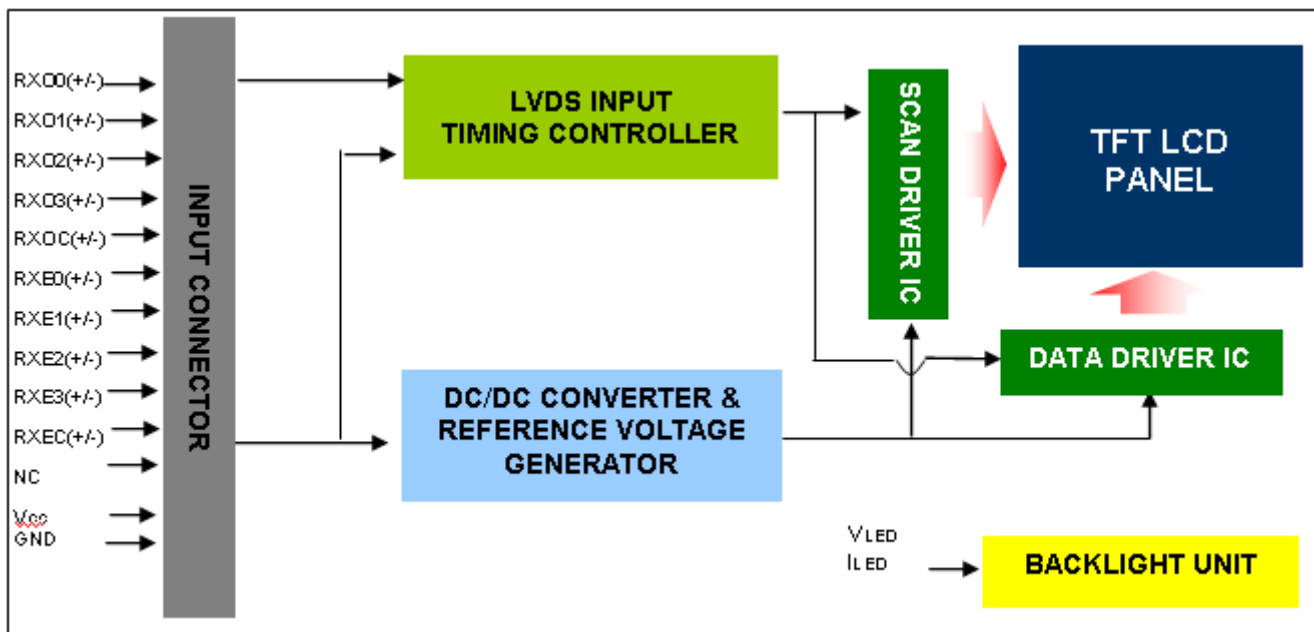

4.2. INTERFACE CONNECTIONS

PIN ASSIGNMENT

Pin	Name	Description
1	RXO0-	Negative LVDS differential data input. Channel O0 (odd)
2	RXO0+	Positive LVDS differential data input. Channel O0 (odd)
3	RXO1-	Negative LVDS differential data input. Channel O1 (odd)
4	RXO1+	Positive LVDS differential data input. Channel O1 (odd)
5	RXO2-	Negative LVDS differential data input. Channel O2 (odd)
6	RXO2+	Positive LVDS differential data input. Channel O2 (odd)
7	GND	Ground
8	RXOC-	Negative LVDS differential clock input. (odd)
9	RXOC+	Positive LVDS differential clock input. (odd)
10	RXO3-	Negative LVDS differential data input. Channel O3(odd)
11	RXO3+	Positive LVDS differential data input. Channel O3 (odd)
12	RXE0-	Negative LVDS differential data input. Channel E0 (even)
13	RXE0+	Positive LVDS differential data input. Channel E0 (even)
14	GND	Ground
15	RXE1-	Negative LVDS differential data input. Channel E1 (even)
16	RXE1+	Positive LVDS differential data input. Channel E1 (even)
17	GND	Ground
18	RXE2-	Negative LVDS differential data input. Channel E2 (even)
19	RXE2+	Positive LVDS differential data input. Channel E2 (even)
20	RXEC-	Negative LVDS differential clock input. (even)
21	RXEC+	Positive LVDS differential clock input. (even)
22	RXE3-	Negative LVDS differential data input. Channel E3 (even)
23	RXE3+	Positive LVDS differential data input. Channel E3 (even)
24	GND	Ground
25	NC	For LCD internal use only, Do not connect
26	NC	For LCD internal use only, Do not connect
27	NC	For LCD internal use only, Do not connect
28	Vcc	+5.0V power supply
29	Vcc	+5.0V power supply
30	Vcc	+5.0V power supply

Note (1) Connector Part No.:

WF13-422-3033(Fullconn) or 187098-30091(P-two) equivalent

Note (2) User's connector Part No:

Mating Wire Cable Connector Part No.: FI-X30H(JAE) or FI-X30HL(JAE)

Mating FFC Cable Connector Part No.: 217007-013001 (P-TWO) or JF05X030-1 (JAE).

*Notice: There would be compatible issues if not using the indicated connectors in the matching list.

Note (3) The first pixel is odd.

Note (4) Input signal of even and odd clock should be the same timing.

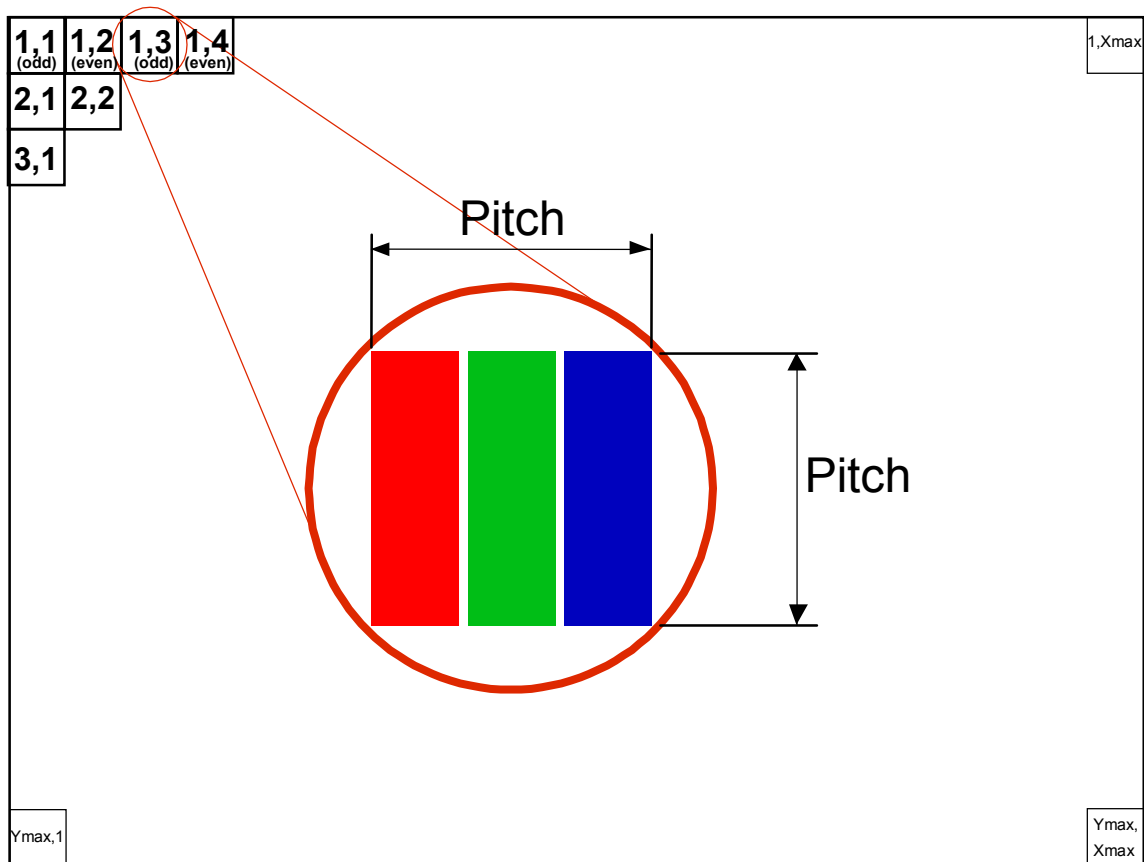

4.3 ELECTRICAL CHARACTERISTICS

4.3.1 LCD ELETRONICS SPECIFICATION

Parameter	Symbol	Value			Unit	Note	
		Min.	Typ.	Max.			
Power Supply Voltage	V _{CC}	4.5	5.0	5.5	V	-	
Ripple Voltage	V _{RP}	-	-	300	mV	-	
Rush Current	I _{RUSH}	-	-	3	A	(2)	
Power Supply Current	White	-	768	910	mA	(3)a	
	Black	-	720	845	mA	(3)b	
	Vertical Stripe	-	948	1105	mA	(3)c	
Power Consumption	PLCD	-	4.8	5.6	Watt	(4)	
LVDS interface	Differential Input Voltage	V _{ID}	100	-	600	mV	
	Common Input Voltage	V _{CM}	1.0	1.2	1.4	V	
	Differential Input High Threshold Voltage	V _{TH}	-	-	+100	mV	
	Differential Input Low Threshold Voltage	V _{TL}	-100	-	-	mV	

Note (1) The ambient temperature is Ta = 25 ± 2 °C.

Note (2) Measurement Conditions:

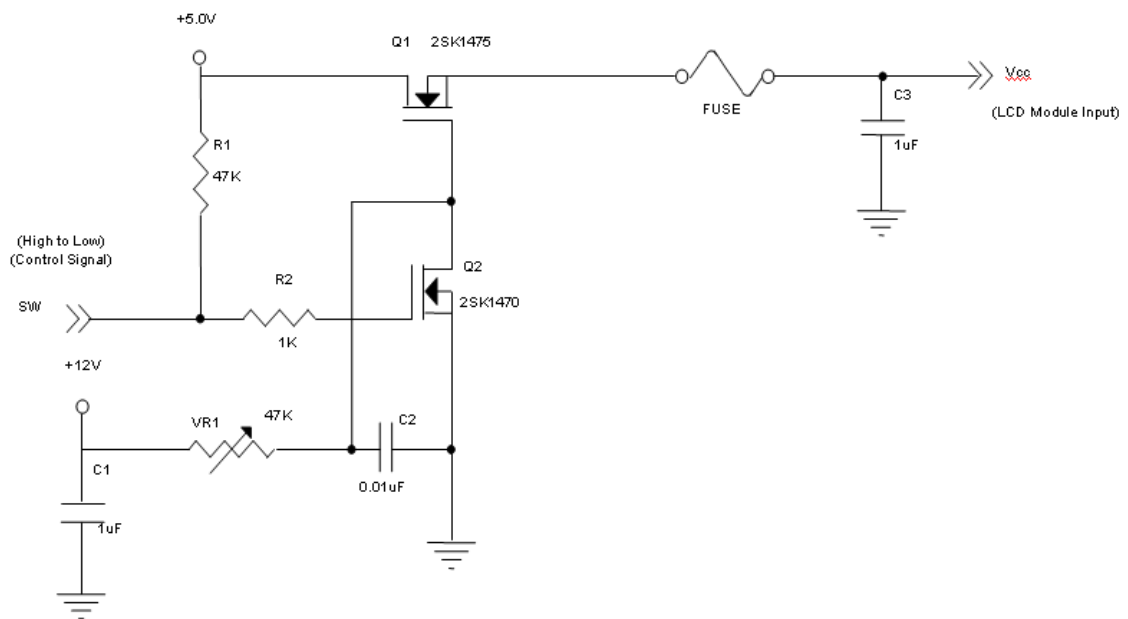

V_{CC} rising time is 470μs

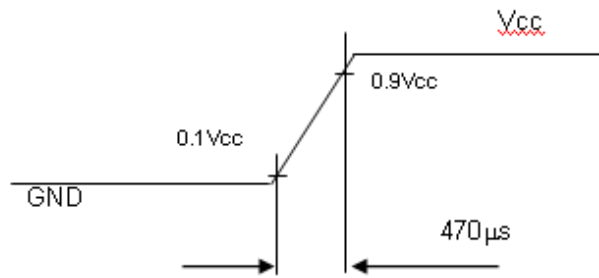

Note (3) The specified power supply current is under the conditions at $V_{CC} = 5.0\text{ V}$, $T_a = 25 \pm 2\text{ }^\circ\text{C}$, $F_r = 60\text{ Hz}$, whereas a power dissipation check pattern below is displayed.

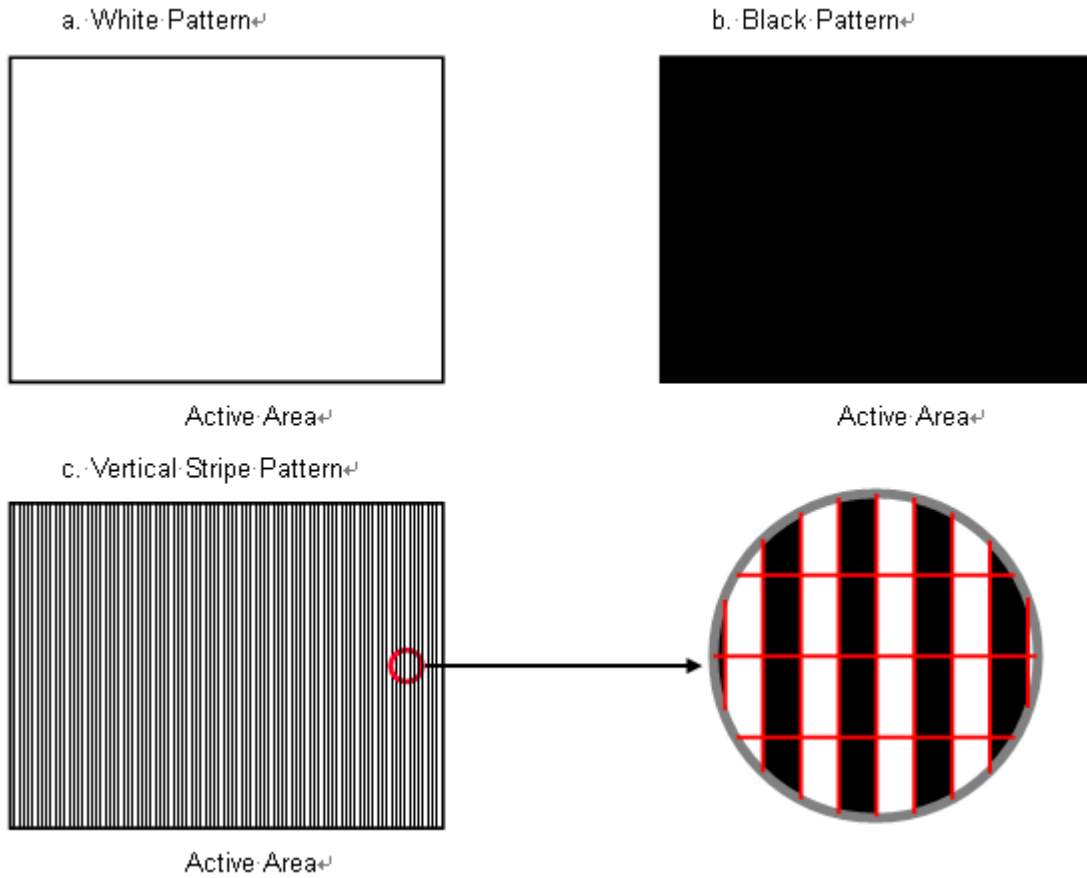

Note (4) The power consumption is specified at the pattern with the maximum current.

Note (5) The LVDS input characteristics are as follows:

Single-end Signals

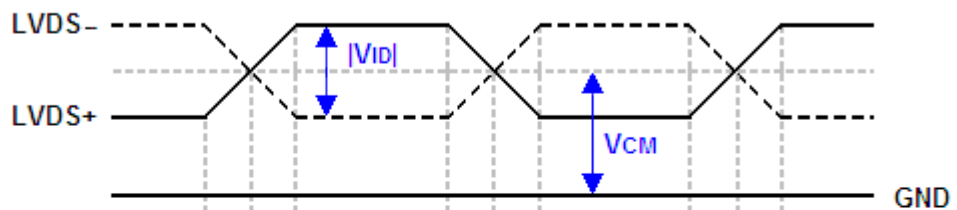

Differential Signal

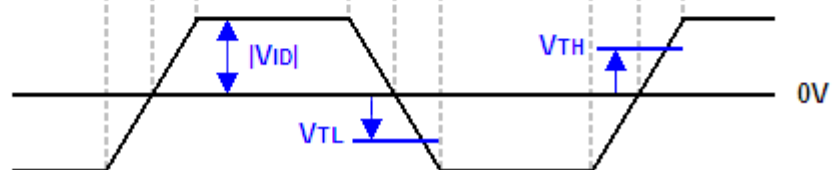

4.3.2 VCC POWER DIP CONDITION

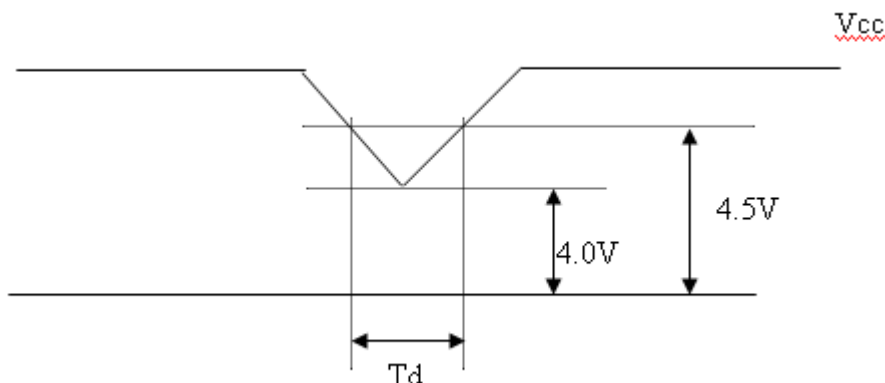

Dip condition: $4.0 \leq V_{cc} \leq 4.5$, $T_d \leq 20\text{ms}$

4.3.3 BACKLIGHT UNIT

Parameter	Symbol	Value			Unit	Note
		Min.	Typ.	Max.		
LED Light Bar Input Voltage Per Input Pin	VPIN	33.67	37.7	41.6	V	(1), Duty=100%, IPIN=65mA
LED Light Bar Current Per Input Pin	IPIN	--	65	69	mA	(1), (2) Duty=100%
LED Life Time	LLED	40000	--	--	Hrs	(3)
Power Consumption	PBL	--	9.802	10.82	W	(1) Duty=100%, IPIN=65mA

Note (1) LED light bar input voltage and current are measured by utilizing a true RMS multimeter as shown below:

Note (2) $PBL(Typ) = IPIN(Typ) \times VPIN(Typ) \times (4)$ $PBL(Max) = IPIN(Typ) \times VPIN(Max) \times (4)$ input pins ,

Note (3) The lifetime of LED is defined as the time when LED packages continue to operate under the conditions at $T_a = 25 \pm 2 \text{ }^\circ\text{C}$ and $I = (65)\text{mA}$ (per chip) until the brightness becomes $\leq 50\%$ of its original value.

Note (4) The module must be operated with constant driving current

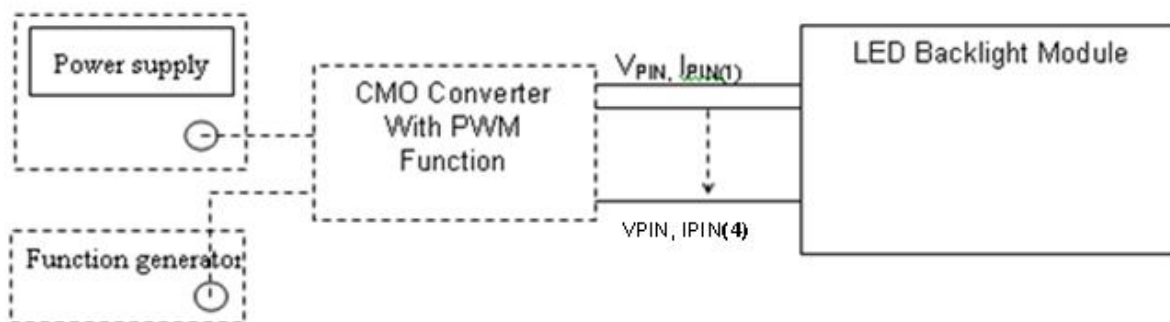

4.3.4 LIGHTBAR CONNECTOR PIN ASSIGNMENT

(1).Connector: WM13-406-063N & CI1406M1HRK-NH.

(2) LB Connector drawing:

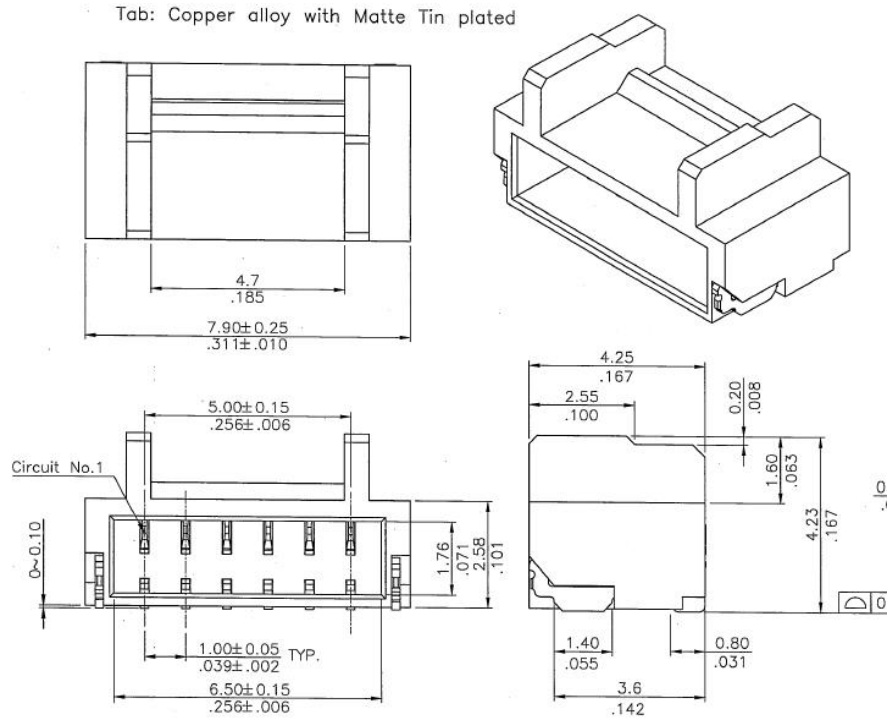

CN1

Pin number	Description
1	Cathode of LED string
2	Cathode of LED string
3	VLED
4	VLED
5	Cathode of LED string
6	Cathode of LED string

Note (1) User's Mating Connector Part No.: CI1406SL000-NH (CviLux) or Compatible.

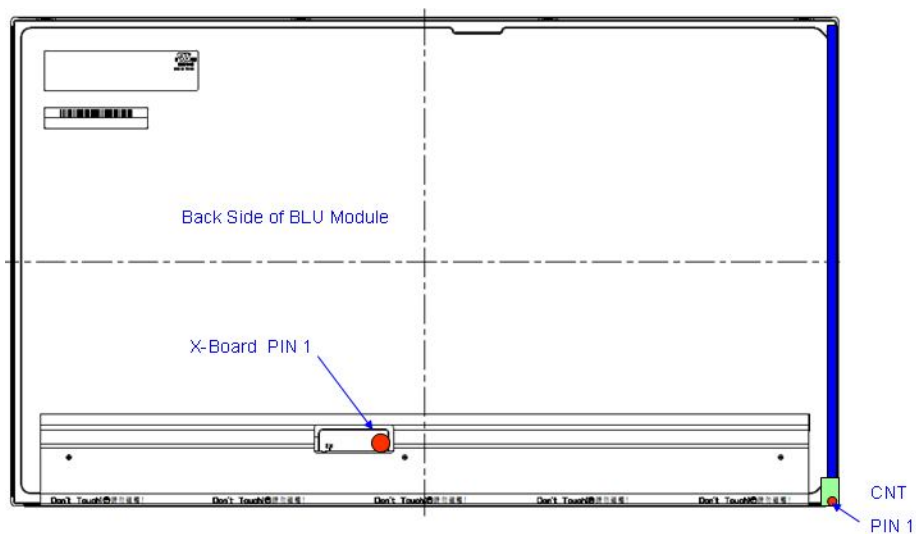

4.4 LVDS INPUT SIGNAL SPECIFICATIONS

4.4.1 LVDS DATA MAPPING TABLE

LVDS Channel O0	LVDS output	D7	D6	D4	D3	D2	D1	D0
	Data order	OG0	OR5	OR4	OR3	OR2	OR1	OR0
LVDS Channel O1	LVDS output	D18	D15	D14	D13	D12	D9	D8
	Data order	OB1	OB0	OG5	OG4	OG3	OG2	OG1
LVDS Channel O2	LVDS output	D26	D25	D24	D22	D21	D20	D19
	Data order	DE	NA	NA	OB5	OB4	OB3	OB2
LVDS Channel O3	LVDS output	D23	D17	D16	D11	D10	D5	D27
	Data order	NA	OB7	OB6	OG7	OG6	OR7	OR6
LVDS Channel E0	LVDS output	D7	D6	D4	D3	D2	D1	D0
	Data order	EG0	ER5	ER4	ER3	ER2	ER1	ER0
LVDS Channel E1	LVDS output	D18	D15	D14	D13	D12	D9	D8
	Data order	EB1	EB0	EG5	EG4	EG3	EG2	EG1
LVDS Channel E2	LVDS output	D26	D25	D24	D22	D21	D20	D19
	Data order	DE	NA	NA	EB5	EB4	EB3	EB2
LVDS Channel E3	LVDS output	D23	D17	D16	D11	D10	D5	D27
	Data order	NA	EB7	EB6	EG7	EG6	ER7	ER6

4.5 DISPLAY TIMING SPECIFICATIONS

The input signal timing specifications are shown as the following table and timing diagram.

Signal	Item	Symbol	Min.	Typ.	Max.	Unit	Note
LVDS Clock	Frequency	Fc	56	74.25	97.98	MHz	
	Period	Tc	-	13.47		ns	
	Input cycle to cycle jitter	T _{rcl}	-0.02*TC	-	0.02*TC	ns	(1)
	Input Clock to data skew	TLVCCS	-0.02*TC		0.02*TC		(2)
	Spread spectrum modulation range	F _{ckin_mod}	0.97*FC	-	1.03*FC	MHz	(3)
	Spread spectrum modulation frequency	F _{SSM}	-	-	100	KHz	
Vertical Display Term	Frame Rate	Fr	50	60	75	Hz	
	Total	Tv	1105	1125	1251	Th	Tv=Tvd+Tvb (5)-
	Active Display	Tvd	1080	1080	1080	Th	-
	Blank	Tvb	Tv-Tvd	Tv-Tvd	Tv-Tvd	Th	-
Horizontal Display Term	Total	Th	1050	1100	1150	Tc	Th=Thd+Thb
	Active Display	Thd	960	960	960	Tc	-
	Blank	Thb	Th-Thd	Th-Thd	Th-Thd	Tc	-

Note: Because this module is operated by DE only mode, Hsync and Vsync input signals are ignored.

$$F_c = F_r \times T_v \times T_h$$

Please make sure the range of pixel clock has follow the below equation and Fc, Fr, Tv, Th not allowed to get beyond the min or max spec.

INPUT SIGNAL TIMING DIAGRAM

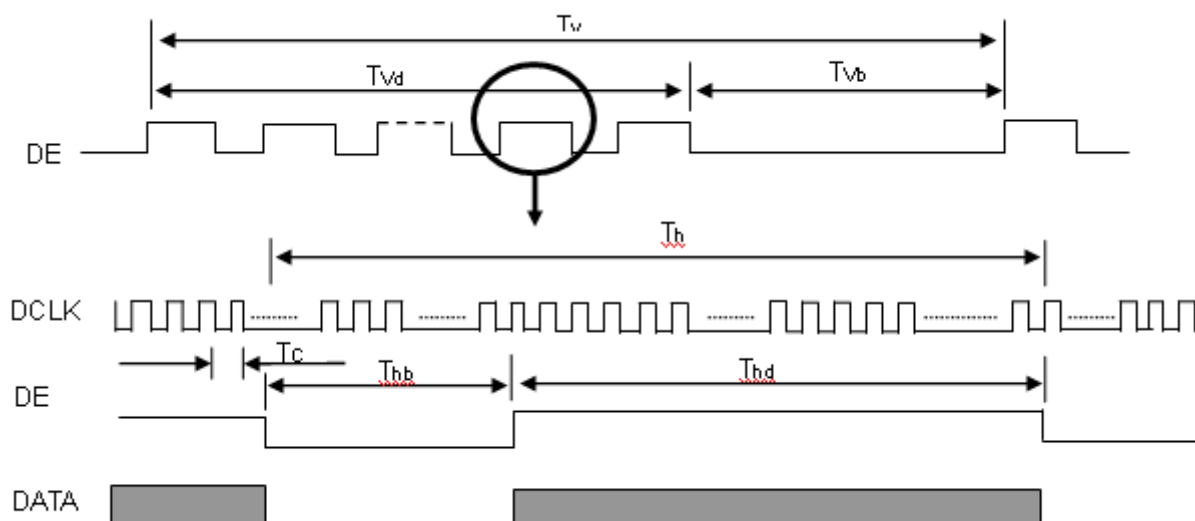

Note (1) The input clock cycle-to-cycle jitter is defined as below figures. $Trcl = |T_1 - T_1'|$

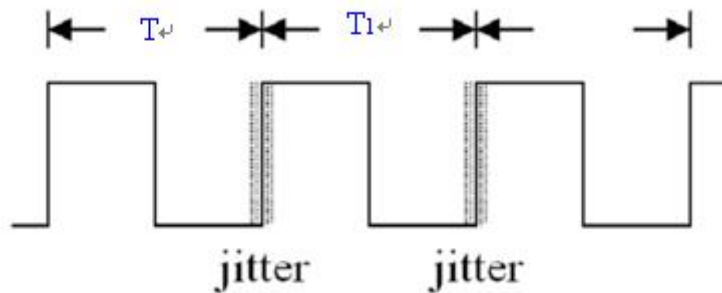

Note (2) Input Clock to data skew is defined as below figures.

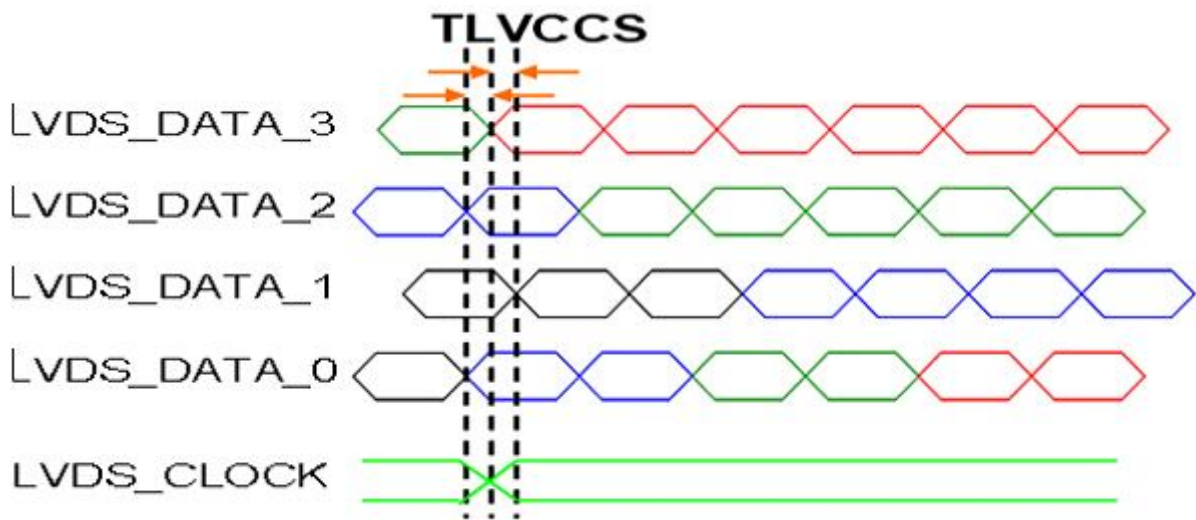

Note (3) The SSCG (Spread spectrum clock generator) is defined as below figures.

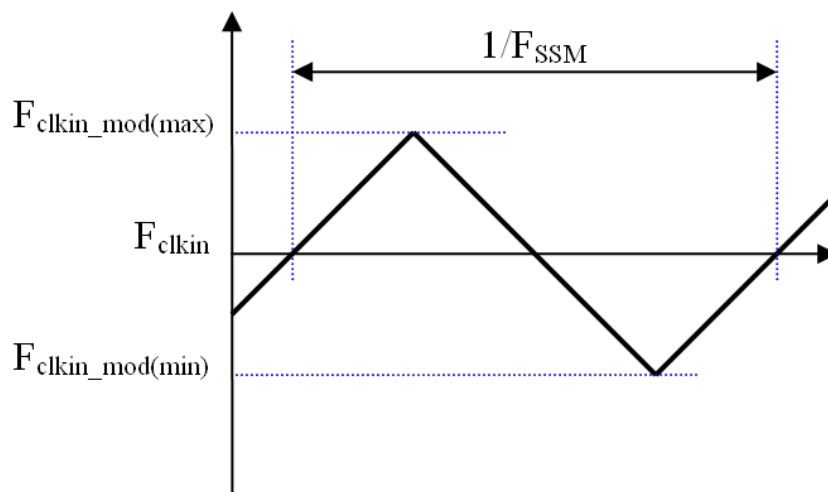

Note (4) The DCLK range at last line of V-blank should be set in 0 to $H_{display}/2$

Note (5) Please make sure the range of pixel clock has follow the below equation:

$$Fc(\max) \geq Fr \times Tv \times Th$$

$$Fr \times Tv \times Th \geq Fc(\min)$$

Note (6) In Free-sync mode, only guaranteed no functional failure, but don't guaranteed its quality of the optical and cosmetic performance.

4.6 POWER ON/OFF SEQUENCE

The power sequence specifications are shown as the following table and diagram.

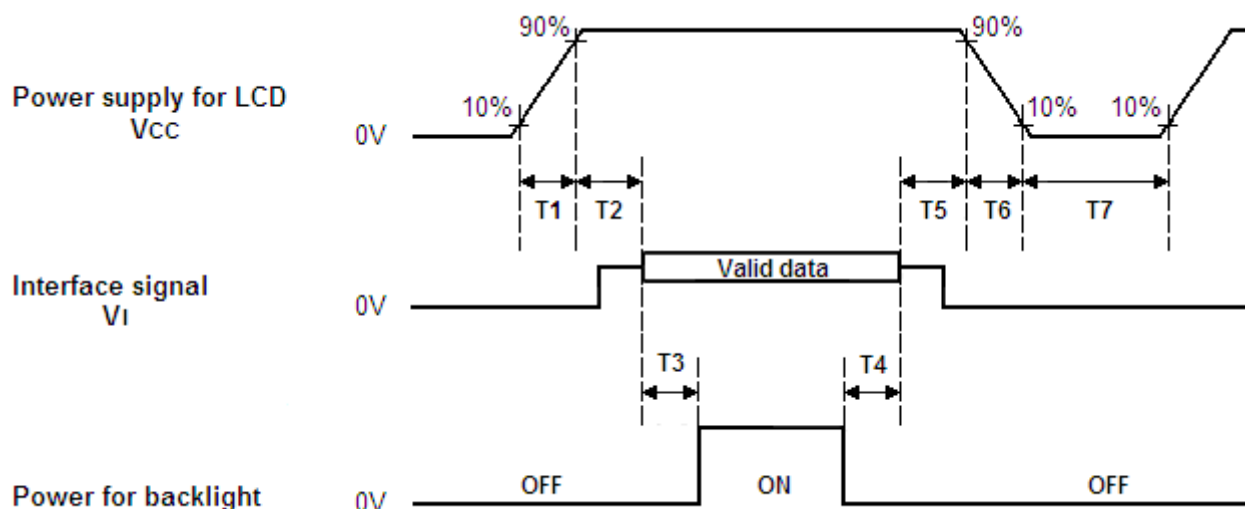

Timing Specifications:

Parameters	Values			Units
	Min	Typ.	Max	
T1	0.5	--	10	ms
T2	0	30	50	ms
T3	450	--	--	ms
T4	100	250	--	ms
T5	0	20	50	ms
T6	0.1	--	100	ms
T7	1000	--	--	ms

Note (1) The supply voltage of the external system for the module input should be the same as the definition of Vcc.

Note (2) When the backlight turns on before the LCD operation of the LCD turns off, the display may momentarily become abnormal screen.

Note (3) In case of VCC = off level, please keep the level of input signals on the low or keep a high impedance.

Note (4) T7 should be measured after the module has been fully discharged between power off and on period.

Note (5) Interface signal shall not be kept at high impedance when the power is on.

Note (6) INX won't take any responsibility for the products which are damaged by the customers not following the Power Sequence.

Note (7) There might be slight electronic noise when LCD is turned off (even backlight unit is also off). To avoid this symptom, we suggest "Vcc falling timing" to follow "t6 spec".

5. OPTICAL CHARACTERISTICS

5.1 TEST CONDITIONS

Item	Symbol	Value	Unit
Ambient Temperature	Ta	25±2	oC
Ambient Humidity	Ha	50±10	%RH
Supply Voltage	VCC	5	V
Input Signal	According to typical value in "3. ELECTRICAL CHARACTERISTICS"		
LED Light Bar Input Current Per Input Pin	IPIN	65 ± 1.5	mADC
PWM Duty Ratio	D	100	%
LED Light Bar Test Converter	(INX Part No.: R373B0000UT000)		

5.2 OPTICAL SPECIFICATIONS

The relative measurement methods of optical characteristics are shown in 5.2. The following items should be measured under the test conditions described in 5.1 and stable environment shown in Note (5).

Item	Symbol	Condition	Min.	Typ.	Max.	Unit	Note					
Color Chromaticity (CIE 1931)	Red	Rx	Typ – 0.03	0.644	Typ + - 0.03	-	(1), (5)					
		Ry		0.337								
	Green	Gx		0.317								
		Gy		0.617								
	Blue	Bx		0.152								
		By		0.054								
	White	Wx		0.313								
		Wy		0.329								
	Center Luminance of White (Center of Screen)	Lc		$\theta_x=0^\circ, \theta_y=0^\circ$ CS-2000 R=G=B=255 Gray scale				200	250	-	cd/m ²	(4), (5)
	Contrast Ratio	CR						2000	3000	-	-	(2), (5)
Response Time	T _R			20	25	ms	(3)					
	T _F			5	10	ms	(3)					
White Variation	δW	$\theta_x=0^\circ, \theta_y=0^\circ$	70	-	-	%	(5), (6)					
Viewing Angle	Horizontal	$\theta_{x-} + \theta_{x+}$	CR ≥ 10	160	178	-	Deg.	(1), (5)				
	Vertical	$\theta_{y-} + \theta_{y+}$		160	178	-						

Note (1) Definition of Viewing Angle (θ_x, θ_y):

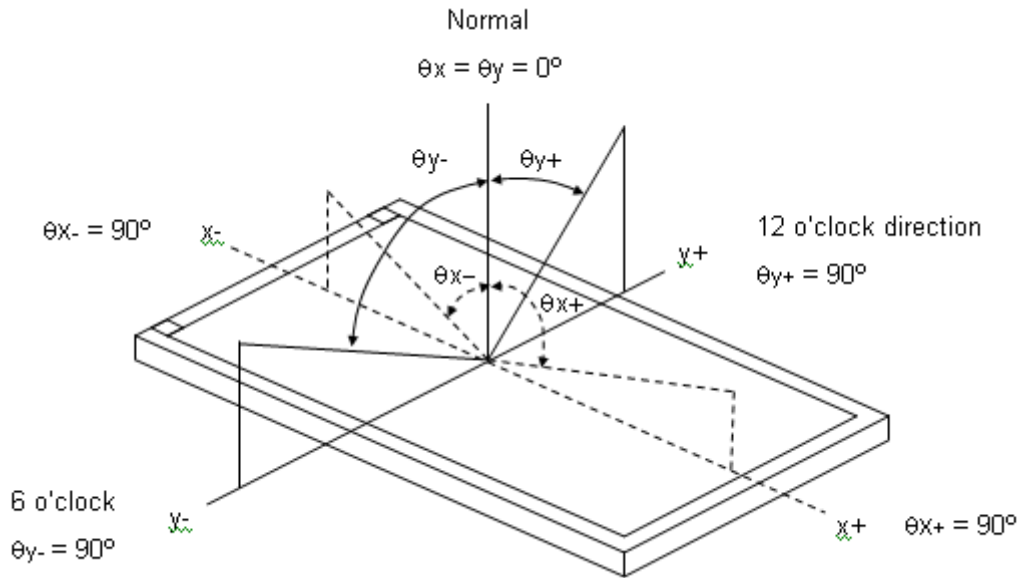

Note (2) Definition of Contrast Ratio (CR):

The contrast ratio can be calculated by the following expression.

$$\text{Contrast Ratio (CR)} = L_{255} / L_0$$

L255: Luminance of gray level 255

L 0: Luminance of gray level 0

$$\text{CR} = \text{CR} (5)$$

CR (X) is corresponding to the Contrast Ratio of the point X at Figure in Note (6).

Note (3) Definition of Response Time :

-The TR is the rising-time means the transition time from “Full-Black (gray 0)” to “Full-White (gray 255)” and the TF is the falling-time means the transition time from “Full-White (gray 255)” to “Full-White (gray 0)” as the following figure.(Measured by TEKTRONIX TDS3054B).

Note (4) Definition of Luminance of White (L_c):

Measure the luminance of gray level 255 at center point

$$L_c = L (5)$$

L (x) is corresponding to the luminance of the point X at Figure in Note (6).

Note (5) Measurement Setup:

The LCD module should be stabilized at given temperature for 40 minutes to avoid abrupt temperature change during measuring. In order to stabilize the luminance, the measurement should be executed after lighting Backlight for 40 minutes in a windless room.

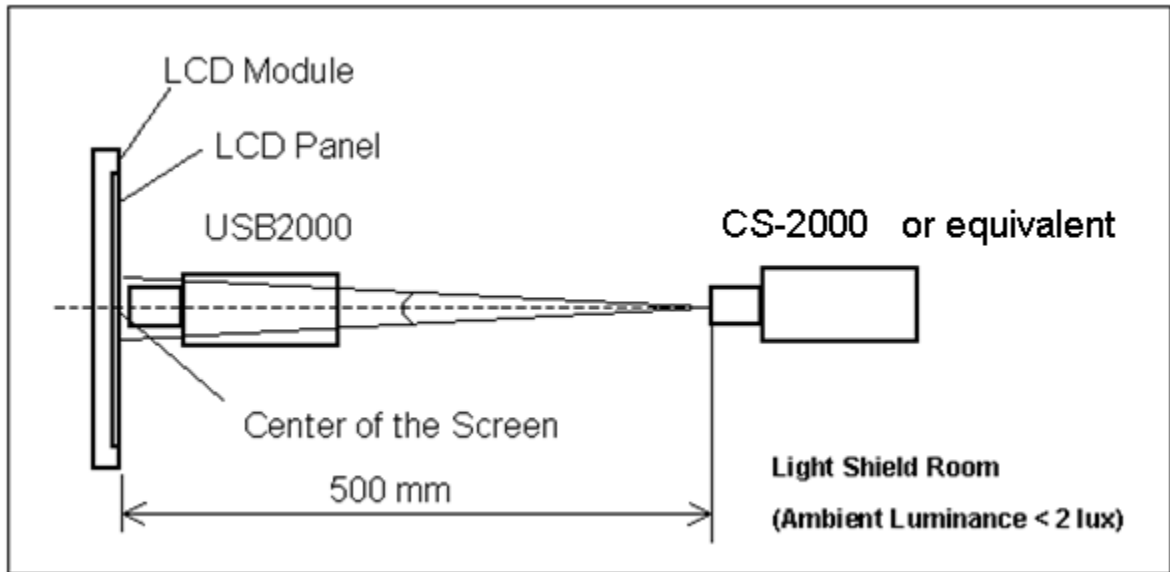

Note (6) Definition of White Variation (δW):

Measure the luminance of gray level 255 at 9 points

$$\delta W = (\text{Minimum } [L(1) \sim L(9)] / \text{Maximum } [L(1) \sim L(9)]) * 100\%$$

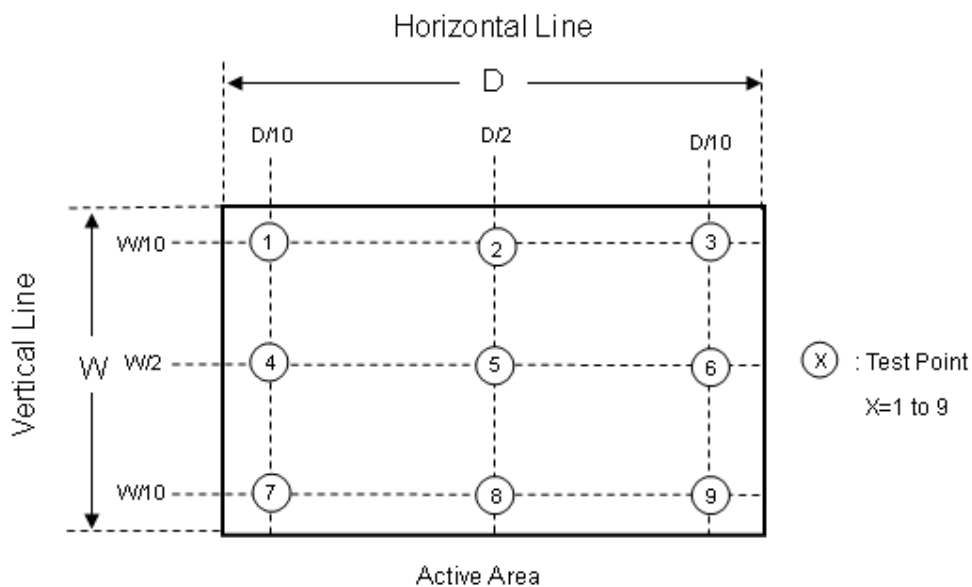

6. RELIABILITY TEST ITEM

Items	Required Condition	Note
Temperature Humidity Bias (THB)	Ta= 50°C , 80%RH, 240hours	-
High Temperature Operation (HTO)	Ta= 50°C , 240hours	-
Low Temperature Operation (LTO)	Ta= 0°C , 240hours	-
High Temperature Storage (HTS)	Ta= 60°C , 240hours	-
Low Temperature Storage (LTS)	Ta= -20°C , 240hours	-
Vibration Test (Non-operation)	Acceleration: 1.5 G Wave:sine Frequency: 10 - 300 Hz Sweep: 30 Minutes each Axis (X, Y, Z)	-
Shock Test (Non-operation)	Acceleration: 50 G Wave: Half-sine Active Time: 11 ms Direction : ± X, ± Y, ± Z.(one time for each Axis)	-
Thermal Shock Test (TST)	-20°C/30min , 60°C / 30min , 100 cycles	-
On/Off Test	25°C ,On/10sec , Off /10sec , 30,000 cycles	-
ESD (Electro Static Discharge)	Contact Discharge: ± 8KV, 150pF(330Ω)	-
	Air Discharge: ± 15KV, 150pF(330Ω)	-
Altitude Test	Operation:10,000 ft / 24hours	-
	Non-Operation:30,000 ft / 24hours	-

Note (1) criteria : Normal display image with no obvious non-uniformity and no line defect.

Note (2) Evaluation should be tested after storage at room temperature for more than two hours.

Note (3) At testing Vibration and Shock, the fixture in holding the module has to be hard and rigid enough so that the module would not be twisted or bent by the fixture.

The fixing condition is shown as below:

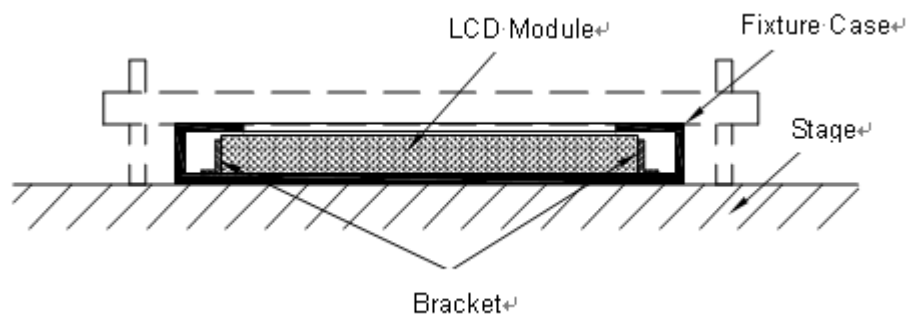

7. MECHANICAL STRENGTH CHARACTERISTICS

7.1 MECHANICAL STRENGTH SPECIFICATIONS

Item	Condition	Min	Unit	Note
Mechanical Strength	128 th Gray Pattern	0.6	Kgf	

7.2 TEST CONDITIONS

Items	Description
Test Condition	1. Ambient Illumination : 10~15 lux 2. Test Pattern : 128 Gray 3. Distance of the judgment : 30cm from the surface of module 4. Viewing angle of the judgment : Front
Gage Information	1. Push pull guage a. Model name : HF-50, maker : ALGOL b. Shape of gage tip - Diameter : 2mm - Thickness : 2mm
Definition of Minimum force	To measure minimum force when operator detects any white spot and light leakage that have occurred while operator presses on back side of module with push pull gage.

7.3 DEFINITION OF TEST POINTS

Measure the minimum force of test points at 128th Gray pattern. The test points at back side of module area is showing as below . (If the test points on the PCBA or TP board, these points are not included).

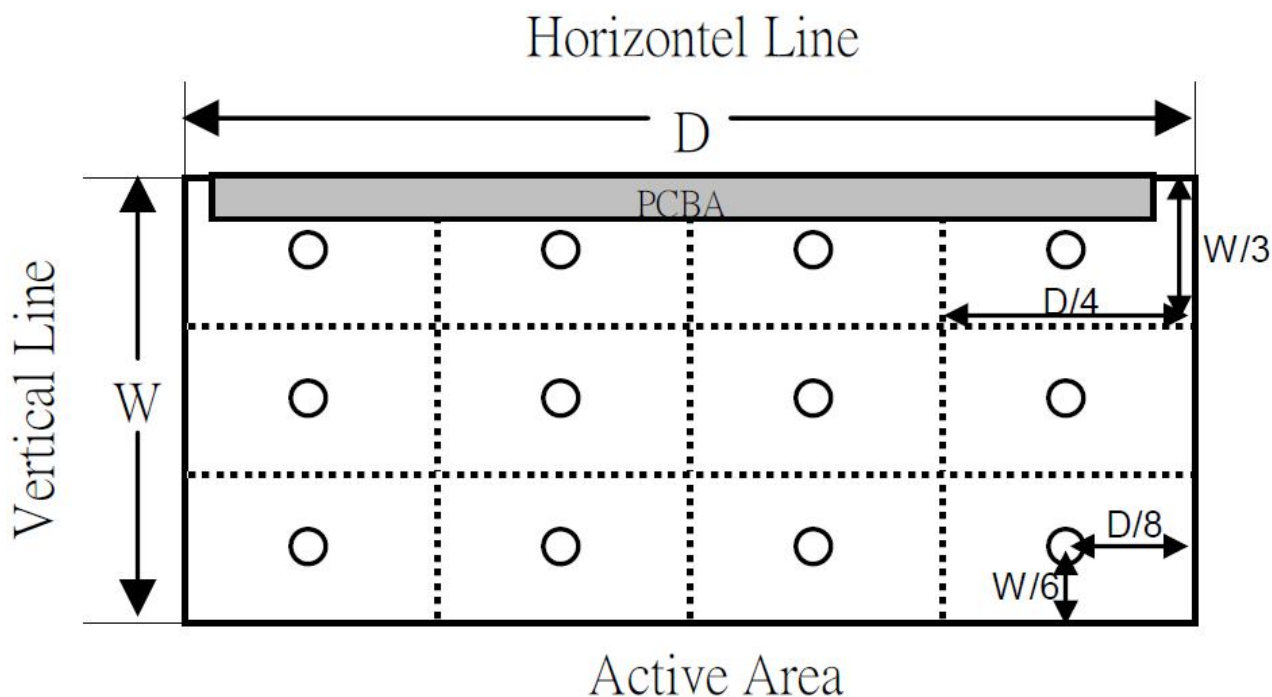

8. PACKING

8.1 PACKING SPECIFICATIONS

- (1) 10 LCD modules / 1 Box
- (2) Box dimensions: 567(L) X 301(W) X 376(H) mm
- (3) Weight: approximately: 20.5kg (10 modules per box)

8.2 PACKING METHOD

Box Dimensions : 567(L)*301(W)*376(H)mm
10 module per. 1 box

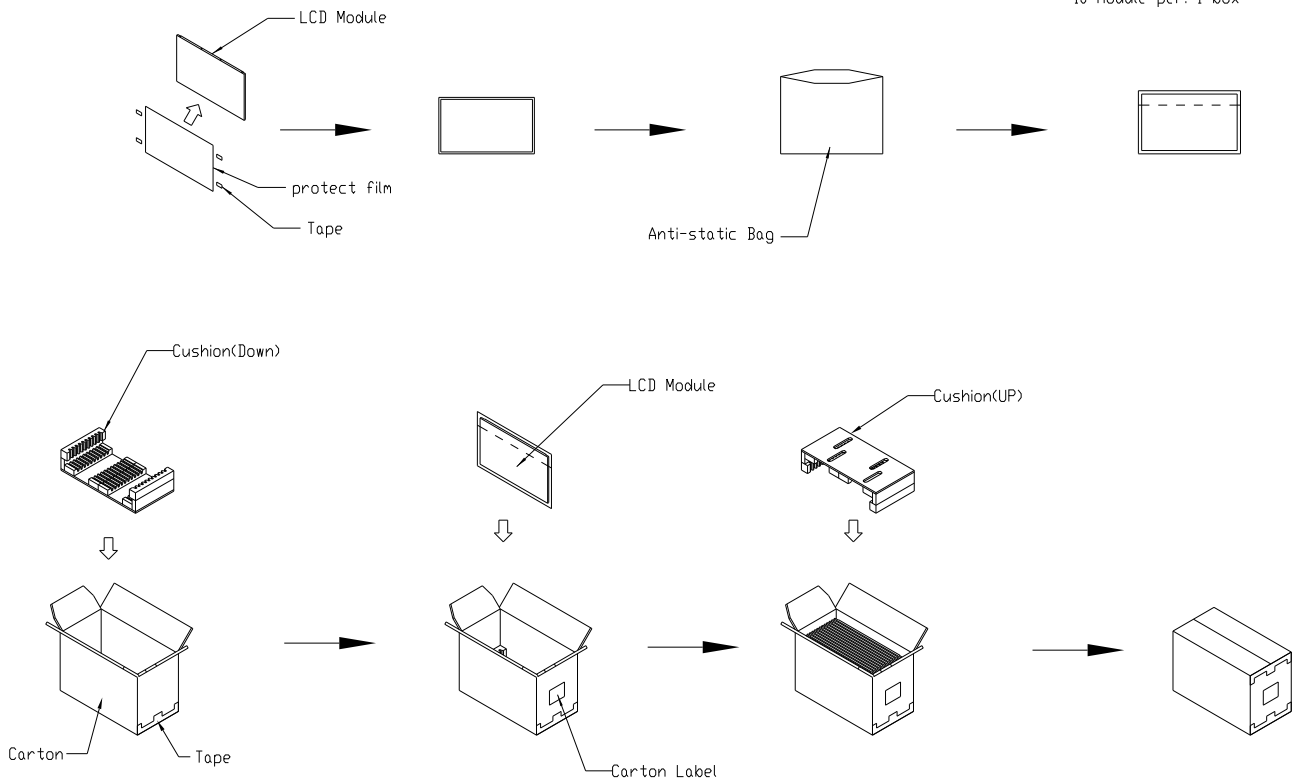

Figure. 8-1 Packing method

8.3 PALLET

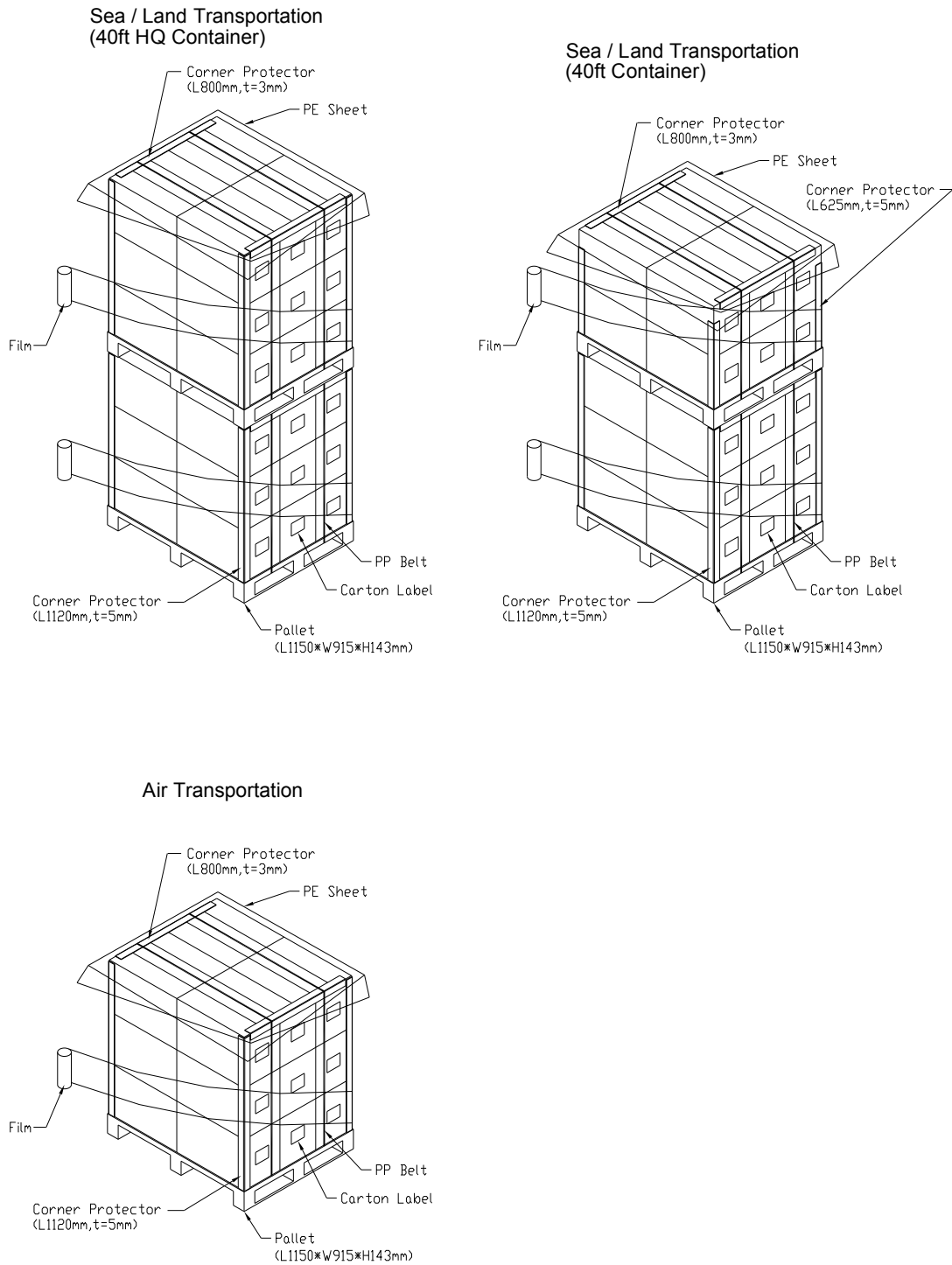

Figure. 8-2 Packing method

8.4 UN-PACKING METHOD

UN-packaging method is shown as following figures.

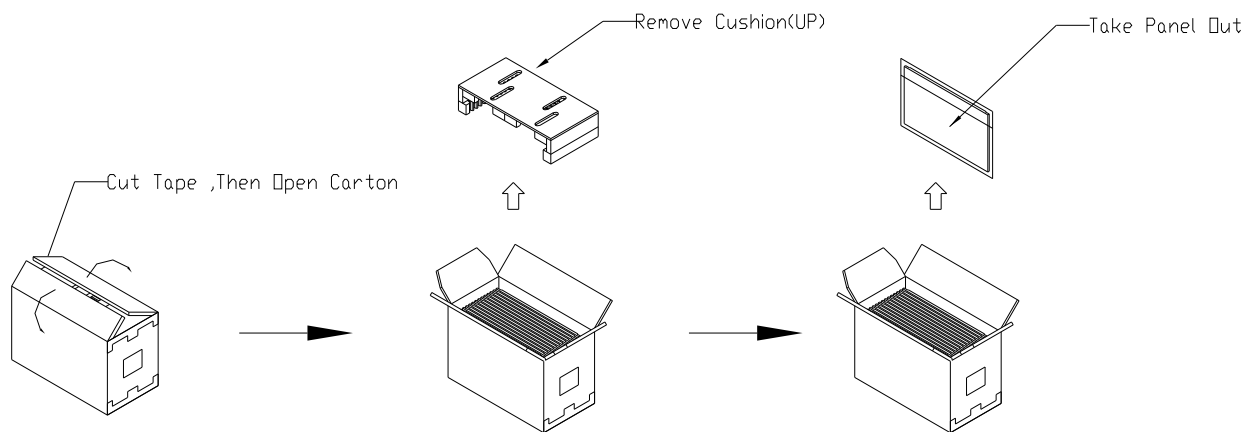

Figure. 8-3 Un-packing method

9. INX MODULE LABEL

The barcode nameplate is pasted on each module as illustration, and its definitions are as following explanation.



(a) Model Name: M215HJJ-L30

(b) Revision: Rev. XX, for example: A0, A1... B1, B2... or C1, C2...etc.

(c) INX barcode definition:

Serial ID: XX-XX-X-XX-YMD-L-NNNN

Code	Meaning	Description
XX	INX internal use	-
XX	Revision	Cover all the change
X	INX internal use	-
XX	INX internal use	-
YMD	Year, month, day	Year: 0~9, 2001=1, 2002=2, 2003=3...2010=0, 2011=1, 2012=2... Month: 1~12=1, 2, 3, ~, 9, A, B, C Day: 1~31=1, 2, 3, ~, 9, A, B, C, ~, W, X, Y, exclude I, O, and U.
L	Product line #	Line 1=1, Line 2=2, Line 3=3, ...
NNNN	Serial number	Manufacturing sequence of product

(d) Customer's barcode definition:

Serial ID: CM- L5J30-X-X-X-XX-L-XX-L-YMD-NNNN

Code	Meaning	Description
CM	Supplier code	INX=CM
L5J30	Model number	M215HJJ-L30= L5J30
X	Revision code	Non ZBD: 1,2,~,8,9 / ZBD: A~Z
X	Source driver IC code	Century=1, CLL=2, Demos=3, Epson=4, Fujitsu=5, Himax=6, Hitachi=7, Hynix=8, LDI=9, Matsushita=A, NEC=B, Novatek=C, OKI=D, Philips=E, Renesas=F, Samsung=G, Sanyo=H, Sharp=I, TI=J, Topro=K, Toshiba=L, Windbond=M, ILITEK=Q, Fiti=Y, None IC =Z
X	Gate driver IC code	
XX	Cell location	Tainan Taiwan=TN, Ningbo China=CN, Hsinchu Taiwan=SC
L	Cell line #	1,2,~,9,A,B,~,Y,Z
XX	Module location	Tainan, Taiwan=TN ; Ningbo China=NP, Shenzhen China=SH Nanhai China=NH
L	Module line #	1,2,~,9,A,B,~,Y,Z
YMD	Year, month, day	Year: 0~9, 2001=1, 2002=2, 2003=3...2010=0, 2011=1, 2012=2... Month: 1~12=1, 2, 3, ~, 9, A, B, C Day: 1~31=1, 2, 3, ~, 9, A, B, C, ~, T, U, V
NNNN	Serial number	By LCD supplier

(e) FAB ID(UL Factory ID):

Region	Factory ID
TWINX	GEMN
NBINX	LEOO
NBINX	VIRO
NHINX	CAPG

10. PRECAUTIONS

10.1 ASSEMBLY AND HANDLING PRECAUTIONS

- (1) Do not apply rough force such as bending or twisting to the module during assembly.
- (2) To assemble or install module into user's system can be only in clean working areas. The dust and oil may cause electrical short or worsen the polarizer.
- (3) It's not permitted to have pressure or impulse on the module because the LCD panel and Backlight will be damaged.
- (4) Always follow the correct power sequence when LCD module is connecting and operating. This can prevent damage to the CMOS LSI chips during latch-up.
- (5) Do not pull the I/F connector in or out while the module is operating.
- (6) Do not disassemble the module.
- (7) Use a soft dry cloth without chemicals for cleaning, because the surface of polarizer is very soft and easily scratched.
- (8) It is dangerous that moisture come into or contacted the LCD module, because moisture may damage LCD module when it is operating.
- (9) High temperature or humidity may reduce the performance of module. Please store LCD module within the specified storage conditions.
- (10) When ambient temperature is lower than 10°C may reduce the display quality. For example, the response time will become slowly.
- (11) While touching the panel surface under the patterns with higher grey levels, a shadow or mura phenomenon would be seen. This phenomenon is totally recoverable by switching the patterns to lower grey levels. It is a product feature

10.2 STORAGE PRECAUTIONS

- (1) Do not leave the module in high temperature, and high humidity for a long time. It is highly recommended to store the module with temperature from 0°C to 35°C and relative humidity of less than 90%
- (2) Do not store the TFT – LCD module in direct sunlight
- (3) The module should be stored in dark place. It is prohibited to apply sunlight or fluorescent light in storing

10.3 OPERATION PRECAUTIONS

(1) The LCD product should be operated under normal condition.

Normal condition is defined as below :

Temperature : $20\pm 15^{\circ}\text{C}$

Humidity: $65\pm 20\%$

Display pattern : continually changing pattern(Not stationary)

(2) If the product will be used in extreme conditions such as high temperature,high humidity,high altitude ,display pattern or operation time etc...It is strongly recommended to contact CMI for application engineering advice . Otherwise , Its reliability and function may not be guaranteed..

10.4 SAFETY PRECAUTIONS

(1) If the liquid crystal material leaks from the panel, it should be kept away from the eyes or mouth. In case of contact with hands, skin or clothes, it has to be washed away thoroughly with soap.

(2) After the module's end of life, it is not harmful in case of normal operation and storage.

10.5 SAFETY STANDARDS

The LCD module should be certified with safety regulations as follows:





(1) UL60950-1 or updated standard.

(2) IEC60950-1 or updated standard.

10.6 OTHER

When fixed patterns are displayed for a long time, remnant image is likely to occur.

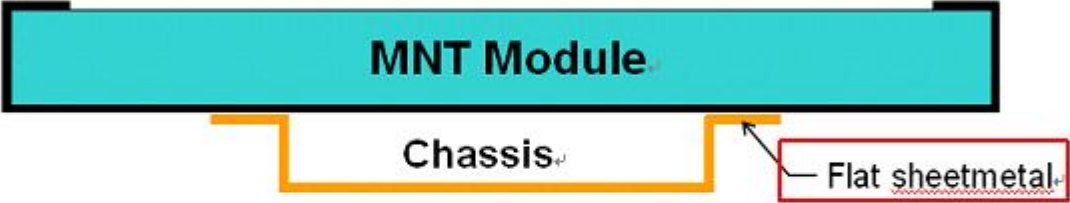
Appendix 1. SYSTEM COVER DESIGN NOTICE

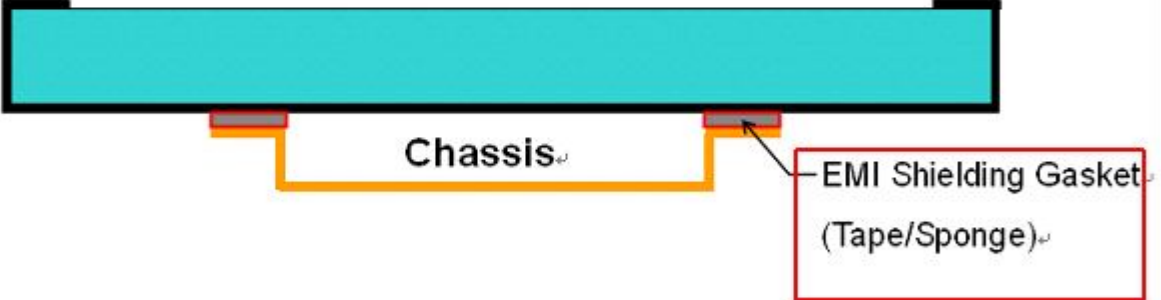
1.	Set Chassis and MNT Module touching Mode
	 <p style="text-align: center;">MNT Module</p> <p style="text-align: center;">Chassis</p> <p style="text-align: right;">spring</p>
	 <p style="text-align: center;">MNT Module</p> <p style="text-align: center;">Chassis</p> <p style="text-align: right;">Flat sheetmetal</p>
	 <p style="text-align: center;">MNT Module</p> <p style="text-align: center;">Chassis</p> <p style="text-align: right;">EMI Shielding Gasket (Tape/Sponge)</p>
<p>Definition</p>	<p>a) To prevent from abnormal display & white spot after Mechanical test, it is not recommended to used spring type chassis.</p> <p>b) We suggest the contact mode between Chassis and Module rear cover is Tape/Sponge, second is Flat sheetmetal type chassis (Don't interference from flat sheetmetal of chassis to rear cover of Module).</p>

2	Tape/sponge design on system inner surface
Definition	<p>a) To prevent from abnormal display & white spot after Mechanical test, We suggest using Tape/Sponge as medium between chassis and Module rear cover could reduce the occurrence of white spot.</p> <p>b) When using the Tape/Sponge, suggest it be lay over between set chassis and module rear cover. it is not recommended to add tape/sponge in separate location. Since each tape/sponge may act as pressure concentration location.</p>

3	System inner surface examination
<p>The diagram illustrates the system inner surface examination. It shows a light blue rectangular area representing the system cover. Below this, a black hatched area represents the MNT Module. Below the module, a cross-section of the system cover inner surface is shown, featuring a light blue chassis with a green PCB board. Labels indicate 'Burr' at the edges, 'Chassis', 'PCB', and 'Step'. The 'System cover inner surface' is labeled at the bottom. A red hatched area on the PCB board is highlighted, indicating a specific area of interest.</p>	
Definition	<p>a). Burr at logo edge, step, protrusion or PCB board will easily cause white spot.</p> <p>b). Keeping flat surface underneath module is recommended.</p> <p>c). The area () on Module PCBA and Light bar connector should keep at least .1mm gap to any structure with System cover inner surface.</p>

4	The overlapping part on System's Chassis and electric wire needs gap structure.
<p>The diagram illustrates the required gap structure for FFC and wire connections on a chassis. It consists of three parts: two cross-sectional views and a top-down view. The top-left cross-section, labeled 'A-A Section', shows an 'FFC electric wire' (red) and a 'Module' (grey) on a 'Chassis' (orange). The bottom-left cross-section, labeled 'B-B Section', shows an 'electric wire' (black, red, and blue) and a 'Module' on a 'Chassis'. The top-right view shows the 'Chassis' with an 'FFC' connector and a 'Wire' connector. The 'LVDS Connector' is shown at the bottom, and the 'Light bar Connector' is shown on the right. Red jagged lines indicate the gap structure at the connection points between the chassis and the wires.</p>	
Definition	The overlapping part on System's Chassis and electric wire (FFC、FFC and wire) needs gap structure to avoid display of white spot by pressing overlapping part cause interference.

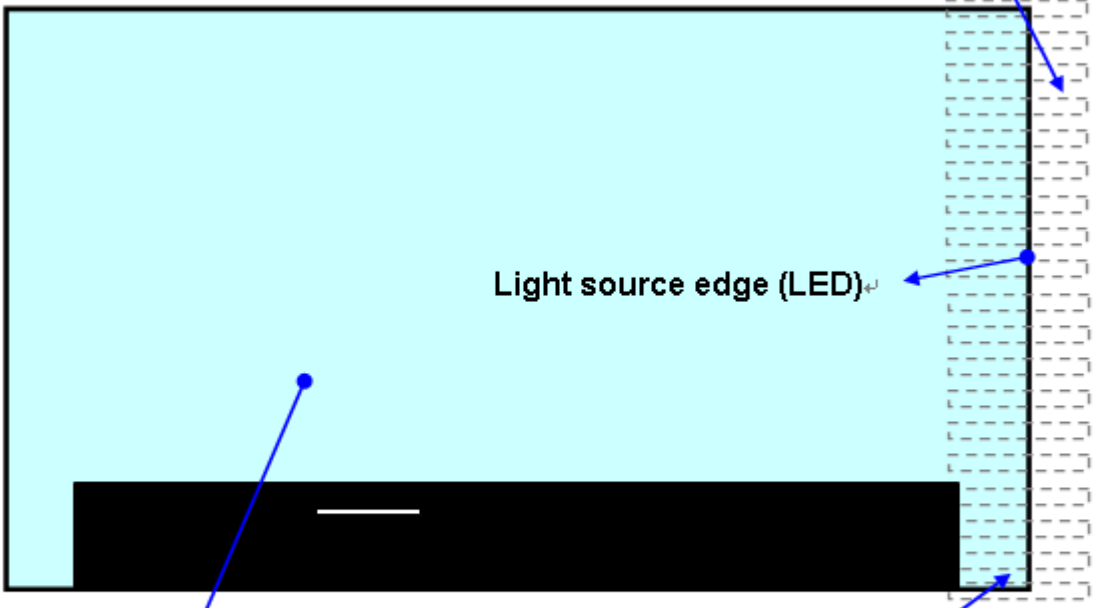
5	System cover's ventilation outlet structure
<p style="text-align: center;">Set ventilation outlet structure on Light source side of module</p>  <p style="text-align: center;">Light source edge (LED)</p> <p style="text-align: center;">Module Light source Connector</p>	
Definition	To prevent from abnormal display of light leakage, We suggest to set ventilation outlet structure on side of Module Light bar in system cover inner surface.

Appendix 2. OUTLINE DRAWING