

# Model Name: P270HVN03.0

Issue Date : 2022/06/08

**(\*) Preliminary Specifications**

**( ) Final Specifications**

Customer Signature	Date	AUO Display Plus	Date
<b>Approved By</b>  _____		<b>Approval by PM Director</b> <b>CT Wu</b>  _____	
<b>Note</b>		<b>Reviewed by RD Director</b> <b>Lamy Chen</b>  _____  <b>Reviewed by Project Leader</b> <b>Pei Yu Tsai</b>  _____  <b>Prepared by PM</b> <b>Christy Hsu</b>  _____	

Content

1 HANDLING PRECAUTIONS ..... 5

2 GENERAL DESCRIPTION ..... 6

2.1 Display Characteristics ..... 6

2.2 Absolute Ratings of Environment ..... 8

2.3 Optical Characteristics..... 9

2.4 Mechanical Characteristics..... 13

3 TFT-LCD Module..... 14

3.1 Block Diagram ..... 14

3.2 Interface Connection..... 15

3.2.1 Connector Type ..... 15

3.2.2 Connector Pin Assignment ..... 15

3.3 Electrical Characteristics ..... 17

3.3.1 Absolute Maximum Rating..... 17

3.3.2 Recommended Operating Condition ..... 17

3.4 Signal Characteristics ..... 18

3.4.1 LCD Pixel Format ..... 18

3.4.2 LVDS Data Format ..... 18

3.4.3 Color versus Input Data ..... 19

3.4.4 LVDS Specification ..... 19

3.4.5 Input Timing Specification..... 21

3.4.6 Input Timing Diagram ..... 22

3.5 Power ON/OFF Sequence..... 23

4 Backlight Unit..... 24

4.1 Block Diagram ..... 24

4.2 Interface Connection..... 25

4.2.1 Connector Type ..... 25

4.2.2 Connector Pin Assignment ..... 26

4.3 Electrical Characteristics ..... 26

4.3.1 Absolute Maximum Rating..... 26

4.3.2 Recommended Operating Condition ..... 27

5 Reliability Test ..... 28

6 Shipping Label..... 29

7 Mechanical Characteristics..... 31

8 Packing Specification ..... 34

8.1 Packing Flow ..... 34

8.2 Pallet and shipment information ..... 36

9 INTERNATIONAL STANDARD ..... 37

9.1 Safety ..... 37

9.2 EMC ..... 37

10 PRECAUTIONS..... 38

10.1 Mounting Precautions ..... 38

10.2 Operating Precautions ..... 38

10.3 Operating Condition for Public Information Display ..... 38

10.4 Electrostatic Discharge Control ..... 39

10.5 Precautions for Strong Light Exposure ..... 39

10.6 Storage ..... 39

10.7 Handling Precautions for Protection Film..... 39

10.8 Dust Resistance ..... 40

### Records of Revision

<b>Version</b>	<b>Date</b>	<b>Page</b>	<b>Old description</b>	<b>New Description</b>	<b>Remark</b>
0.0	2022/6/08	All		First Preliminary Specifications	

## 1 Handling Precautions

- 1) Since polarizer is easily damaged, do not touch or press the surface of polarizer with hand.
- 2) Be sure to turn off power supply when inserting or disconnecting from input connector.
- 3) Wipe off water drop immediately. Long contact with water may cause discoloration or spots.
- 4) When the panel surface is soiled, wipe it with absorbent cotton or other soft cloth.
- 5) Since the panel is made of glass, it may break or crack if dropped or bumped on hard surface.
- 6) Since CMOS LSI is used in this module, take care of static electricity and insure human earth when handling.
- 7) Do not open or modify the Module Assembly.
- 8) Do not press the reflector sheet at the back of the module to any directions.
- 9) In case a TFT-LCD Module has to be put back into the packing container slot after once it was taken out from the container, do not press the center of the LED lightbar edge. Otherwise the TFT-LCD Module may be damaged.
- 10) Insert or pull out the interface connector, be sure not to rotate nor tilt it of the TFT-LCD Module.
- 11) Do not twist nor bend the TFT -LCD Module even momentary. It should be taken into consideration that no bending/twisting forces are applied to the TFT-LCD Module from outside. Otherwise the TFT-LCD Module may be damaged.
- 12) Please avoid touching COF position while you are doing mechanical design.
- 13) When storing modules as spares for a long time, the following precaution is necessary: Store them in a dark place. Do not expose the module to sunlight or fluorescent light. Keep the temperature between 5°C and 35°C at normal humidity.
- 14) Do not apply the same pattern for a long time, it will enhance relevant defect.

## 2 General Description

This specification applies to the 27 inch-FHD color a-Si TFT-LCD Module P270HVN02.0 The display supports the FHD - 1920(H) x 1080(V) screen format and 16.7M colors (RGB 8-bit data input). The light source of this TFT-LCD module is W-LED. All input signals are 2-channel LVDS interface and this module doesn't contain a driver for backlight.

### 2.1 Display Characteristics

The following items are characteristics summary on the table under 25°C condition:

Items	Unit	Specification
Screen Diagonal	[mm]	685.65(27.0")
Active Area	[mm]	597.6 (H) x 336.15 (V)
Pixels H x V	-	1920(x3) x 1080
Pixel Pitch	[um]	311.25 (per one triad) x311.25
Pixel Arrangement	-	R.G.B. Vertical island
Display Mode	-	VA Mode, Normally Black
White Luminance ( Center )	[cd/m <sup>2</sup> ]	500 cd/m <sup>2</sup> (Typ.)
Contrast Ratio	-	3000 (Typ.)
Optical Response Time	[msec]	12ms (Typ., on/off)
Nominal Input Voltage VDD	[Volt]	5 V (Typ)
Power Consumption (LCD Module + Backlight unit)	[Watt]	26.14 watt LCD Module : PDD (typ), All white pattern at 60Hz = 4.65 W Backlight unit : PBLU (typ) = 21.49 W(@65mA)
Weight	[Grams]	3233
Outline Dimension	[mm]	623.7(H)x362.1(V)x12.0(D) Typ. (D) is refer to front bezel to LVDS CNT
Electrical Interface	-	Dual channel LVDS
Support Color	-	16.7M colors (RGB 6bit+Hi-FRC)
Surface Treatment	-	Anti-Glare 3H
Temperature Range		
Operating	[°C]	0 to +50
Storage (Shipping)	[°C]	-20 to +60
RoHS Compliance	-	RoHS Compliance
LED MTTF	[Hours]	Typ. 50000
Landscape / Portrait	-	Landscape / Portrait Enable (Note 1 / Note 2)
Frame Rate	[Hz]	60

**Note 1:** Rotate Function refers to LCD display could be able to rotate. This function does not work in this model.

**Note 2:**

- (1) Landscape Mode: The default placement is T-Con Side on the lower side and the image is shown upright via viewing from the front.
- (2) Portrait Mode: The default placement is that T-Con side has to be placed on the left side via viewing from the front.

**Landscape (Front view)**

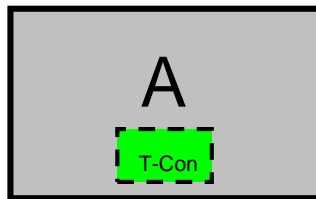

**Portrait (Front view)**

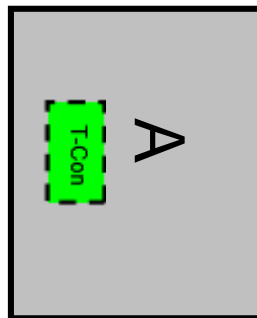

## 2.2 Absolute Ratings of Environment

Permanent damage may occur if exceeding the following maximum rating.

Symbol	Description	Min.	Max.	Unit	Remark
TOP	Operating Temperature	0	+50	[°C]	<b>Note 2-1</b>
TGS	Glass surface temperature (operation)	0	+65	[°C]	<b>Note 2-1</b> Function judged only
HOP	Operation Humidity	5	90	[%RH]	<b>Note 2-1</b>
TST	Storage Temperature	-20	+60	[°C]	
HST	Storage Humidity	5	90	[%RH]	

**Note 2-1:** Temperature and relative humidity range are shown as the below figure.

- 90% RH Max (  $T_a \leq 39^\circ\text{C}$  )
- Max wet-bulb temperature at  $39^\circ\text{C}$  or less. (  $T_a \leq 39^\circ\text{C}$  )
- No condensation

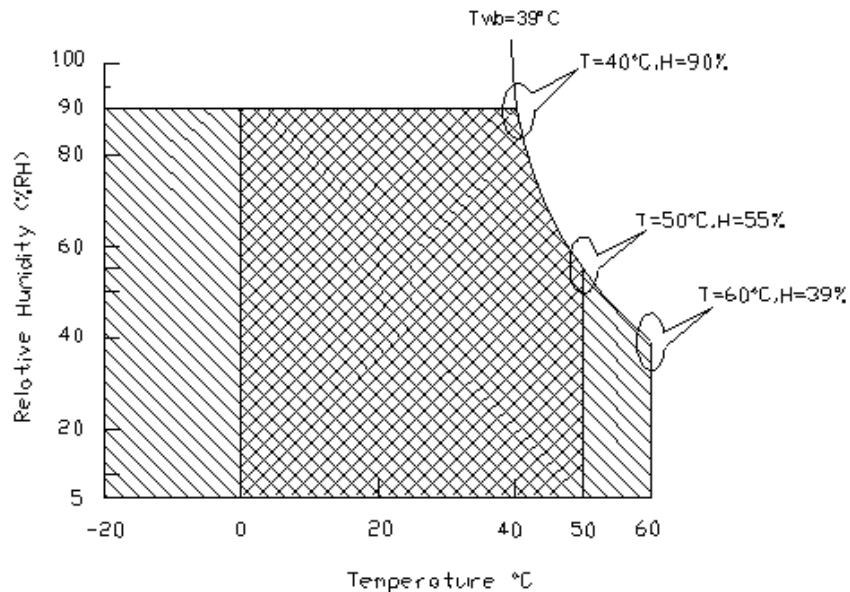

Operating Range  Storage Range  + 



### 2.3 Optical Characteristics

The optical characteristics are measured on the following test condition.

**Test Condition:**

1. Equipment setup: Please refer to **Note 2-2**.
2. Panel Lighting time: 30 minutes
3. VDD=5V, Fv=60Hz, Is=80mA, Ta=25°C

Symbol	Description		Min.	Typ.	Max.	Unit	Remark
L <sub>w</sub>	White Luminance (Center of screen)		400	500	-	[cd/m <sup>2</sup> ]	<b>Note 2-2</b> By SR-3
L <sub>uni</sub>	Luminance Uniformity (9 points)		75	80	-	[%]	<b>Note 2-3</b> By SR-3
CR	Contrast Ratio (Center of screen)		1800	3000	-	-	<b>Note 2-4</b> By SR-3
θ <sub>R</sub>	Horizontal Viewing Angle (CR=10)	Right	85	89	-	[degree]	<b>Note 2-5</b> By SR-3
θ <sub>L</sub>		Left	85	89	-		
Φ <sub>H</sub>	Vertical Viewing Angle (CR=10)	Up	85	89	-		
Φ <sub>L</sub>		Down	85	89	-		
T <sub>rR</sub>	Response Time	Raising Time	-	7	17	[msec]	<b>Note 2-6</b> By TRD-100
T <sub>rF</sub>		Falling Time		5	7		
T <sub>rR</sub> + T <sub>rF</sub>		Raising + Falling		12	24		
R <sub>x</sub>	Color Coordinates (CIE 1931)	Red x	Typ.+0.03	0.634(TBD)	Typ.+0.03	-	By SR-3
R <sub>y</sub>		Red y		0.333(TBD)			
G <sub>x</sub>		Green x		0.324(TBD)			
G <sub>y</sub>		Green y		0.601(TBD)			
B <sub>x</sub>		Blue x		0.153(TBD)			
B <sub>y</sub>		Blue y		0.054(TBD)			
W <sub>x</sub>		White x		0.313(TBD)			
W <sub>y</sub>		White y		0.329(TBD)			
CT	Crosstalk		-	-	1.5	[%]	<b>Note 2-7</b> By SR-3
NTSC				72		[%]	By SR-3
F <sub>dB</sub>	Flicker (Center of screen)		-	-	-20	[dB]	<b>Note 2-8</b> By SR-3

**Note 2-2:** Equipment setup :

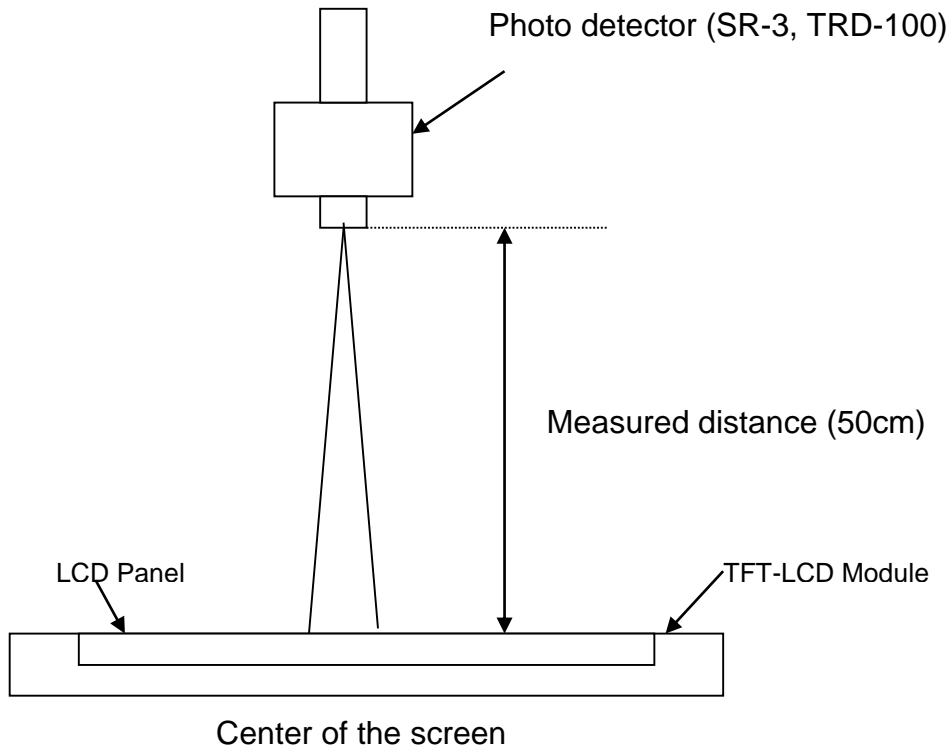

**Note 2-3:** Luminance Uniformity Measurement

**Definition:**

$$\text{Luminance Uniformity} = \frac{\text{Minimum Luminance of 9 Points (P1 ~ P9)}}{\text{Maximum Luminance of 9 Points (P1 ~ P9)}}$$

*a. Test pattern: White Pattern*

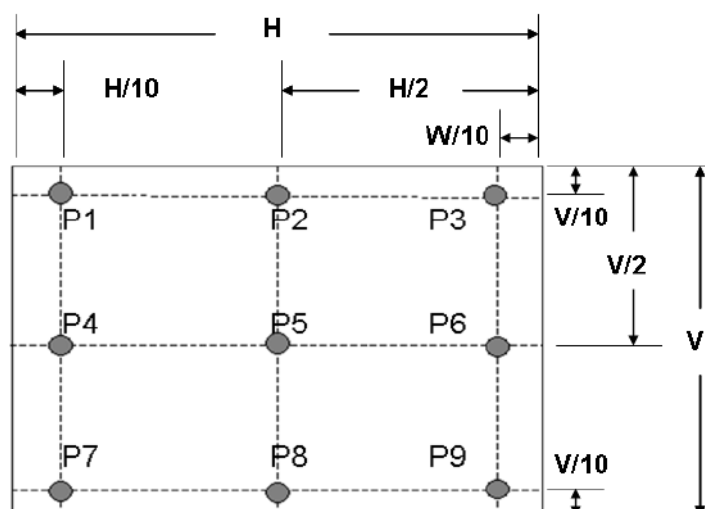

**Note 2-4: Contrast Ratio Measurement**

**Definition:**

$$\text{Contrast Ratio} = \frac{\text{Luminance of White pattern}}{\text{Luminance of Black pattern}}$$

- a. Measured position: Center of screen (P5) & perpendicular to the screen ( $\theta = \Phi = 0^\circ$ )

**Note 2-5: Viewing angle measurement**

**Definition:** The angle at which the contrast ratio is greater than 10.

- a. Horizontal view angle: Divide to left & right ( $\theta_L$  &  $\theta_R$ )  
Vertical view angle: Divide to up & down ( $\Phi_H$  &  $\Phi_L$ )

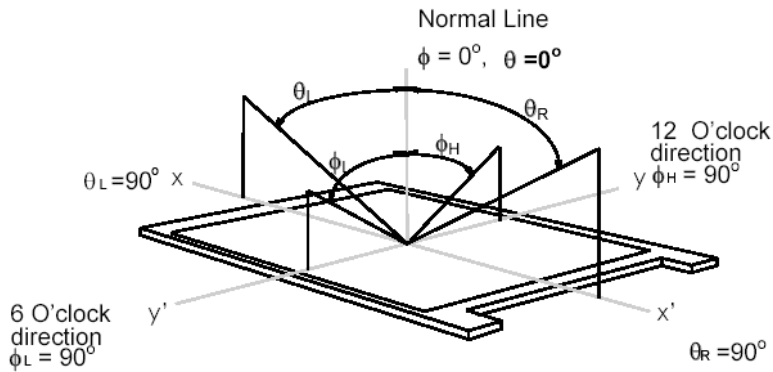

**Note 2-6: Response time measurement**

The output signals of photo detector are measured when the input signals are changed from “Full Black” to “Full White” (rising time,  $T_{rF}$ ), and from “Full White” to “Full Black” (falling time,  $T_{rB}$ ), respectively. The response time is interval between the 10% and 90% (1 frame at 60 Hz) of amplitudes.

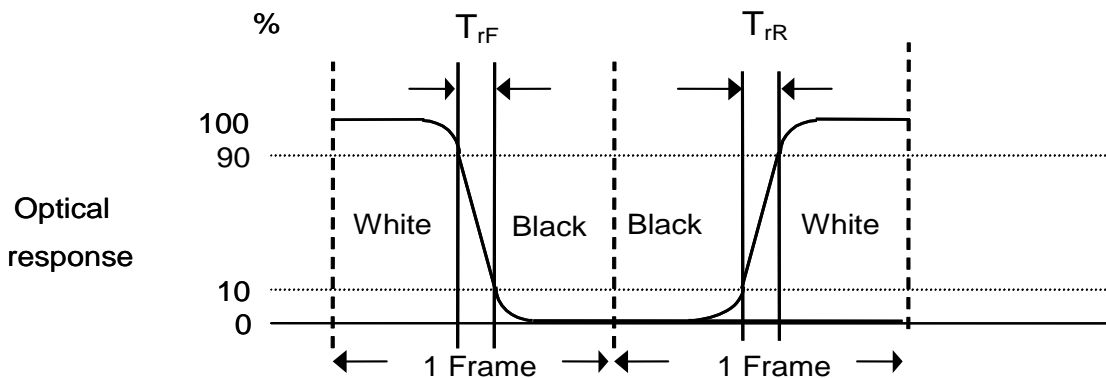

$T_{rR} + T_{rF} = 12 \text{ msec (typ.)}$ .

**Note 2-7: Crosstalk measurement**

**Definition:**

$$CT = \text{Max. } (CT_H, CT_V);$$

Where

a. Maximum Horizontal Crosstalk :

$$CT_H = \text{Max. } (| Y_{BL} - Y_{AL} | / Y_{AL} \times 100 \%, | Y_{BR} - Y_{AR} | / Y_{AR} \times 100 \%);$$

Maximum Vertical Crosstalk:

$$CT_V = \text{Max. } (| Y_{BU} - Y_{AU} | / Y_{AU} \times 100 \%, | Y_{BD} - Y_{AD} | / Y_{AD} \times 100 \%);$$

b.  $Y_{AU}, Y_{AD}, Y_{AL}, Y_{AR}$  = Luminance of measured location without Black pattern

$Y_{BU}, Y_{BD}, Y_{BL}, Y_{BR}$  = Luminance of measured location with Black pattern

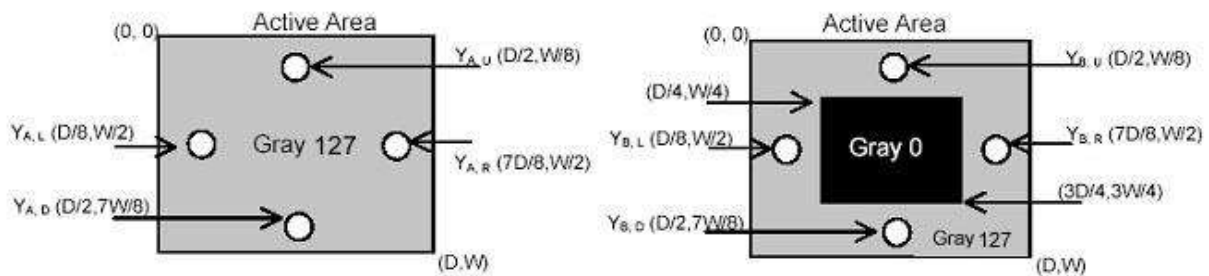

**Note 2-8: Flicker measurement**

a. Test pattern: It is listed as following.

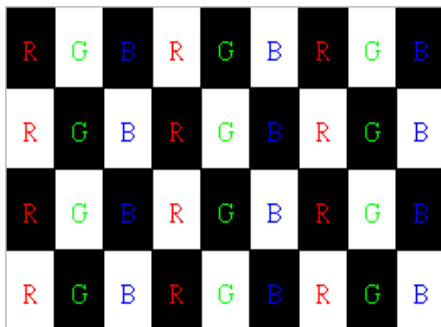

Gray level = L0



Gray level = L127

**R:** Red, **G:** Green, **B:**Blue

b. Measured position: Center of screen (P5) & perpendicular to the screen ( $\theta = \Phi = 0^\circ$ )

## 2.4 Mechanical Characteristics

Symbol	Description	Min.	Max.	Unit	Remark
P <sub>bc</sub>	Backside Compression	2.5	-	[Kgf]	<b>Note 2-9</b>

### Note 2-9: Test Method:

The point is at a distance from right-downside 25mm x 25mm defined as the Start Point of Measure Points, and the point is at a distance 25mm from left-side & around 10mm from PCB defined as the End Point.

Align 50mm x 50mm block from Start Point on the Bezel Back, and the corners of each block are Measure Points.

If the distance from the last block to each side of the End Point  $\geq 25$ mm, add other blocks to make sure that most area of Bezel Back can be measured.

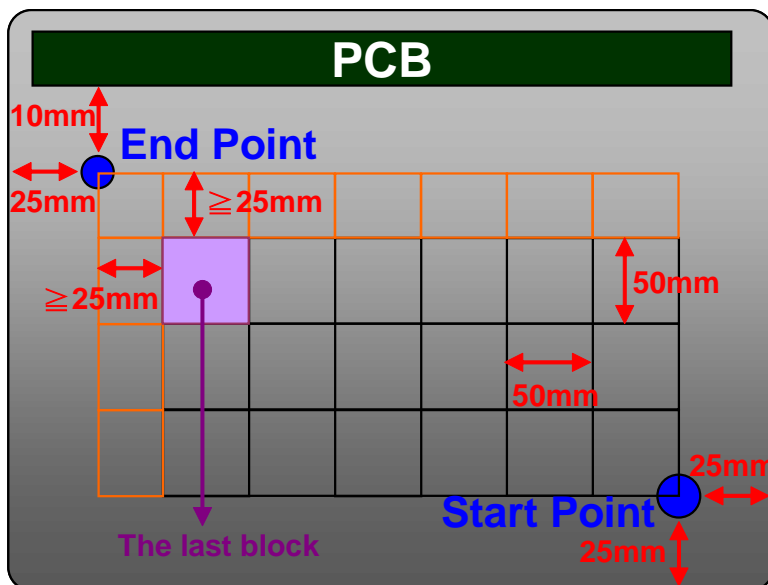

### 3 TFT-LCD Module

#### 3.1 Block Diagram

The following shows the block diagram of the 27 inch Color TFT-LCD Module.

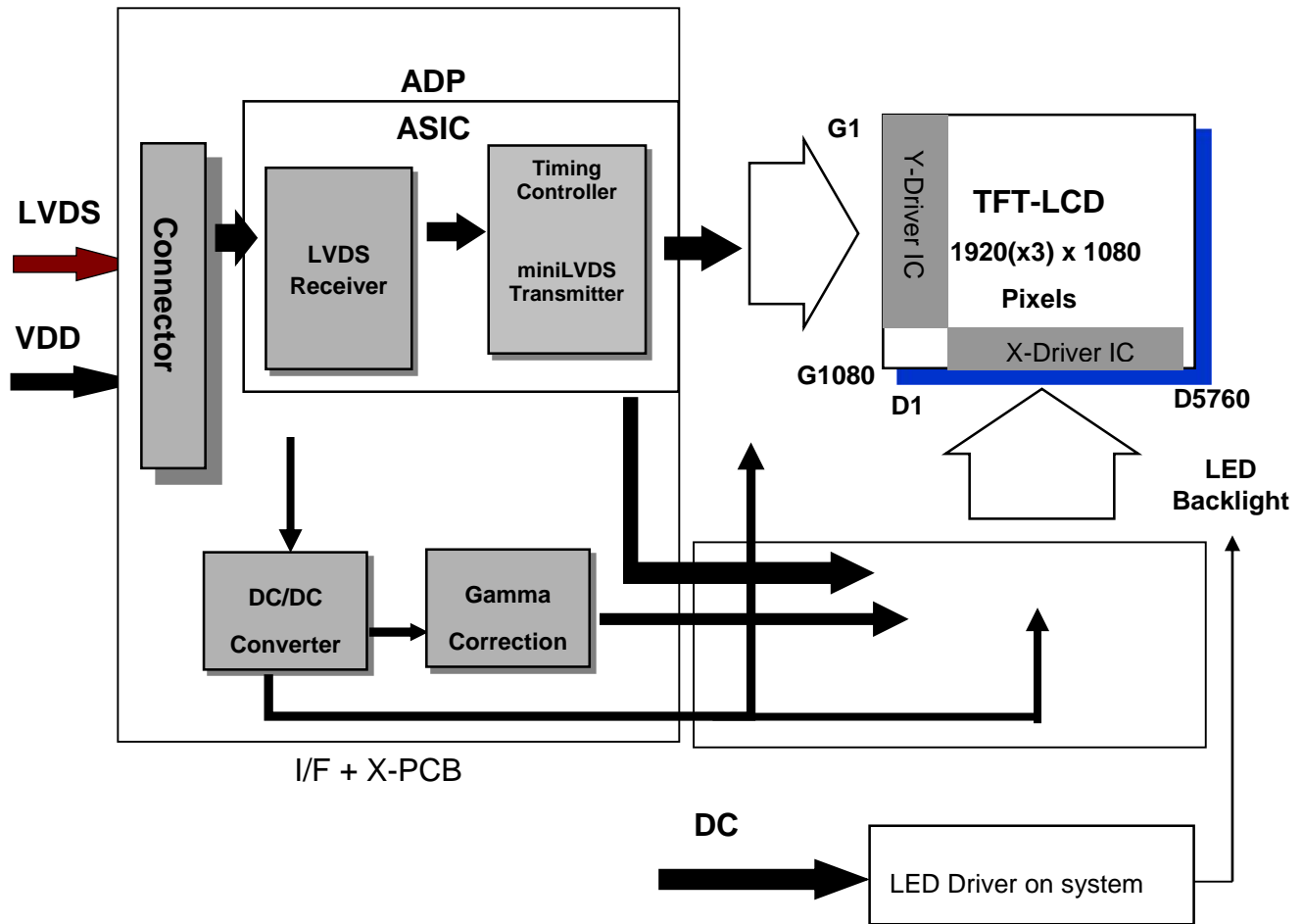

### 3.2 Interface Connection

#### 3.2.1 Connector Type

TFT-LCD Connector	Manufacturer	P-TWO	STM	STARCONN
	Part Number	AL230F-A0G1D-P	MSCKT2407P30HB	093G30-02001A-M4
Mating Connector	Manufacturer	JAE or Compatible		
	Part Number	FI-X30HL (Locked Type)		

#### 3.2.2 Connector Pin Assignment

PIN #	SIGNAL NAME	DESCRIPTION
1	RXO0-	Negative LVDS differential data input (Odd data)
2	RXO0+	Positive LVDS differential data input (Odd data)
3	RXO1-	Negative LVDS differential data input (Odd data)
4	RXO1+	Positive LVDS differential data input (Odd data)
5	RXO2-	Negative LVDS differential data input (Odd data, H-Sync,V-Sync,DSPTMG)
6	RXO2+	Positive LVDS differential data input (Odd data, H-Sync,V-Sync,DSPTMG)
7	GND	Power Ground
8	RXOCLK-	Negative LVDS differential clock input (Odd clock)
9	RXOCLK+	Positive LVDS differential clock input (Odd clock)
10	RXO3-	Negative LVDS differential data input (Odd data)
11	RXO3+	Positive LVDS differential data input (Odd data)
12	RXE0-	Negative LVDS differential data input (Even data)
13	RXE0+	Positive LVDS differential data input (Even data)
14	GND	Power Ground
15	RXE1-	Negative LVDS differential data input (Even data)
16	RXE1+	Positive LVDS differential data input (Even data)
17	GND	Power Ground
18	RXE2-	Negative LVDS differential data input (Even data)
19	RXE2+	Positive LVDS differential data input (Even data)
20	RXECLK-	Negative LVDS differential clock input (Even clock)
21	RXECLK+	Positive LVDS differential clock input (Even clock)
22	RXE3-	Negative LVDS differential data input (Even data)
23	RXE3+	Positive LVDS differential data input (Even data)
24	GND	Power Ground
25	NC	No contact
26	NC	No contact
27	NC	No contact
28	VDD	+5.0V Power Supply

29	VDD	+5.0V Power Supply
30	VDD	+5.0V Power Supply

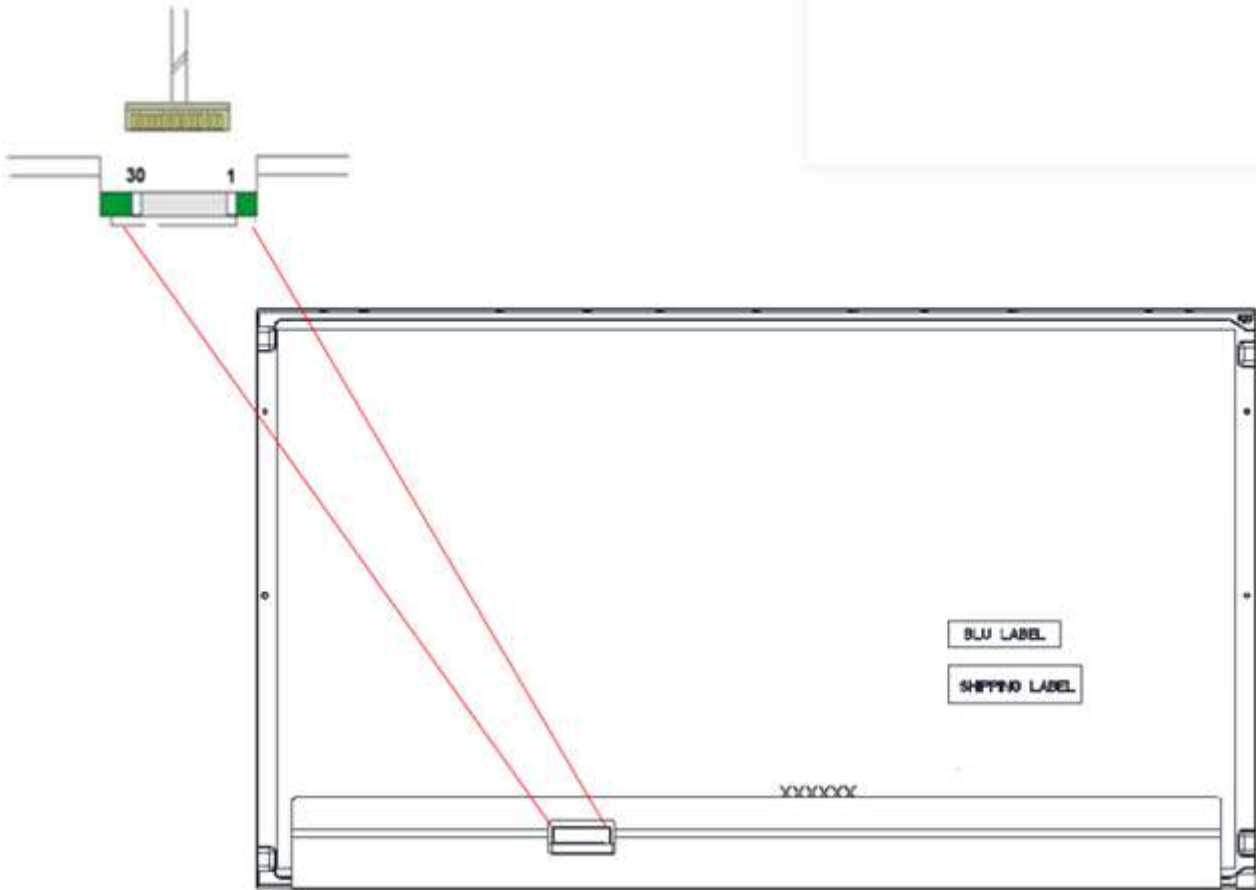



### 3.3 Electrical Characteristics

#### 3.3.1 Absolute Maximum Rating

Permanent damage may occur if exceeding the following maximum rating.

Symbol	Description	Min	Max	Unit	Remark
VDD	Power Supply Input Voltage	GND-0.3	6.0	[Volt]	Ta=25°C

#### 3.3.2 Recommended Operating Condition

Symbol	Description	Min	Typ	Max	Unit	Remark
VDD	Power supply Input voltage	4.5	5.0	5.5	[Volt]	
IDD	Power supply Input Current (RMS)	-	0.93	1.22	[A]	VDD= 5.0V, All white Pattern at 60 Hz
			1.22	1.46	[A]	VDD= 5.0V, All white Pattern at 75 Hz
PDD	VDD Power Consumption	-	4.65	6.1	[Watt]	VDD= 5.0V, All white Pattern at 60 Hz
			6.10	7.30	[Watt]	VDD= 5.0V, All white Pattern at 75 Hz
IRush	Inrush Current	-	-	3.0	[A]	<b>Note 3-1</b>
VDDrp	Allowable VDD Ripple Voltage	-	-	500	[mV]	VDD= 5.0V, All white Pattern at 75 Hz

**Note 3-1:** Inrush Current measurement:

Test circuit:

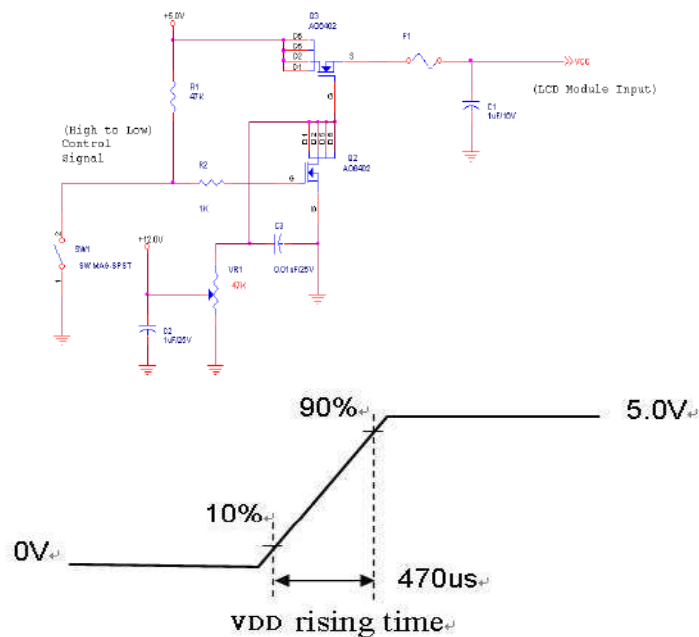

The duration of VDD rising time: 470us.

### 3.4 Signal Characteristics

#### 3.4.1 LCD Pixel Format

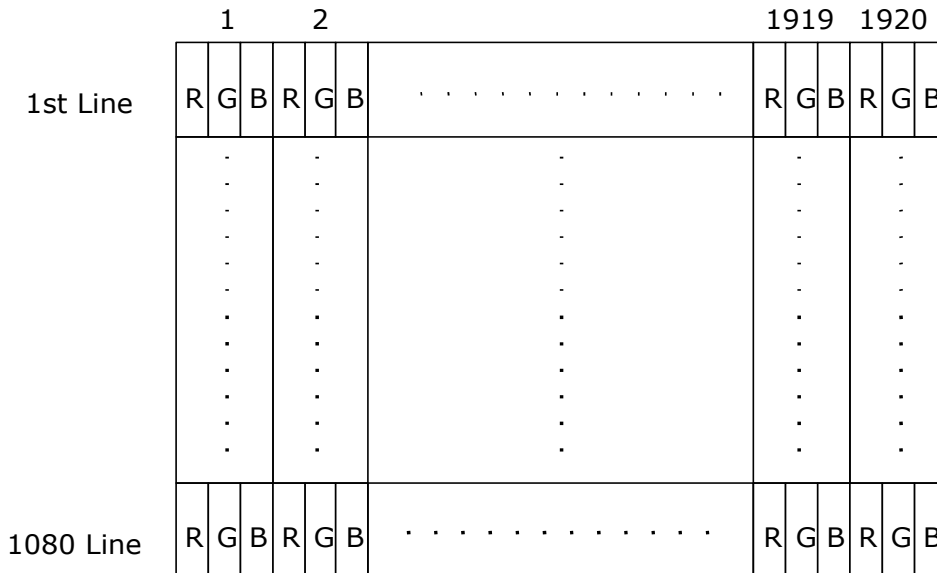

#### 3.4.2 LVDS Data Format

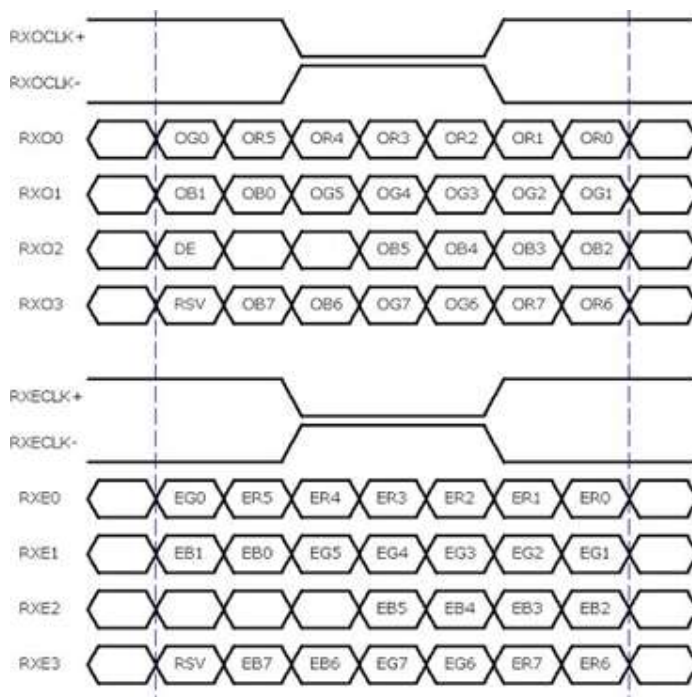

8 Bit Color Bit Order			
<b>MSB</b>	R7	G7	B7
	R6	G6	B6
	R5	G5	B5
	R4	G4	B4
	R3	G3	B3
	R2	G2	B2
	R1	G1	B1
<b>LSB</b>	R0	G0	B0

**Note 3-2:**

- a. O = "Odd Pixel Data"    E = "Even Pixel Data"
- b. Refer to 3.4.1 LCD pixel format, the 1st data is 1 (Odd Pixel Data), the 2<sup>nd</sup> data is 2 (Even Pixel Data) and the last data is 1920 (Even Pixel Data).

### 3.4.3 Color versus Input Data

The following table is for color versus input data (8bit). The higher the gray level, the brighter the color.

Color	Gray Level	Color Input Data																				Remark				
		RED data (MSB:R7, LSB:R0)								GREEN data (MSB:G7, LSB:G0)								BLUE data (MSB:B7, LSB:B0)								
		R7	R6	R5	R4	R3	R2	R1	R0	G7	G6	G5	G4	G3	G2	G1	G0	B7	B6	B5	B4		B3	B2	B1	B0
Black	-	0	0	0	0	0	0	0	0	0	0	0	0	0	0	0	0	0	0	0	0	0	0	0		
White	-	1	1	1	1	1	1	1	1	1	1	1	1	1	1	1	1	1	1	1	1	1	1	1		
Gray 127	-	0	1	1	1	1	1	1	1	0	1	1	1	1	1	1	1	0	1	1	1	1	1	1		
Red	L0	0	0	0	0	0	0	0	0	0	0	0	0	0	0	0	0	0	0	0	0	0	0	0	Black	
	:	:	:	:	:	:	:	:	:	:	:	:	:	:	:	:	:	:	:	:	:	:	:	:		
	L255	1	1	1	1	1	1	1	1	0	0	0	0	0	0	0	0	0	0	0	0	0	0	0		
Green	L0	0	0	0	0	0	0	0	0	0	0	0	0	0	0	0	0	0	0	0	0	0	0	0	Black	
	:	:	:	:	:	:	:	:	:	:	:	:	:	:	:	:	:	:	:	:	:	:	:	:		
	L255	0	0	0	0	0	0	0	0	0	1	1	1	1	1	1	1	0	0	0	0	0	0	0		
Blue	L0	0	0	0	0	0	0	0	0	0	0	0	0	0	0	0	0	0	0	0	0	0	0	0	Black	
	:	:	:	:	:	:	:	:	:	:	:	:	:	:	:	:	:	:	:	:	:	:	:	:		
	L255	0	0	0	0	0	0	0	0	0	0	0	0	0	0	0	0	1	1	1	1	1	1	1		

### 3.4.4 LVDS Specification

#### a. DC Characteristics:

Symbol	Description	Min	Typ	Max	Units	Condition
$V_{TH}$	LVDS Differential Input High Threshold	-	-	+100	[mV]	$V_{CM} = 1.2V$
$V_{TL}$	LVDS Differential Input Low Threshold	-100	-	-	[mV]	$V_{CM} = 1.2V$
$ V_{ID} $	LVDS Differential Input Voltage	100	-	600	[mV]	
$V_{CM}$	LVDS Common Mode Voltage	+1.0	+1.2	+1.5	[V]	$V_{TH}-V_{TL} = 200mV$ (max)

**LVDS Signal Waveform:**

Use RxOCLK- & RxOCLK+ as example.

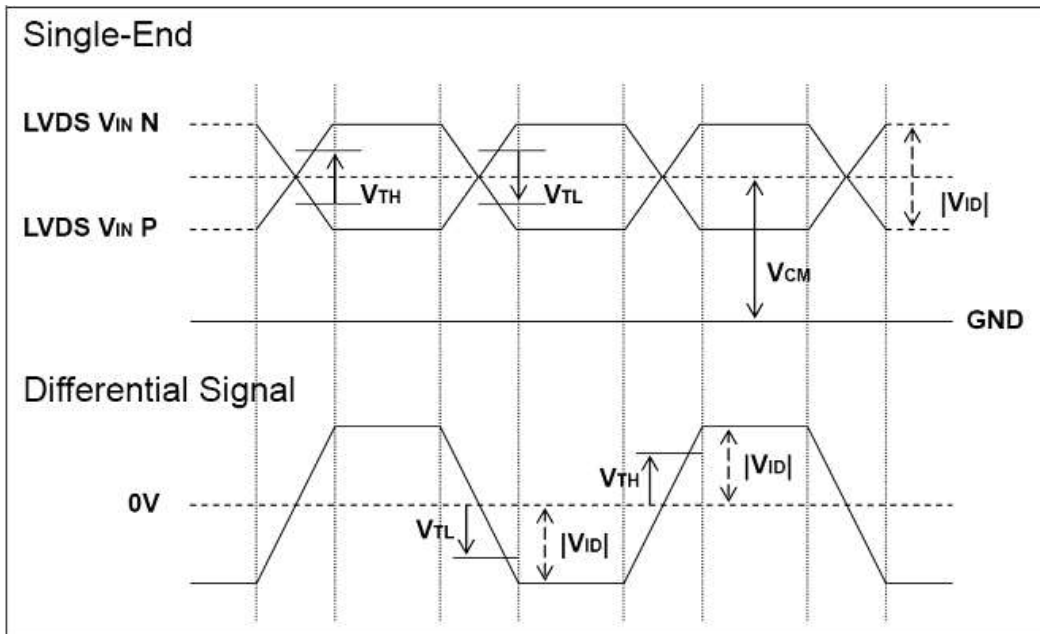

**b. AC Characteristics:**

Symbol	Description	Min	Max	Unit	Remark
$F_{DEV}$	Maximum deviation of input clock frequency during Spread Spectrum	-	$\pm 3$	%	
$F_{MOD}$	Maximum modulation frequency of input clock during Spread Spectrum	-	200	KHz	

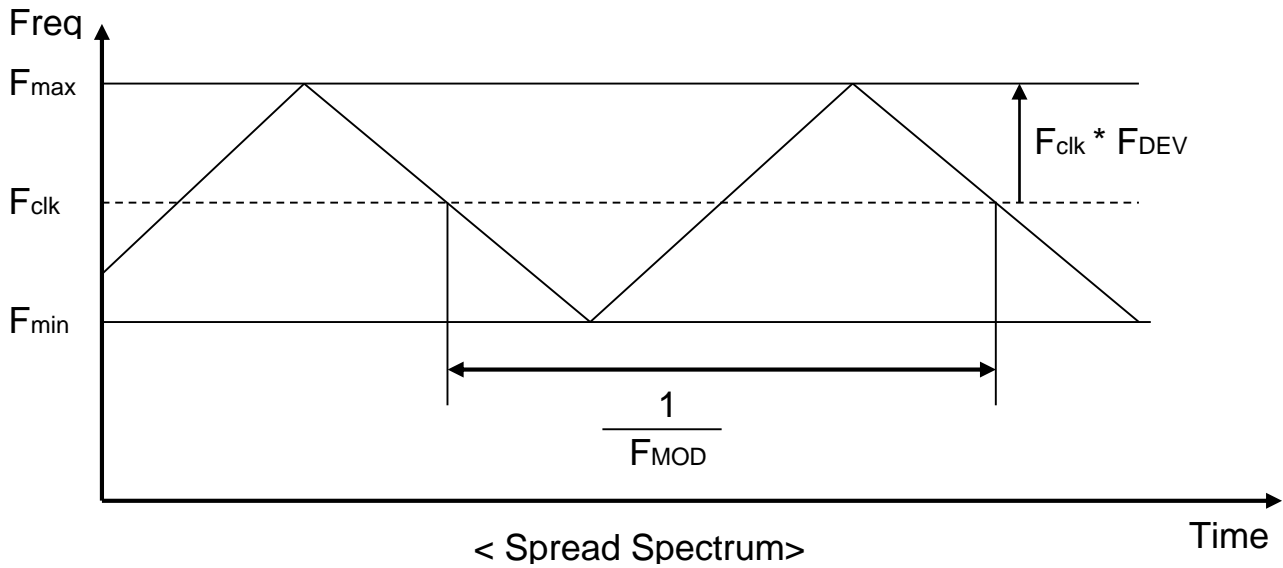

Fclk: LVDS Clock Frequency

### 3.4.5 Input Timing Specification

It only support DE mode, and the input timing are shown as the following table.

Symbol	Description		Min.	Typ.	Max.	Unit	Remark
Tv	Vertical Section	Period	1092	1130	1793	Th	
Tdisp (v)		Active	1080	1080	1080	Th	
Tblk (v)		Blanking	12	50	713	Th	
Fv		Frequency	50	60	76	Hz	Note 3-3
Th	Horizontal Section	Period	1004	1050	1100	Tclk	
Tdisp (h)		Active	960	960	960	Tclk	
Tblk (h)		Blanking	44	90	140	Tclk	
Fh		Frequency	55	68	90	KHz	Note 3-4
Tclk	LVDS Clock	Period	11.1	14.0	18.2	ns	1/Fclk
Fclk		Frequency	54.8	71.2	90.0	MHz	Note 3-5

Note 3-3: The optimal Vertical Frequency is 50~76 Hz for best picture.

Note 3-4: The equation is listed as following. Please don't exceed the above recommended value.

$$F_h (\text{Min.}) = F_{\text{clk}} (\text{Min.}) / T_h (\text{Min.});$$

$$F_h (\text{Typ.}) = F_{\text{clk}} (\text{Typ.}) / T_h (\text{Typ.});$$

$$F_h (\text{Max.}) = F_{\text{clk}} (\text{Max.}) / T_h (\text{Min.});$$

Note 3-5: The equation is listed as following. Please don't exceed the above recommended value.

$$F_{\text{clk}} (\text{Min.}) = F_v (\text{Min.}) \times T_h (\text{Min.}) \times T_v (\text{Min.});$$

$$F_{\text{clk}} (\text{Typ.}) = F_v (\text{Typ.}) \times T_h (\text{Typ.}) \times T_v (\text{Typ.});$$

$$F_{\text{clk}} (\text{Max.}) = F_v (\text{Max.}) \times T_h (\text{Typ.}) \times T_v (\text{Typ.});$$

### 3.4.6 Input Timing Diagram

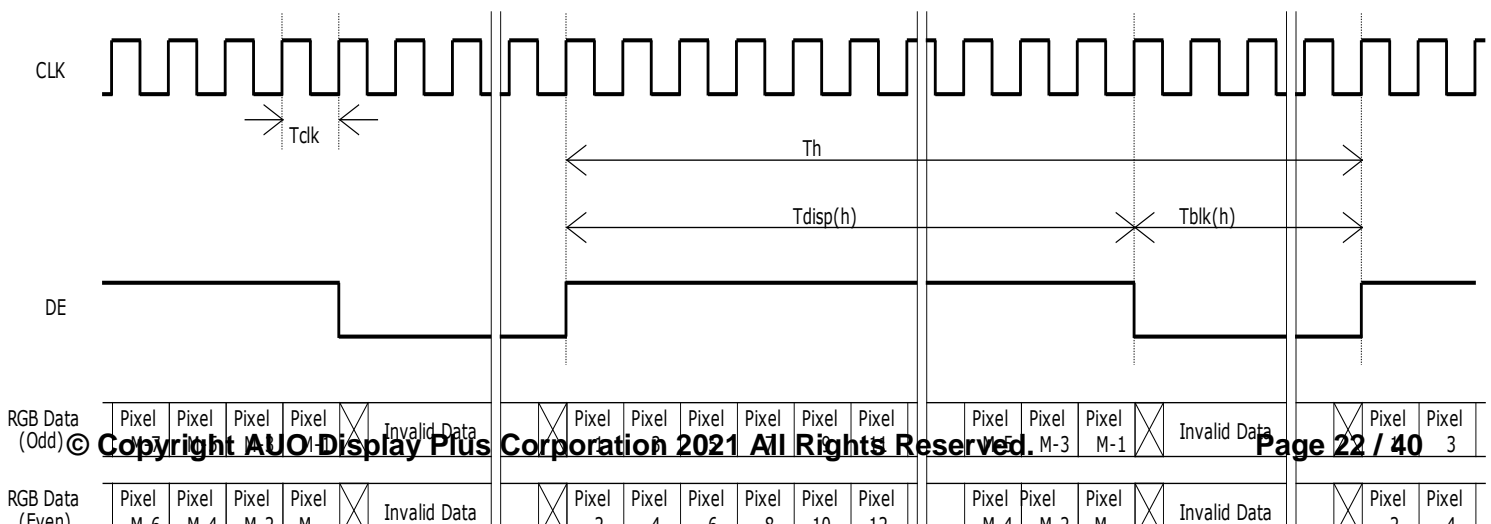
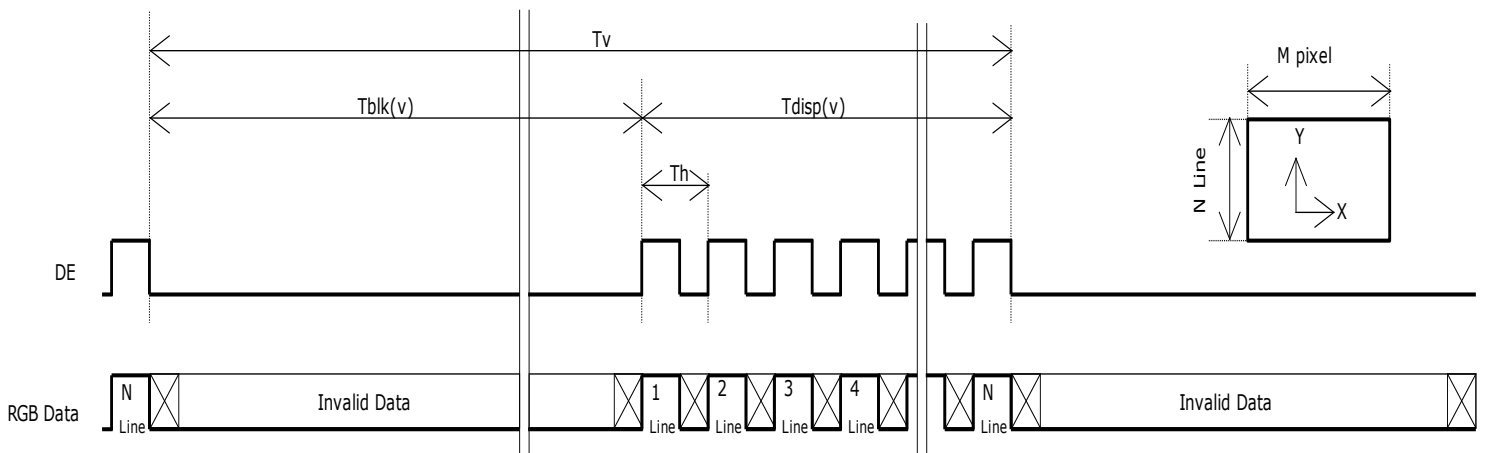

### 3.5 Power ON/OFF Sequence

VDD power, LVDS signal and backlight on/off sequence are as following. LVDS signals from any system shall be Hi-Z state when VDD is off.

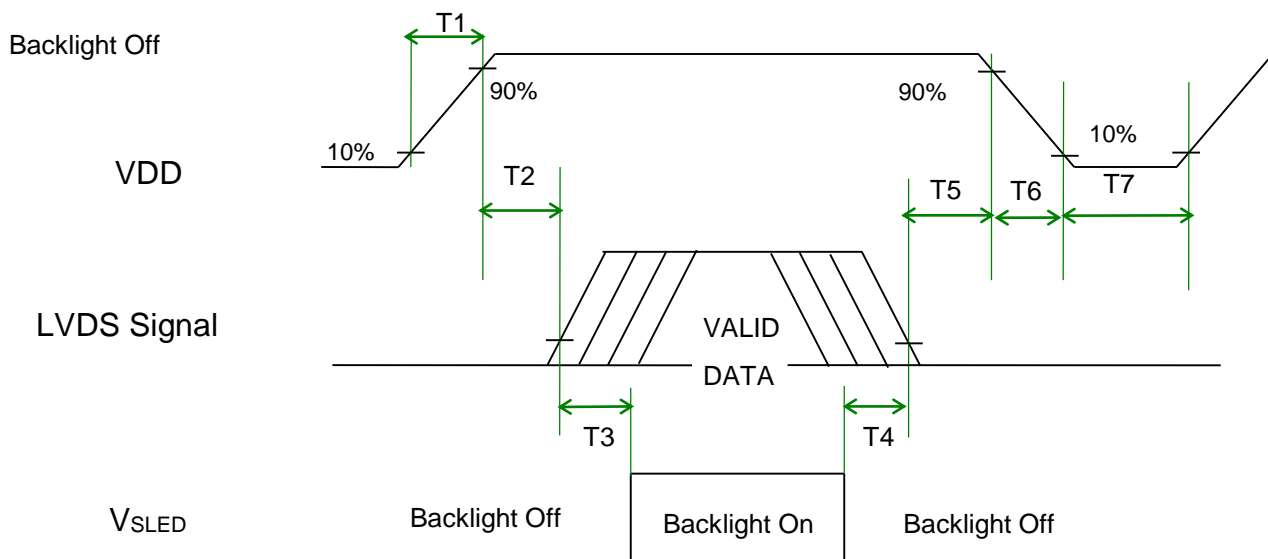

Power Sequence Timing

Symbol	Value			Unit	Remark
	Min.	Typ.	Max.		
T1	0.5	-	10	[ms]	
T2	0	-	50	[ms]	
T3	500	-	-	[ms]	
T4	100	-	-	[ms]	

T5	0		50	[ms]	<b>Note 3-6</b> <b>Note 3-7</b>
T6	0	-	200	[ms]	<b>Note 3-7</b> <b>Note 3-8</b>
T7	1000	-	-	[ms]	

**Note 3-6** : Recommend setting T5 = 0ms to avoid electronic noise when VDD is off.

**Note 3-7** : During T5 and T6 period , please keep the level of input LVDS signals with Hi-Z state.

**Note 3-8** : Voltage of VDD must decay smoothly after power-off. (customer system decide this value)

## 4 Backlight Unit

### 4.1 Block Diagram

The following shows the block diagram of the 27 inch Backlight Unit. And it includes 116pcs LED in the LED light bar. (4 strings and 29 pcs LED of one string).



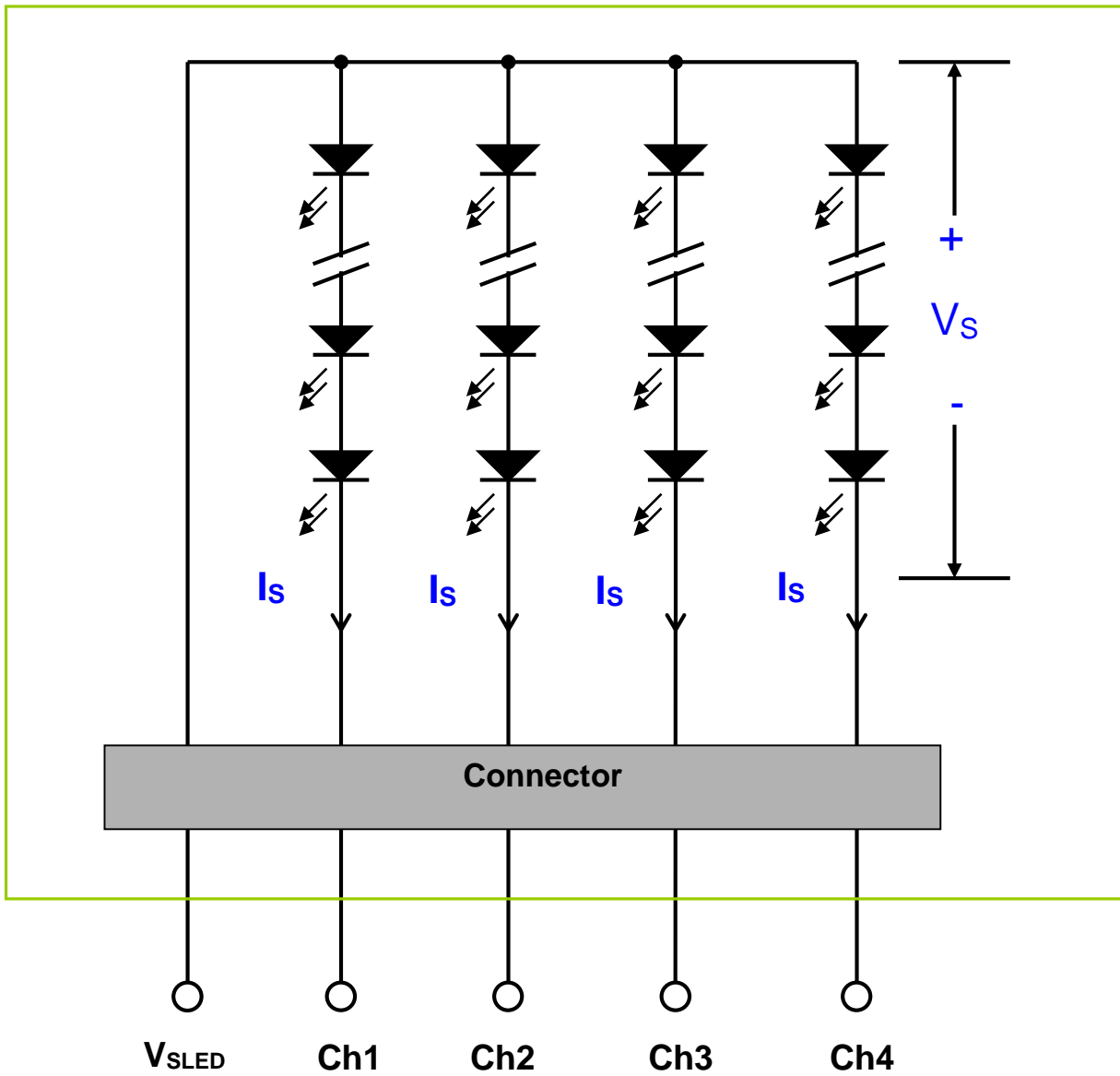

## 4.2 Interface Connection

### 4.2.1 Connector Type

Backlight Connector	Manufacturer	CVILUX
	Part Number	CI1406M1HRN-NH1
Mating Connector	Manufacturer	CVILUX or Compatible

	<b>Part Number</b>	<b>C11406SL000-NH (Lock)</b>
--	--------------------	------------------------------

#### 4.2.2 Connector Pin Assignment

Pin#	Symbol	Description	Remark
1	Ch1	LED Current Feedback Terminal (Channel 1)	
2	Ch2	LED Current Feedback Terminal (Channel 2)	
3	V <sub>SLED</sub>	LED Power Supply Voltage Input Terminal	
4	V <sub>SLED</sub>	LED Power Supply Voltage Input Terminal	
5	Ch3	LED Current Feedback Terminal (Channel 3)	
6	Ch4	LED Current Feedback Terminal (Channel 4)	

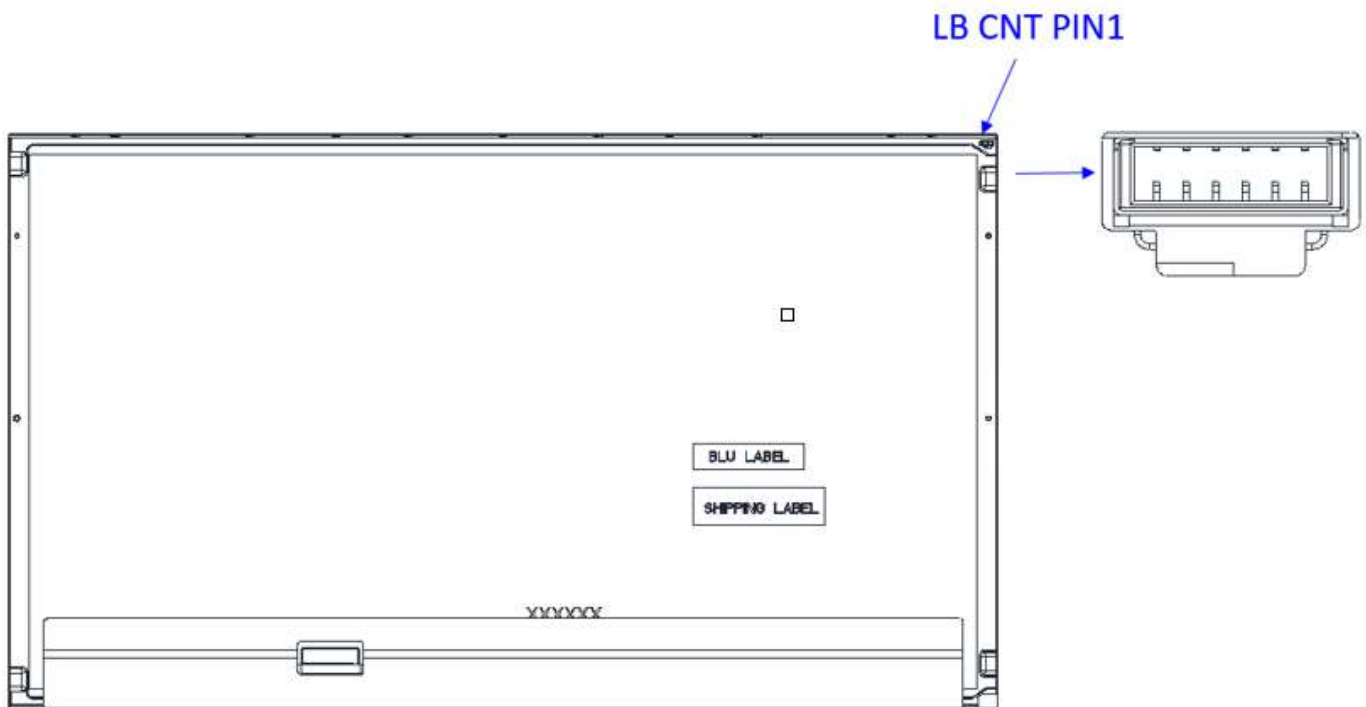

#### 4.3 Electrical Characteristics

##### 4.3.1 Absolute Maximum Rating

Permanent damage may occur if exceeding the following maximum rating.

(Ta=25°C)

Symbol	Description	Min	Max	Unit	Remark
I <sub>s</sub>	LED String Current	0	180	[mA]	100% duty ratio

			360	[mA]	Duty ratio $\leq 10\%$ Pulse time=10 ms
--	--	--	-----	------	--

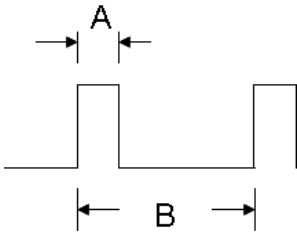

Duty ratio = (A / B) X 100% ; (A: Pulse time, B: Period)

### 4.3.2 Recommended Operating Condition

(Ta=25°C)

Symbol	Description	Min.	Typ.	Max.	Unit	Remark
Is	LED String Current	-	65	72	[mA]	100% duty ratio of LED chip <b>Note 4-7</b>
Vs	LED String Voltage	75.7	82.7	87.6	[Volt]	Is=65mA @ 100% duty ratio; <b>Note 4-1, Note 4-5</b>
$\Delta V_s$	Maximum Vs Voltage Deviation of light bar	-	-	5.8	[Volt]	Is=65mA @ 100% duty ratio; <b>Note 4-2</b>
P <sub>BLU</sub>	LED Light Bar Power Consumption	-	21.5	22.77	[Watt]	<b>Note 4-3</b>
LT <sub>LED</sub>	LED MTTF		50,000	-	[Hour]	<b>Note 4-4</b>
OVP	Over Voltage Protection in system board	110% V <sub>smax</sub>	-	-	[Volt]	<b>Note 4-5</b>

**Note 4-1:** Vs (Typ.) = V<sub>F</sub> (Typ.) X LED No. (one string);

a. V<sub>F</sub>: LED chip forward voltage, V<sub>F</sub> (Min.)=2.61V, V<sub>F</sub>(Typ.)=2.85V, V<sub>F</sub>(Max.)=3.02V

b. The same equation to calculate Vs(Min.) & Vs (Max.) for respective V<sub>F</sub> (Min.) & V<sub>F</sub>(Max.);

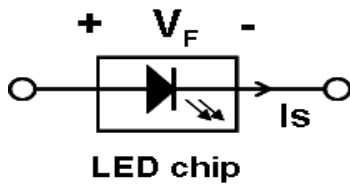

**Note 4-2:**  $\Delta V_s$  (Max.) =  $\Delta V_F \times \text{LED No. (one string)}$ ;

a.  $\Delta V_F$ : LED chip forward voltage deviation; (0.2 V , each Bin of LED  $V_F$ )

**Note 4-3:**  $P_{BLU}$  (Typ.) =  $V_s$  (Typ.)  $\times I_s$  (Typ.)  $\times 4$  ; ( 4 is total String No. of LED Light bar)

$P_{BLU}$  (Max.) =  $V_s$  (Max.)  $\times I_s$  (Typ.)  $\times 4$  ;

**Note 4-4:** LED MTTF is defined as the time which luminance of LED is 50% compared to its original value. [Operating condition: Continuous operating at  $T_a = 25 \pm 2^\circ\text{C}$  , for single LED only] MTTF is a reference index, it is not representative of warranty.

**Note 4-5:** Recommendation for LED driver power design:

Due to there are electrical property deviation in LED & monitor set system component after long time operation. ADP strongly recommend the design value of LED driver board OVP (over voltage protection) should be 10% higher than max. value of LED string voltage ( $V_s$ ) at least.

**Note 4-6:** ADP strongly recommend “Analog Dimming” method for backlight brightness control for Wavy Noise Free. Otherwise, recommend that Dimming Control Signal (PWM Signal) should be synchronized with Frame Frequency.

**Note 4-7** Ensure that the LED light bar is not subjected either forward or reverse voltage while monitor set is on standby mode or not in use.

## 5 Reliability Test

ADP reliability test items are listed as following table. (*Bare Panel only*)

	Test Item	Q'ty	Condition
1	High temperature storage test	3	60°C, 500hrs

2	Low temperature storage test	3	-20°C, 500hrs
3	High temperature operation test	3	50°C, 500hrs
4	High temperature and High humidity operation (THB)	3	50°C, 80%, 500hrs
5	Low temperature operation test	3	0°C, 500hrs
6	Vibration test (With carton)	1( PKG)	Random wave (1.04Grms 2~200Hz) Duration : X,Y,Z 20min per axes
7	Drop test (With carton)	1( PKG)	Height: 38.1 cm Direction: 1 corner 3 edges 6flats (ASTM D 4169 & D5276)

## 6 Shipping Label

### 6.1 Shipping Label

The label on the panel is shown as below:



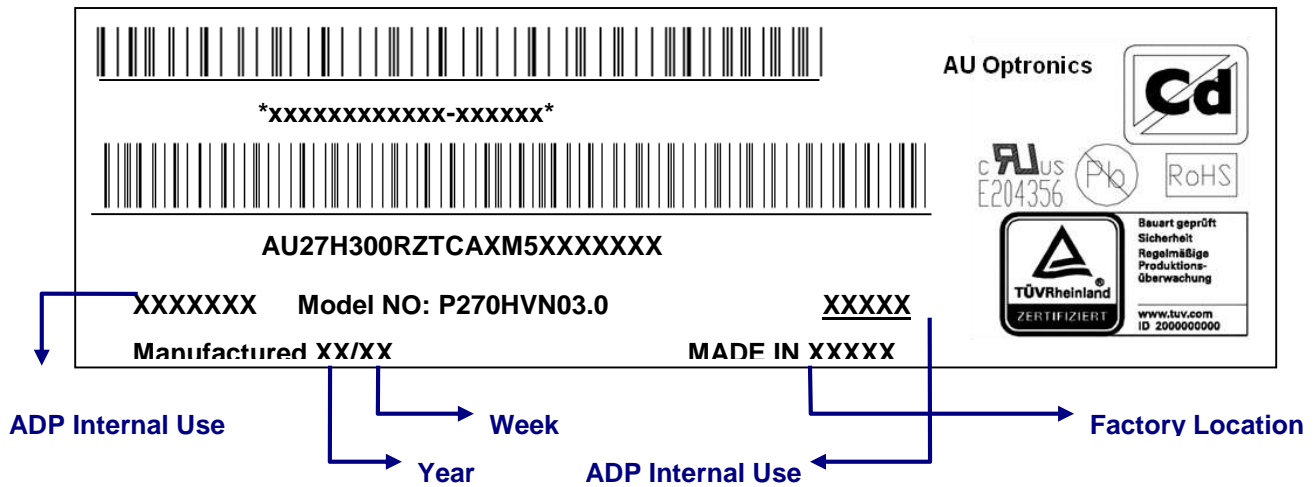

**Note 6-1:** For Pb Free products, ADP will add for identification.

**Note 6-2:** For RoHS compatible products, ADP will add for identification.

**Note 6-3:** For China RoHS compatible products, ADP will add for identification.

**Note 6-4:** The Green Mark will be presented only when the green documents have been ready by ADP Internal Green Team.

**6.2 Cartoon Label**

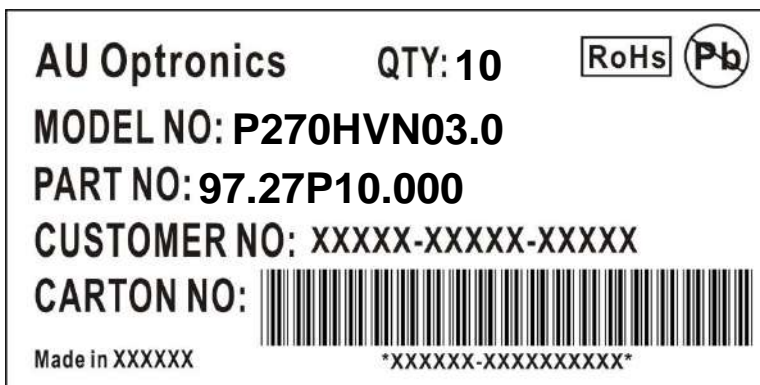

**7 Mechanical Characteristics**

Front View

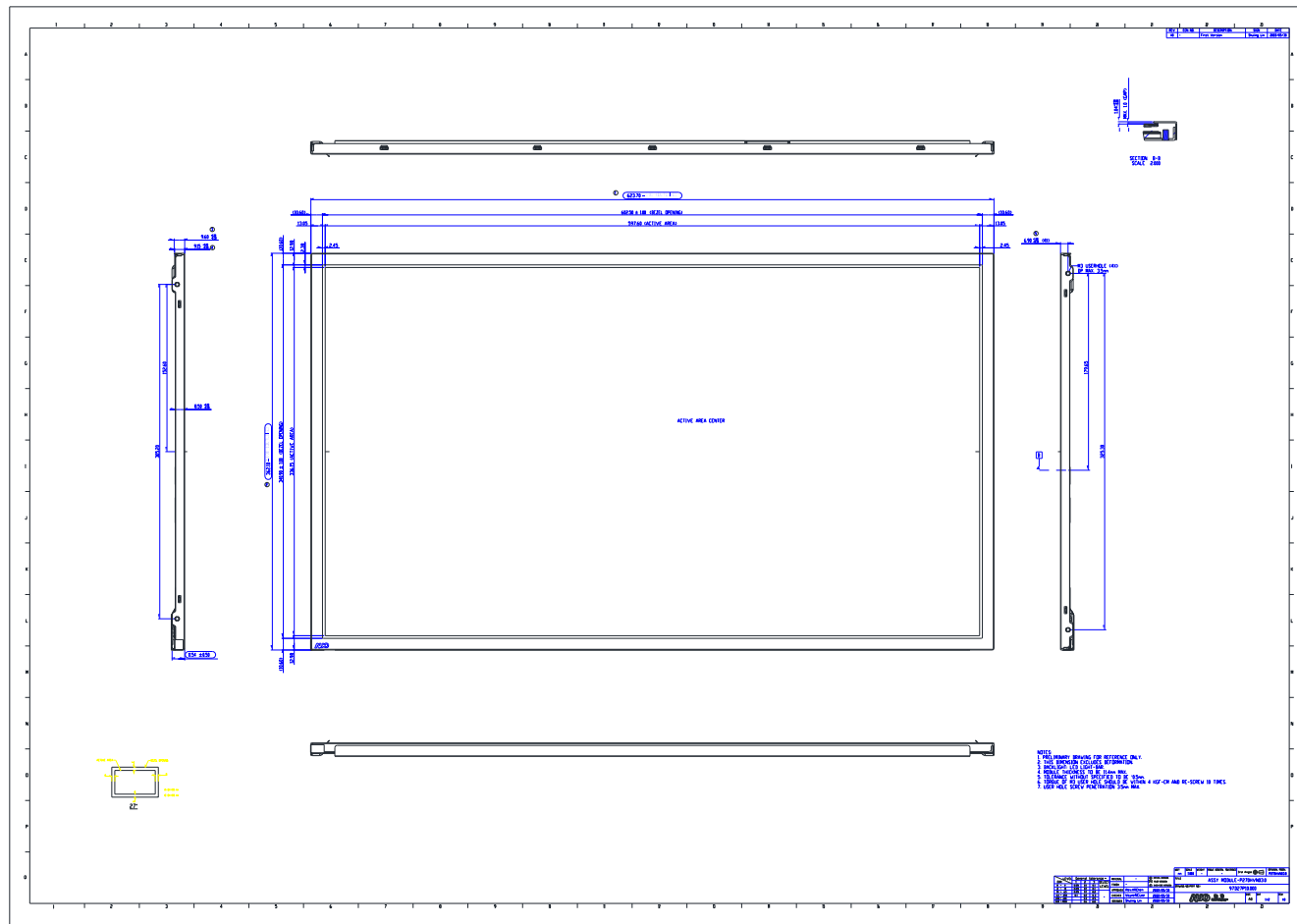

Back View

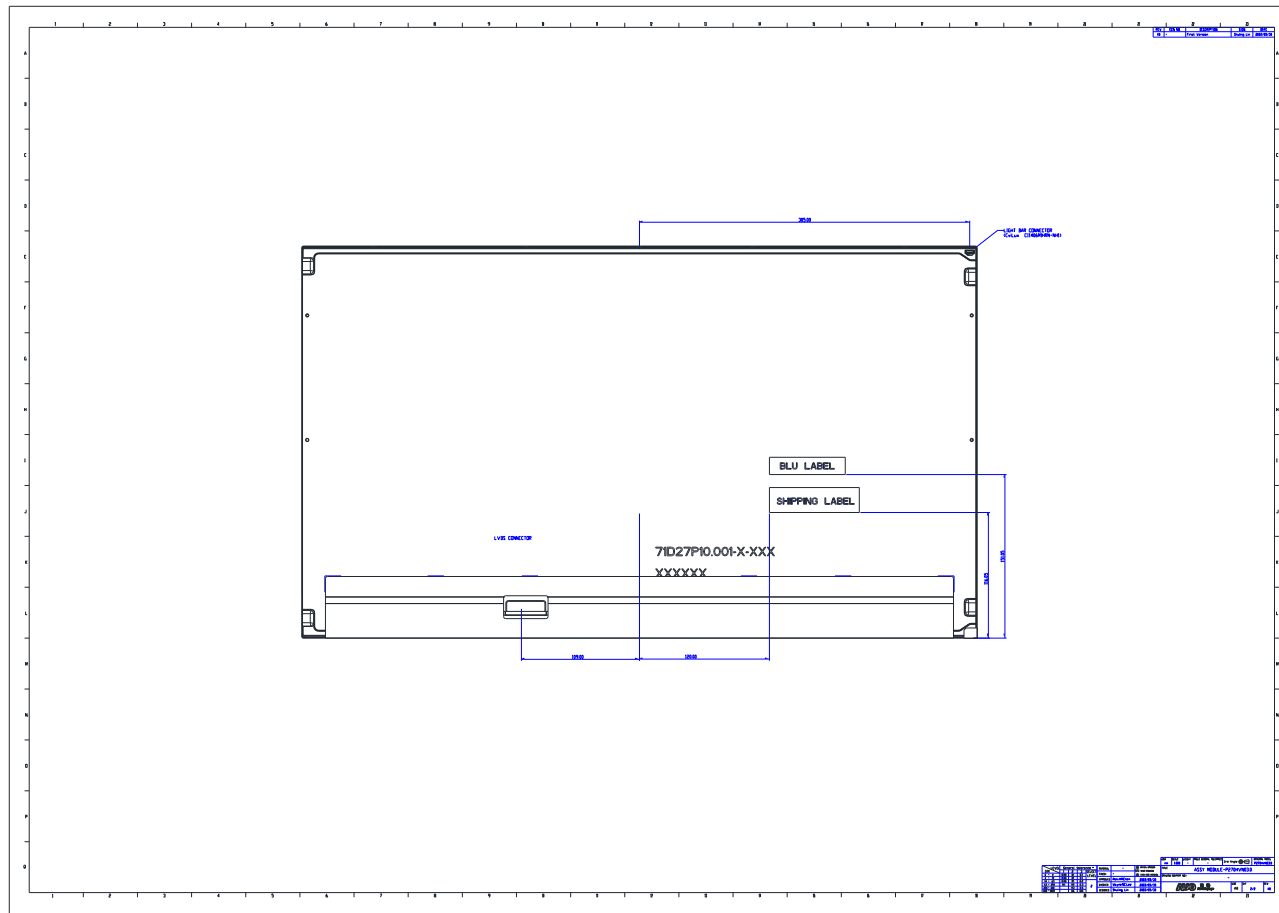



COF Position

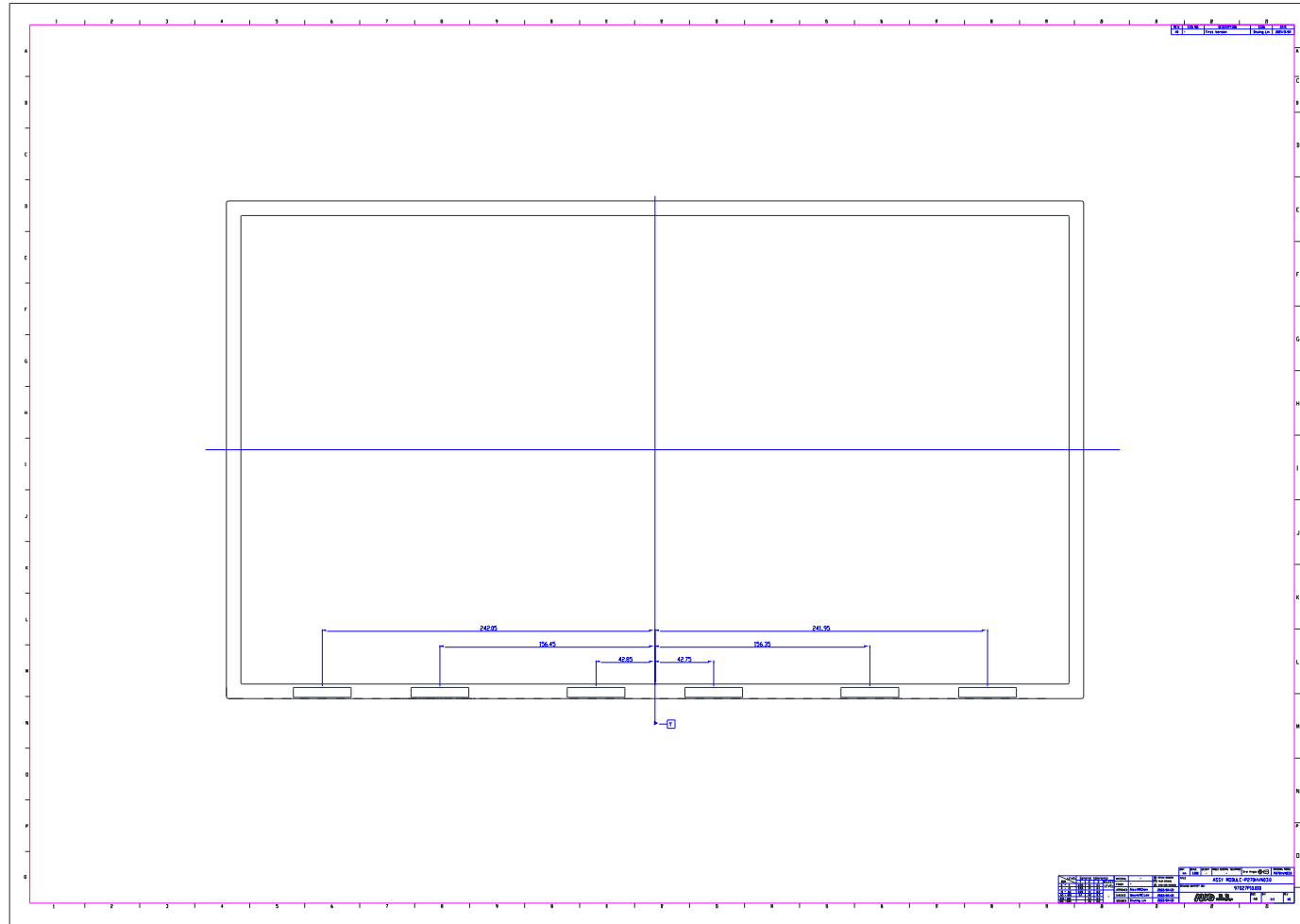

## 8 Packing Specification

### 8.1 Packing Flow

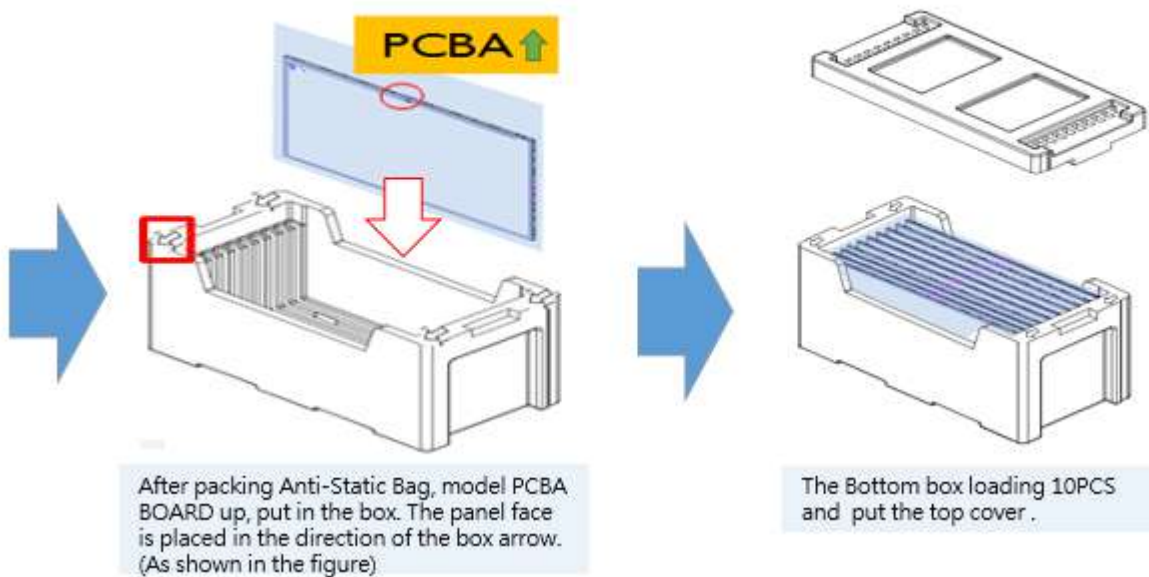
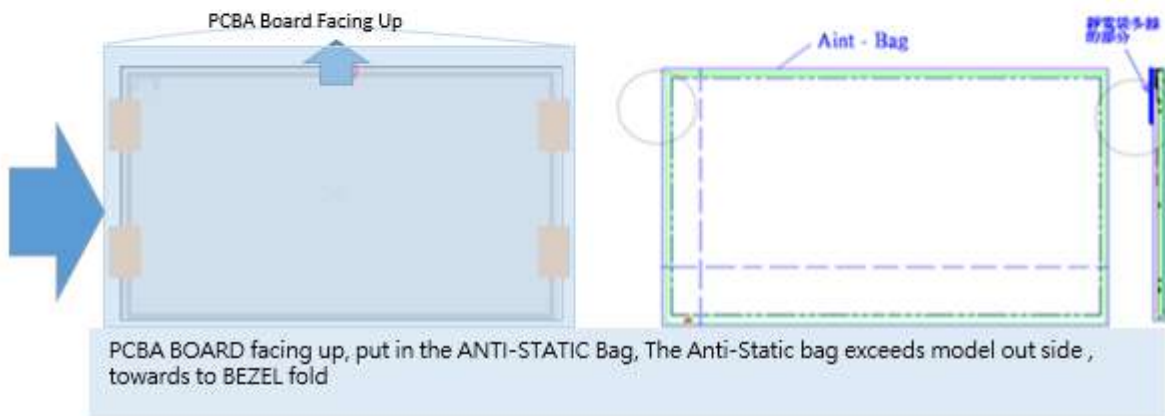
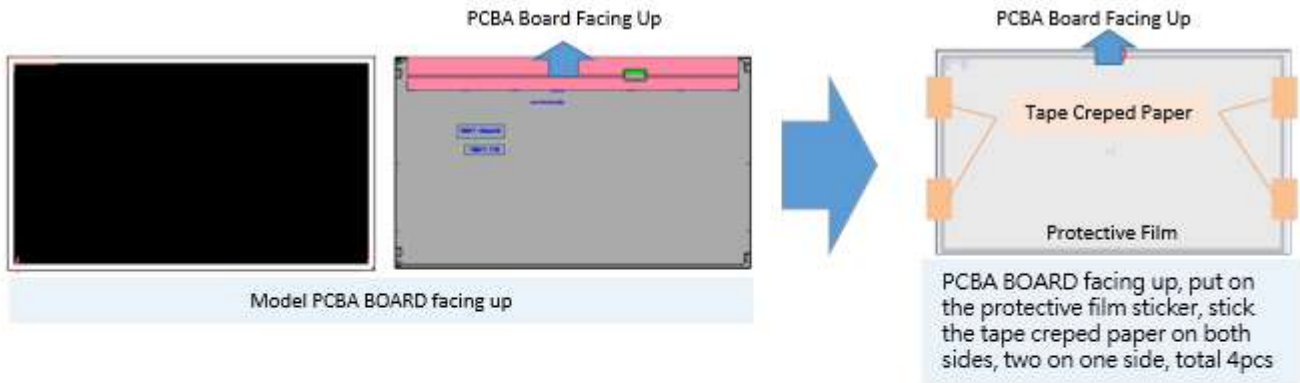

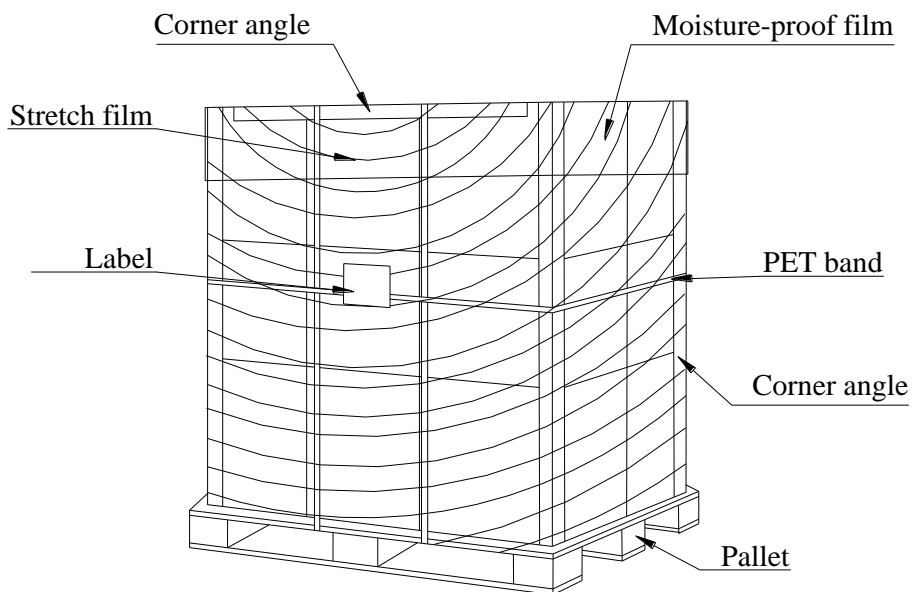
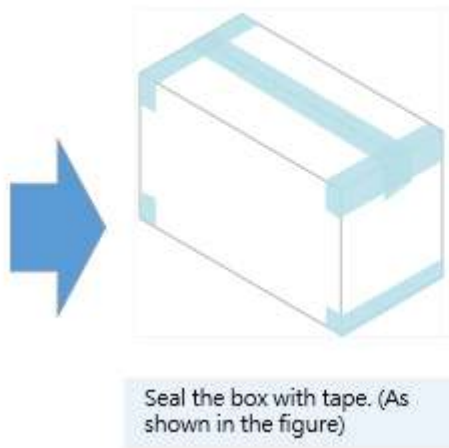
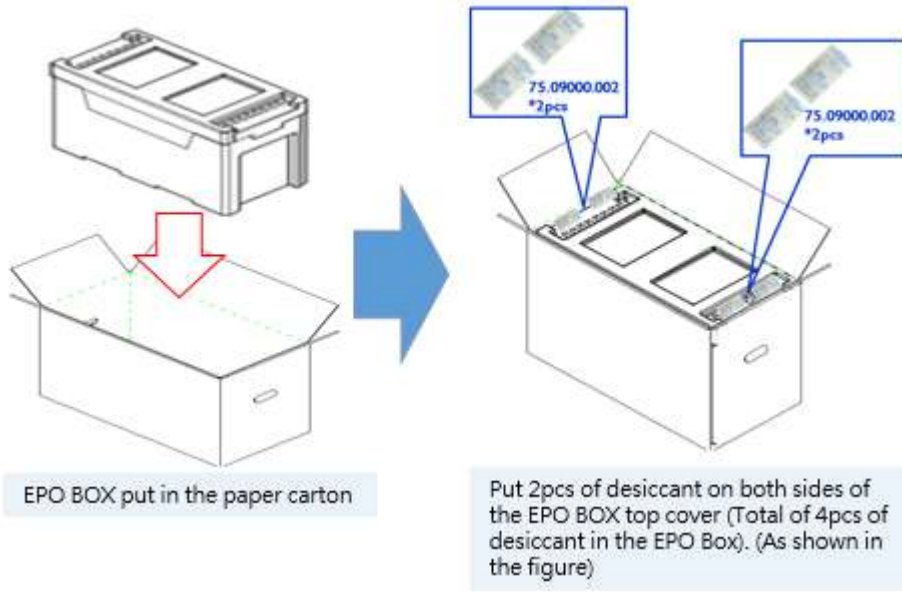

Single pallet packaging illustration

## 8.2 Pallet and shipment information

	Item	Specification			Remark
		Q'ty	Dimension	Weight(kg)	
1	Panel	1	623.7(H)mm x 362.1(V)mm x 12(D)mm	3233	
3	Box	1	756(L)mm x 371(W)mm x 467(H)mm	2.591	without Panel & cushion
4	Packing Box	10 pcs/Box	756(L)mm x 371(W)mm x 467(H)mm	34.92	with panel & cushion
5	Pallet	1	1150(L)mm x 840(W)mm x 132(H)mm	13.6	
6	Pallet after Packing	6 boxes/pallet	1150(L)mm x 840(W)mm x 1066(H)mm	223.12	

## 9 International Standard

### 9.1 Safety

- (1) UL 62368-1 : Audio/video, information and communication technology equipment – Part 1: Safety requirements
- (2) IEC 62368-1 : Audio/video, information and communication technology equipment –Part 1: Safety requirements
- (3) EN 62368-1 : Audio/video, information and communication technology equipment –Part 1: Safety requirements

### 9.2 EMC

- (1) ANSI C63.4 “Methods of Measurement of Radio-Noise Emissions from Low-Voltage Electrical and Electrical Equipment in the Range of 9kHz to 40GHz. “American National standards Institute(ANSI), 1992
- (2) C.I.S.P.R “Limits and Methods of Measurement of Radio Interface Characteristics of Information Technology Equipment.” International Special committee on Radio Interference.
- (3) EN 55022 “Limits and Methods of Measurement of Radio Interface Characteristics of Information Technology Equipment.” European Committee for Electrotechnical Standardization. (CENELEC), 1998

## 10 Precautions

Please pay attention to the followings when you use this TFT LCD module.

### 10.1 Mounting Precautions

- (1) You must mount a module using holes arranged in four corners or four sides.
- (2) You should consider the mounting structure so that uneven force (ex. twisted stress) is not applied to module. And the case on which a module is mounted should have sufficient strength so that external force is not transmitted directly to the module.
- (3) Please attach the surface transparent protective plate to the surface in order to protect the polarizer. Transparent protective plate should have sufficient strength in order to resist external force.
- (4) You should adopt radiation structure to satisfy the temperature specification.
- (5) Acetic acid type and chlorine type materials for the cover case are not desirable because the former generates corrosive gas of attacking the polarizer at high temperature and the latter cause circuit broken by electro-chemical reaction.
- (6) Do not touch, push or rub the exposed polarizer with glass, tweezers or anything harder than HB pencil lead. And please do not rub with dust clothes with chemical treatment. Do not touch the surface of polarizer for bare hand or greasy cloth. (Some cosmetics are detrimental to the polarizer.)
- (7) When the surface becomes dusty, please wipe gently with absorbent cotton or other soft materials like chamois soaks with petroleum benzene. Normal-hexane is recommended for cleaning the adhesives used to attach front/ rear polarizer. Do not use acetone, toluene and alcohol because they cause chemical damage to the polarizer.
- (8) Wipe off saliva or water drops as soon as possible. Their long time contact with polarizer causes deformations and color fading.
- (9) Do not open the case because inside circuits do not have sufficient strength.

### 10.2 Operating Precautions

- (1) The spike noise causes the mis-operation of circuits. It should be lower than following voltage:  $V=\pm 200\text{mV}$ (Over and under shoot voltage)
- (2) Response time depends on the temperature. (In lower temperature, it becomes longer.)
- (3) Brightness depends on the temperature. (In lower temperature, it may become lower.) And in lower temperature, response time (required time that brightness is stable after turned on) becomes longer.
- (4) Be careful for condensation at sudden temperature change. Condensation makes damage to polarizer or electrical contacted parts. And after fading condensation, smear or spot will occur.
- (5) When fixed patterns are displayed for a long time, remnant image is likely to occur.
- (6) Module has high frequency circuits. Sufficient suppression to the electromagnetic interference shall be done by system manufacturers. Grounding and shielding methods may be important to minimize the interface.
- (7) The conductive material and signal cables are kept away from LED driver inductor to prevent abnormal display, sound noise and temperature rising.

### 10.3 Operating Condition for Public Information Display

The device listed in the product specification is designed and manufactured for PID (Public Information Display) application. To optimize module's lifetime and function, below operating

usages are required.

- (1) Normal operating condition
  - A. Operating temperature: 0~50°C
  - B. Operating humidity: 5~90%
  - C. Display pattern: dynamic pattern (Real display).Note) Long-term static display would cause image sticking.
- (2) Operation usage to protect against image sticking due to long-term static display.
  - A. Suitable operating time: 16 hours a day or less.
  - B. Liquid Crystal refresh time is required. Cycling display between 5 minutes' information (static) display and 10 seconds' moving image.
  - C. Periodically change background and character (image) color.
  - D. Avoid combination of background and character with large different luminance.
- (3) Periodically adopt one of the following actions after long time display.
  - A. Running the screen saver (motion picture or black pattern)
  - B. Power off the system for a while
- (4) LCD system is required to place in well-ventilated environment. Adapting active cooling system is highly recommended.
- (5) Product reliability and functions are only guaranteed when the product is used under right operation usages. If product will be used in extreme conditions, such as high temperature/humidity, display stationary patterns, or long operation time etc..., it is strongly recommended to contact AUO for filed application engineering advice. Otherwise, its reliability and function may not be guaranteed. Extreme conditions are commonly found at airports, transit stations, banks, stock market and controlling systems.

#### 10.4 Electrostatic Discharge Control

Since a module is composed of electronic circuits, it is not strong to electrostatic discharge. Make certain that treatment persons are connected to ground through wristband etc. And don't touch interface pin directly.

#### 10.5 Precautions for Strong Light Exposure

- (1) Strong light exposure causes degradation of polarizer and color filter.
- (2) To keep display function well as a digital signage application, especially the component of TFT is very sensitive to sunlight, it is necessary to set up blocking device protecting panel from radiation of ambient environment.

#### 10.6 Storage

When storing modules as spares for a long time, the following precautions are necessary.

- (1) Store them in a dark place. Do not expose the module to sunlight or fluorescent light. Keep the temperature between 5°C and 35°C at normal humidity.
- (2) The polarizer surface should not come in contact with any other object. It is recommended that they be stored in the container in which they were shipped.
- (3) Storage condition is guaranteed under packing conditions.
- (4) The phase transition of Liquid Crystal in the condition of the low or high storage temperature will be recovered when the LCD module returns to the normal condition.

#### 10.7 Handling Precautions for Protection Film

- (1) The protection film is attached to the bezel with a small masking tape. When the protection film is peeled off, static electricity is generated between the film and polarizer. This should be peeled off slowly and carefully by people who are electrically grounded and with well ion-blown equipment or in such a condition, etc.
- (2) When the module with protection film attached is stored for a long time, sometimes there remains a very small amount of glue still on the bezel after the protection film is peeled off.
- (3) You can remove the glue easily. When the glue remains on the bezel or its vestige is recognized, please wipe them off with absorbent cotton waste or other soft material like chamois soaked with normal-hexane.

**10.8 Dust Resistance**

- (1) ADP module dust tests are conducted with marked areas (e.g., holes and slits around the front bezel and back cover) sealed, to comply with JIS D0207 (see Figure 1).
- (2) To prevent particles from entering the module, please ensure the set has all the highlighted areas (holes and slits) adequately sealed or covered by set mechanism.
- (3) ADP’s testing procedure cannot replicate all real world operation scenarios. It is up to the module user to apply the most appropriate dust resistance solution for its particular application.

