



Product Specification

G215HVN01.3

AU OPTRONICS CORPORATION

Preliminary Specification

Final Specification

Module	21.5" Color TFT-LCD
Model Name	G215HVN01.3

Customer	Date
_____	_____
Checked & Approved by	
_____	_____
Note: This Specification is subject to change without notice.	

Approved by	Date
<i>Flossie Chuang</i>	<i>2021/10/01</i>
Prepared by	
<i>Roxanne Lin</i>	<i>2021/10/01</i>
General Display Business Division / AU Optronics corporation	



Contents

- 1. Operating Precautions 4**
- 2. General Description 5**
 - 2.1 Display Characteristics5
 - 2.2 Optical Characteristics6
- 3. Functional Block Diagram 10**
- 4. Absolute Maximum Ratings 11**
 - 4.1 TFT LCD Module 11
 - 4.2 Backlight Unit..... 11
- 5. Electrical Characteristics 13**
 - 5.1 TFT LCD Module 13
 - 5.2 Backlight Unit..... 15
- 6. Signal Characteristic 20**
 - 6.1 Pixel Format Image20
 - 6.2 Signal Description21
 - 6.3 The Input Data Format23
 - 6.4 Interface Timing.....24
 - 6.5 Power ON/OFF Sequence.....25
- 7. Connector & Pin Assignment..... 27**
 - 7.1 TFT LCD Module: LVDS Connector.....27
 - 7.2 Backlight Unit: LED Connector28
- 8. Reliability Test 29**
- 9. Mechanical Characteristics 30**
- 10. Label and Packaging 32**
 - 10.1 Shipping Label (on the rear side of TFT-LCD display).....32
 - 10.2 Carton Package32
- 11. Safety 35**
 - 11.1 Sharp Edge Requirements.....35
 - 11.2 Materials35
 - 11.3 Capacitors35
 - 11.4 National Test Lab Requirement35

Record of Revision

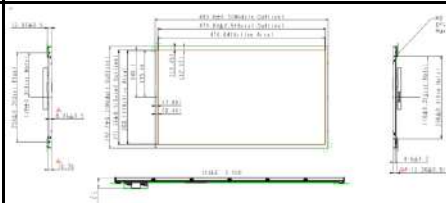
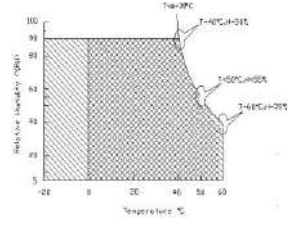
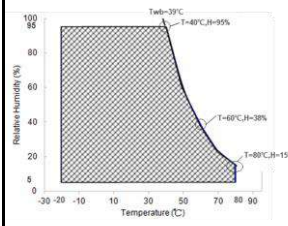
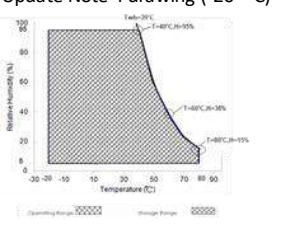
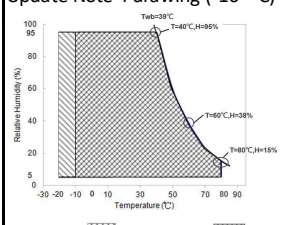
Version and Date	Page	Old description	New Description	Remark																																																								
0.1 2020/05/07	All	First Edition	All																																																									
0.2 2020/11/13	4	2.1 Display characteristics <table border="1"> <tr> <td>Power Consumption</td> <td>[Watt]</td> <td>42.4 W (Typ. Cell 3.5 + LED 23.2)</td> </tr> <tr> <td>Weight</td> <td>[g]</td> <td>1,850 (+/- 185 g)</td> </tr> <tr> <td>Product Size</td> <td>[mm]</td> <td>495.6(W) × 292.2(H) × 20.5(D)</td> </tr> </table>	Power Consumption	[Watt]	42.4 W (Typ. Cell 3.5 + LED 23.2)	Weight	[g]	1,850 (+/- 185 g)	Product Size	[mm]	495.6(W) × 292.2(H) × 20.5(D)	<table border="1"> <tr> <td>Power Consumption</td> <td>[Watt]</td> <td>28.7 W (Typ. Cell 3.5 + LED 23.2)</td> </tr> <tr> <td>Physical Size</td> <td>[mm]</td> <td>495.6(W) × 292.2(H) × 24.05(D)</td> </tr> </table>	Power Consumption	[Watt]	28.7 W (Typ. Cell 3.5 + LED 23.2)	Physical Size	[mm]	495.6(W) × 292.2(H) × 24.05(D)																																										
Power Consumption	[Watt]	42.4 W (Typ. Cell 3.5 + LED 23.2)																																																										
Weight	[g]	1,850 (+/- 185 g)																																																										
Product Size	[mm]	495.6(W) × 292.2(H) × 20.5(D)																																																										
Power Consumption	[Watt]	28.7 W (Typ. Cell 3.5 + LED 23.2)																																																										
Physical Size	[mm]	495.6(W) × 292.2(H) × 24.05(D)																																																										
0.2 2020/11/13	15	5.2.1 LED <table border="1"> <tr> <th>Symbol</th> <th>Parameter</th> <th>Min.</th> <th>Typ.</th> <th>Max.</th> <th>Unit</th> <th>Remark</th> </tr> <tr> <td>LED</td> <td>Input Voltage</td> <td>2.61</td> <td>2.9</td> <td>3.10</td> <td>Volt</td> <td></td> </tr> <tr> <td>PLD</td> <td>Power Consumption</td> <td>~</td> <td>23.2</td> <td>26.4</td> <td>Watt</td> <td></td> </tr> <tr> <td>I_f</td> <td>LED Forward Current</td> <td>~</td> <td>50</td> <td>~</td> <td>mA</td> <td>Ta = 25°C, Note 1</td> </tr> </table>	Symbol	Parameter	Min.	Typ.	Max.	Unit	Remark	LED	Input Voltage	2.61	2.9	3.10	Volt		PLD	Power Consumption	~	23.2	26.4	Watt		I _f	LED Forward Current	~	50	~	mA	Ta = 25°C, Note 1	<table border="1"> <tr> <th>Symbol</th> <th>Parameter</th> <th>Min.</th> <th>Typ.</th> <th>Max.</th> <th>Unit</th> <th>Remark</th> </tr> <tr> <td>LED</td> <td>Input Voltage</td> <td>2.61</td> <td>2.9</td> <td>3.10</td> <td>Volt</td> <td></td> </tr> <tr> <td>PLD</td> <td>Power Consumption</td> <td>~</td> <td>23.2</td> <td>26.4</td> <td>Watt</td> <td></td> </tr> <tr> <td>I_f</td> <td>LED Forward Current</td> <td>~</td> <td>50</td> <td>~</td> <td>mA</td> <td>Ta = 25°C, Note 1</td> </tr> </table>	Symbol	Parameter	Min.	Typ.	Max.	Unit	Remark	LED	Input Voltage	2.61	2.9	3.10	Volt		PLD	Power Consumption	~	23.2	26.4	Watt		I _f	LED Forward Current	~	50	~	mA	Ta = 25°C, Note 1	
Symbol	Parameter	Min.	Typ.	Max.	Unit	Remark																																																						
LED	Input Voltage	2.61	2.9	3.10	Volt																																																							
PLD	Power Consumption	~	23.2	26.4	Watt																																																							
I _f	LED Forward Current	~	50	~	mA	Ta = 25°C, Note 1																																																						
Symbol	Parameter	Min.	Typ.	Max.	Unit	Remark																																																						
LED	Input Voltage	2.61	2.9	3.10	Volt																																																							
PLD	Power Consumption	~	23.2	26.4	Watt																																																							
I _f	LED Forward Current	~	50	~	mA	Ta = 25°C, Note 1																																																						
0.2 2020/11/13	29	9.0 Mechanical Characteristics 																																																										
0.3 2020/12/03	7	2.2 Optical Characteristics Luminance Uniformity: 70%(min.)/75%(typ.)	2.2 Optical Characteristics Luminance Uniformity: 75%(min.)/80%(typ.)																																																									
0.4 2021/04/19	5	2.1 Display Characteristics Weight: 1850(+/-185)g	2.1 Display Characteristics Weight: 1630(+/-163)g																																																									
0.5 2021/07/09	12	Note 4: Operation Temperature + 60°C is defined as panel surface temperature. 	Note 4: Operation Temperature + 80°C is defined as panel surface temperature. 																																																									
1.0 2021/10/01	5	2.1 Panel Characteristics Temperature Range Operation: -20 ° C~80 ° C	2.1 Panel Characteristics Temperature Range Operation: -10° C~80° C																																																									
1.0 2021/10/01	11	4.3 Absolute Ratings of Environment <table border="1"> <tr> <th>Item</th> <th>Symbol</th> <th>Min.</th> <th>Max.</th> <th>Unit</th> </tr> <tr> <td>Operating</td> <td>TOP</td> <td>-20</td> <td>+60</td> <td>[°C]</td> </tr> </table>	Item	Symbol	Min.	Max.	Unit	Operating	TOP	-20	+60	[°C]	4.3 Absolute Ratings of Environment <table border="1"> <tr> <th>Item</th> <th>Symbol</th> <th>Min.</th> <th>Max.</th> <th>Unit</th> </tr> <tr> <td>Operating Temperature</td> <td>TOP</td> <td>-10</td> <td>+80</td> <td>[°C]</td> </tr> </table>	Item	Symbol	Min.	Max.	Unit	Operating Temperature	TOP	-10	+80	[°C]																																					
Item	Symbol	Min.	Max.	Unit																																																								
Operating	TOP	-20	+60	[°C]																																																								
Item	Symbol	Min.	Max.	Unit																																																								
Operating Temperature	TOP	-10	+80	[°C]																																																								
1.0 2021/10/01	12	Update Note 4 drawing (-20 ° C) 	Update Note 4 drawing (-10 ° C) 																																																									
1.0 2021/10/01	27	8. Reliability Test <table border="1"> <tr> <td>Low Temperature Operation (LTO)</td> <td>Ta= 0°C, 300hours</td> </tr> </table>	Low Temperature Operation (LTO)	Ta= 0°C, 300hours	8. Reliability Test <table border="1"> <tr> <td>Low Temperature Operation (LTO)</td> <td>Ta= -10°C, 300hours</td> </tr> </table>	Low Temperature Operation (LTO)	Ta= -10°C, 300hours																																																					
Low Temperature Operation (LTO)	Ta= 0°C, 300hours																																																											
Low Temperature Operation (LTO)	Ta= -10°C, 300hours																																																											

1. Operating Precautions

- 1) Since front polarizer is easily damaged, pay attention not to scratch it.
- 2) Be sure to turn off power supply when inserting or disconnecting from input connector.
- 3) Wipe off water drop immediately. Long contact with water may cause discoloration or spots.
- 4) When the panel surface is soiled, wipe it with absorbent cotton or other soft cloth.
- 5) Since the panel is made of glass, it may break or crack if dropped or bumped on hard surface.
- 6) Since CMOS LSI is used in this module, take care of static electricity and insure human earth when handling.
- 7) Do not open or modify the Module Assembly.
- 8) In case if a Module has to be put back into the packing container slot after once it was taken out from the container, take it easily, or the TFT Module may be damaged.
- 9) At the insertion or removal of the Signal Interface Connector, be sure not to rotate nor tilt the Interface Connector of the TFT Module.
- 10) After installation of the TFT Module into an enclosure, do not twist nor bend the TFT Module even momentary. At designing the enclosure, it should be taken into consideration that no bending/twisting forces are applied to the TFT Module from outside. Otherwise the TFT Module may be damaged.
- 11) Small amount of materials having no flammability grade is used in the LCD module. The LCD module should be supplied by power complied with requirements of Limited Power Source (IEC60950 or UL1950), or be applied exemption.
- 12) Severe temperature condition may result in different luminance, response time and LED life time.
- 13) The data on this specification sheet is applicable when LCD module is placed in landscape position.
- 14) Continuous displaying fixed pattern may induce image sticking. It is recommended to use screen saver or shuffle content periodically if fixed pattern is displayed on the screen.

2. General Description

This specification applies to the 21.5 inch-wide Color TFT-LCD Module G215HVN01.3. The display supports the Full HD - 1920(H) x 1080(V) screen format and 16.7M colors (RGB 8-bits data). All input signals are dual channel LVDS interface.

LED driver board is included. G215HVN01.3 is designed for industrial display applications.

2.1 Display Characteristics

The following items are characteristics summary on the table under 25°C condition

ITEMS	Unit	SPECIFICATIONS
Screen Diagonal	[inch]	21.5
Active Area	[mm]	476.64 (H) x 268.11 (V)
Pixels H x V		1920(x3) x 1080
Pixel Pitch	[um]	248.25 (per one triad) x248.25
Pixel Arrangement		R.G.B. Vertical Stripe
Display Mode		VA Mode, Normally Black
White Luminance (Center)	[cd/m ²]	1000 (Typ.)
Contrast Ratio		5000 (Typ.)
Optical Response Time	[msec]	25 ms (Typ., on/off)
Nominal Input Voltage	[Volt]	+5.0 V
Backlight Input Voltage	[Volt]	+3 V
Power Consumption	[Watt]	26.7 W (Typ. Cell 3.5 + LED 23.2)
Weight	[Grams]	1,630 (± 163 g)
Physical Size	[mm]	495.6(W) x 292.2(H) x 24.05(D)
Electrical Interface		Dual channel LVDS
Support Color		16.7M colors (RGB 8 bits)
Surface Treatment		Anti-Glare, 3H
Temperature Range		
Operating	[°C]	-10 to +80
Storage (Non-Operating)	[°C]	-20 to +80
RoHS Compliance		RoHS Compliance
TCO Compliance		TCO 5.1 Compliance

2.2 Optical Characteristics

The optical characteristics are measured under stable conditions at 25°C :

Item	Unit	Conditions	Min.	Typ.	Max.	Note
Viewing Angle	[degree]	Horizontal (Right) CR = 10 (Left)	75 75	89 89	- -	1, 2
	[degree]	Vertical (Upper) CR = 10 (Lower)	75 75	89 89	- -	
Contrast ratio		Normal Direction	3000	5000	-	3
Response Time	[msec]	Raising Time (T _{rR})	-	20	25	4
		Falling Time (T _{rF})	-	5	10	
		Raising + Falling	-	25	35	
Color / Chromaticity Coordinates (CIE)		Red x	0.589	0.639	0.689	5
		Red y	0.284	0.334	0.384	
		Green x	0.274	0.324	0.374	
		Green y	0.563	0.613	0.663	
		Blue x	0.103	0.153	0.203	
		Blue y	0.012	0.062	0.112	
Color Coordinates (CIE) White		White x	0.263	0.313	0.363	6
		White y	0.279	0.329	0.379	
Central Luminance	[cd/m ²]		800	1000	-	6
Luminance Uniformity	[%]		75	80	-	7
Crosstalk (in 60Hz)	[%]				1.5	8
Flicker	dB				-20	9

Note 1: Measurement method

Before measuring, the LCD module should be turn on 30 minutes at room temperature. In order to stabilize the luminance, the measurement should be executed after lighting Backlight for 30 minutes in a stable, windless and dark room.

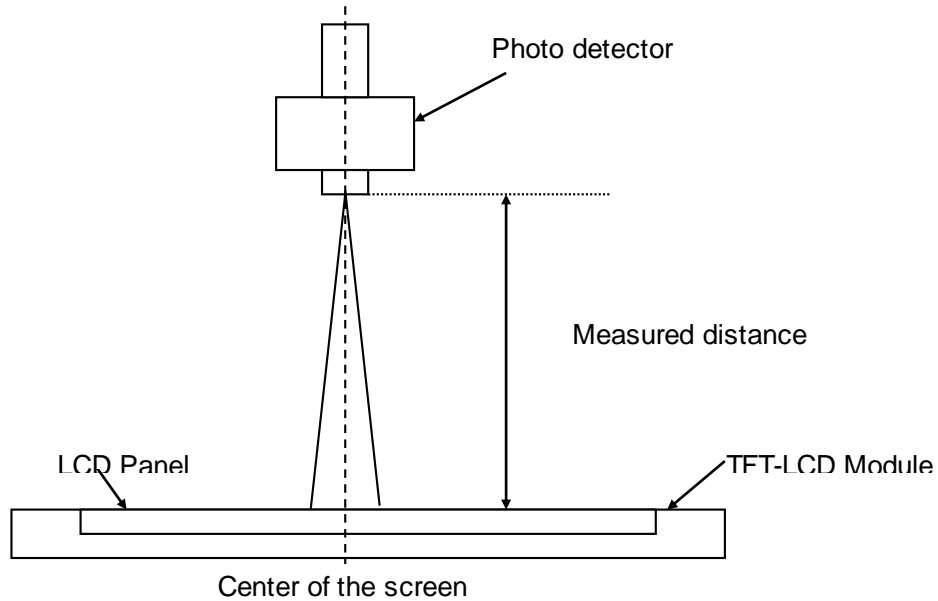

Note 2: Definition of viewing angle measured by ELDIM (EZContrast 88)

Viewing angle is the measurement of contrast ratio ≥ 10 , at the screen center, over a 180° horizontal and 180° vertical range (off-normal viewing angles). The 180° viewing angle range is broken down as follows; 90° (θ) horizontal left and right and 90° (Φ) vertical, high (up) and low (down). The measurement direction is typically perpendicular to the display surface with the screen rotated about its center to develop the desired measurement viewing angle.

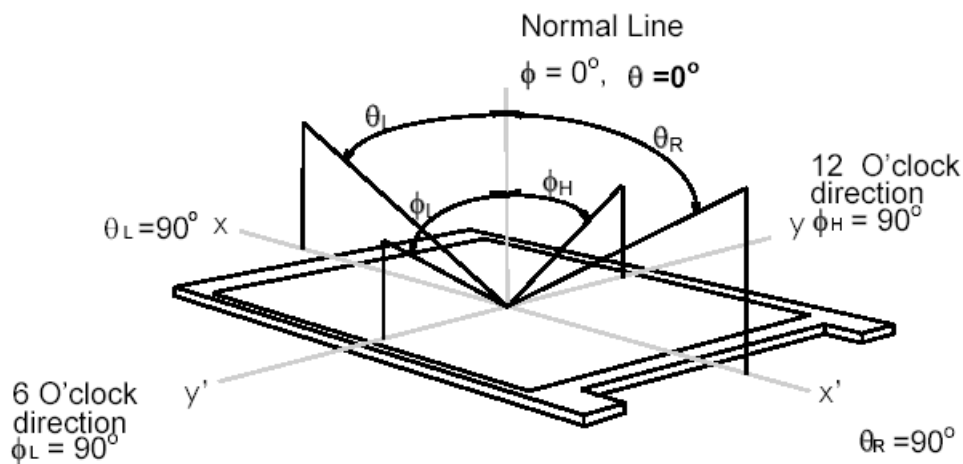

Note 3: Contrast ratio is measured by TOPCON SR-3

Note 4: Definition of Response time measured by Westar TRD-100A

The output signals of photo detector are measured when the input signals are changed from “Full Black” to “Full White” (rising time, T_{rR}), and from “Full White” to “Full Black” (falling time, T_{rF}), respectively. The response time is interval between the 10% and 90% (1 frame at 60 Hz) of amplitudes.

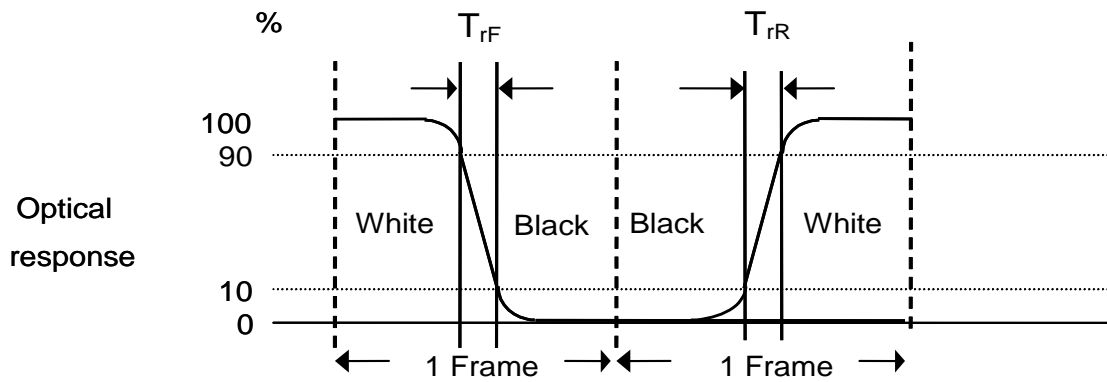

Note 5: Color chromaticity and coordinates (CIE) is measured by TOPCON SR-3

Note 6: Central luminance is measured by TOPCON SR-3

Note 7: Luminance uniformity of these 9 points is defined as below and measured by TOPCON SR-3

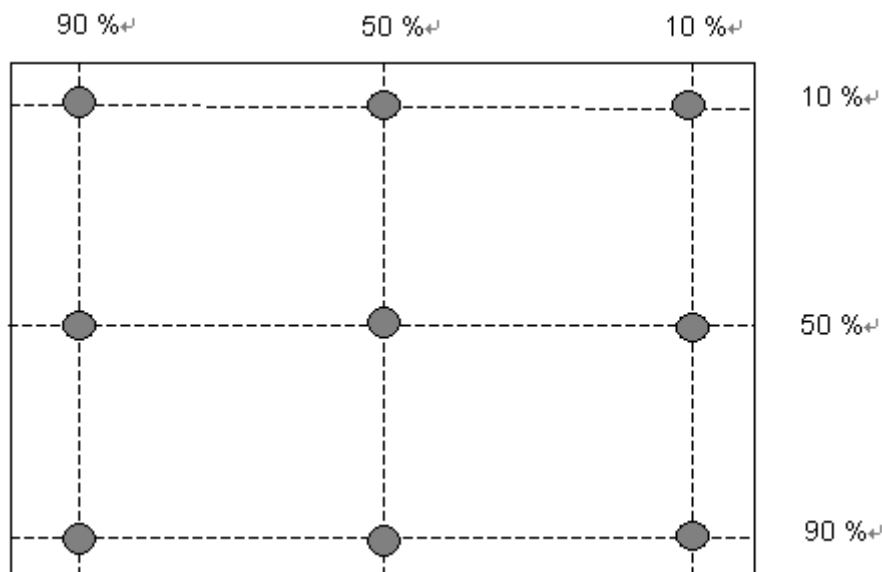

$$\text{Uniformity} = \frac{\text{Minimum Luminance in 9 points (1-9)}}{\text{Maximum Luminance in 9 Points (1-9)}}$$

Note 8: Crosstalk is defined as below and measured by TOPCON SR-3

$$CT = |Y_B - Y_A| / Y_A \times 100 (\%)$$

Where

Y_A = Luminance of measured location without gray level 0 pattern (cd/m²)

Y_B = Luminance of measured location with gray level 0 pattern (cd/m²)

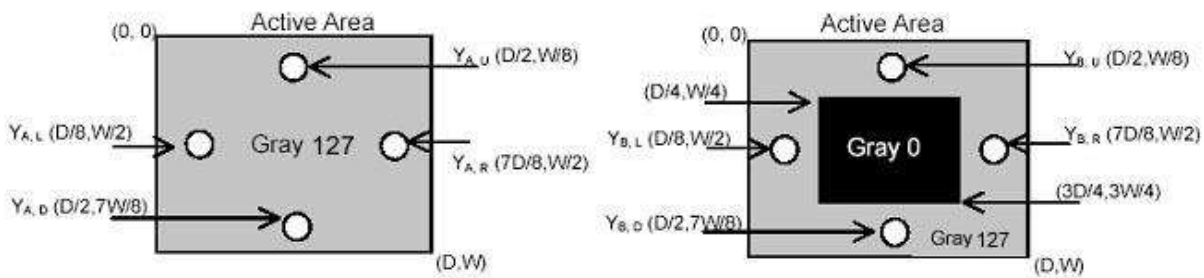

Note 9: Test Pattern: Subchecker Pattern measured by TOPCON SR-3

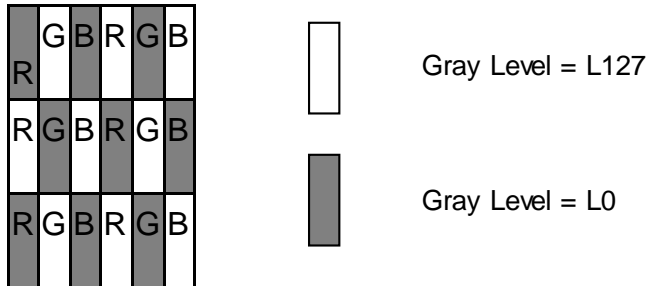

Method: Record dB value with TRD-100

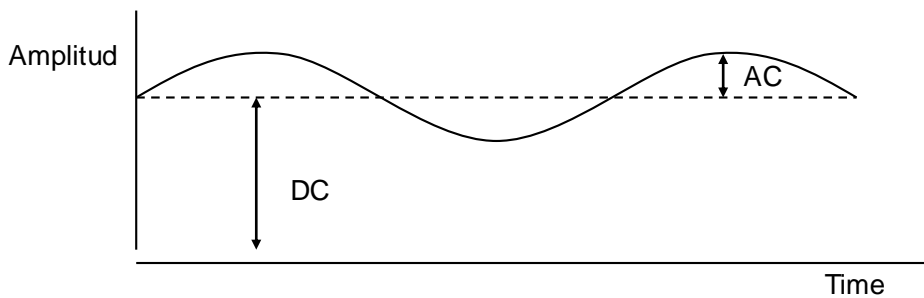

$$\text{Flicker (dB)} = 20 \log \frac{\text{AC Level (at 30 Hz)}}{\text{DC Level}}$$

3. Functional Block Diagram

The following diagram shows the functional block of this model.

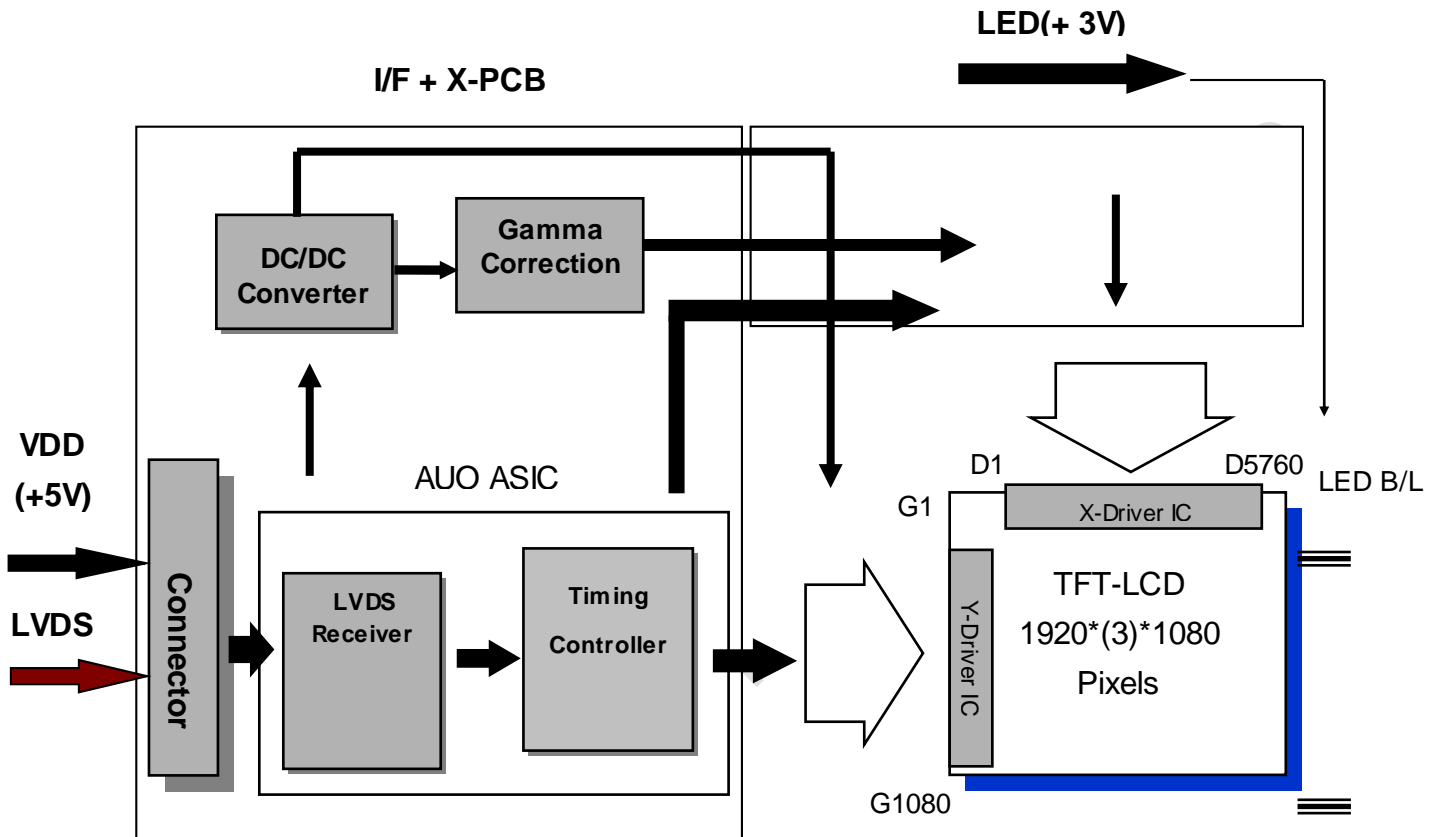

LVDS Connector: JAE (FI-XB30SRL-HF11) or equivalent.

LED Connector: CviLux (CI1406M1HRL-NH) or equivalent.

4. Absolute Maximum Ratings

4.1 TFT LCD Module

Item	Symbol	Min	Max	Unit	Conditions
Logic/LCD Drive Voltage	VDD	0	5.5	[Volt]	Note 1,2

4.2 Backlight Unit

Item	Symbol	Min	Max	Unit	Conditions
LED Input Voltage	LED	3.0	3.3	[Volt]	Note 1,2

4.3 Absolute Ratings of Environment



Item	Symbol	Min.	Max.	Unit	Conditions
Operating	TOP	-10	+80	[°C]	Note 3 & 4
Operation Humidity	HOP	5	90	[%RH]	
Storage Temperature	TST	-20	+80	[°C]	
Storage Humidity	HST	5	90	[%RH]	

Note 1: With in Ta (25°C)

Note 2: Permanent damage to the device may occur if exceeding maximum values

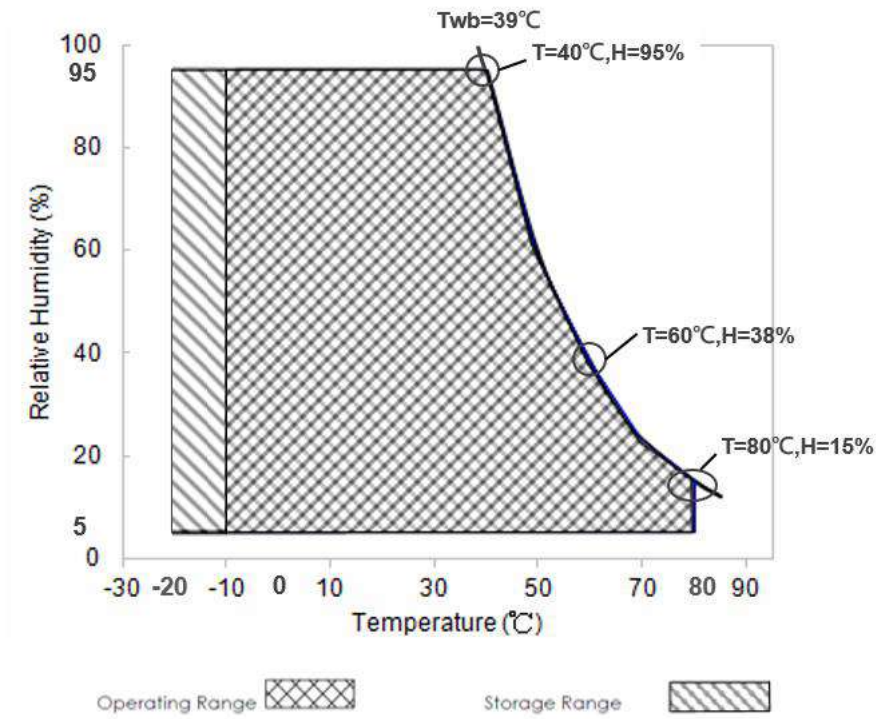
Note 3: For quality performance, please refer to AUO IIS (Incoming Inspection Standard).



Operating Range  Storage Range  + 

Note 4: Operation Temperature + 80°C is defined as panel surface temperature.

5. Electrical Characteristics

5.1 TFT LCD Module

5.1.1 Power Specification

Symbol	Parameter	Min	Typ	Max	Unit	Conditions
VDD	Logic/LCD Drive Voltage	4.5	5.0	5.5	[Volt]	+/-10%
IDD	Input Current	-	0.7	0.8	[A]	VDD= 5.0V, All white pattern, At 60Hz
		-	0.81	0.89	[A]	VDD= 5.0V, All white pattern At 75Hz,
PDD	VDD Power	-	3.5	4.4	[Watt]	VDD= 5.0V, All white pattern, At 60Hz
		-	4.05	4.9	[Watt]	VDD= 5.0V, All white pattern At 75Hz,
IRush	Inrush Current	-	-	3	[A]	Note 1
VDDrp	Allowable Logic/LCD Drive Ripple Voltage	-	-	500	[mV] p-p	VDD= 5.0V, All white Pattern At 75Hz

Note 1: Measurement conditions:

The duration of rising time of power input is 470us.

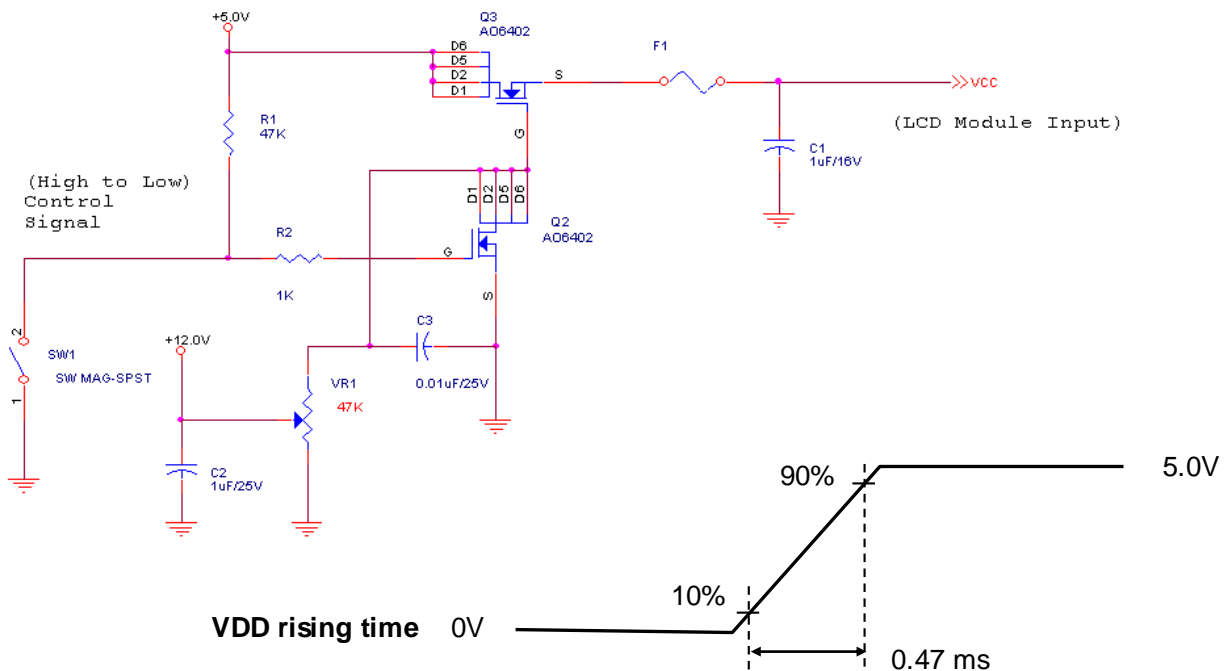

5.1.2 Signal Electrical Characteristics

Input signals shall be low or Hi-Z state when VDD is off. Please refer to specifications of SN75LVDS82DGG (Texas Instruments) in detail.

Symbol	Parameter	Min	Typ	Max	Units	Condition
V_{TH}	Differential Input High Threshold	-	-	+100	[mV]	$V_{CM} = 1.2V$, <i>Note 1</i>
V_{TL}	Differential Input Low Threshold	-100	-	-	[mV]	$V_{CM} = 1.2V$ <i>Note 1</i>
$ V_{ID} $	Input Differential Voltage	100	-	600	[mV]	<i>Note 1</i>
V_{CM}	Differential Input Common Mode Voltage	+1.0	+1.2	+1.5	[V]	$V_{TH} - V_{TL} = 200MV$ (max) <i>Note 1</i>

Note 1: LVDS Signal Waveform

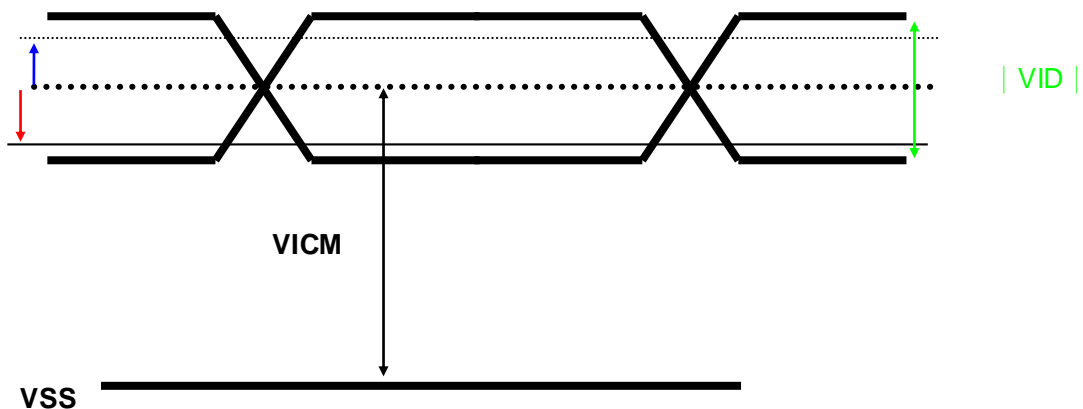

5.2 Backlight Unit

5.2.1 LED

Following characteristics are measured under stable condition at 25°C (Room Temperature).

Symbol	Parameter	Min	Typ	Max	Unit	Remark
LED	Input Voltage	2.61	2.9	3.19	Volt	
PLED	Power Consumption	-	23.2	26.4	Watt	
I _F	LED Forward Current	-	50	-	mA	Ta = 25°C, Note1
LTLED	LED Life Time (Brightness decay)	50,000	-	-	Hrs	Note 4

Note 1: Ta means ambient temperature.

Note 2: If module is driven by high current or at high ambient temperature & humidity condition. The operating life will be reduced.

Note 3: LED light bar structure: (2 Light bar x 4 strings x 20pcs / string =160pcs LED)

Note 4: Definition of life time: Brightness becomes to 50% of its original value. The minimum life time of LED unit is on the condition of I_F = 50 mA and 25°C (Room Temperature).

5.2.2 Input of BLU (with driver)

(Darwin P/N : 55.21G0W.DE0 DARFON Model : V351-405)

Item	Symbol	Min.	Typ.	Max.	Unit	Note
Driving Type	<input type="checkbox"/> Analog <input checked="" type="checkbox"/> PWM 180 Hz					
Input voltage	V _{in}	10.8	12	13.2	V[dc]	
Input current	I _{in}	-	3.42	-	A[dc]	
Power consumption	P _{BL}		41.04		Watt	
Test conditions	Environment	T=25±3°C H=65±20%				
	Method	See attachment " test detail-1 (a)"				

5.2.3 Pin assignment: Define by Light-bar Drawing:

LED light-bar Connector Manufacturer	Cvilux
--------------------------------------	--------

LB-U

PIN ASSIGNMENT (CONNECTOR)	
PIN 1	-
PIN 2	-
PIN 3	+
PIN 4	+
PIN 5	-
PIN 6	-

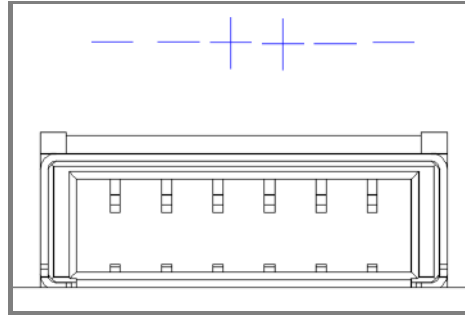

LB-D

PIN ASSIGNMENT (CONNECTOR)	
PIN 1	-
PIN 2	-
PIN 3	+
PIN 4	+
PIN 5	-
PIN 6	-

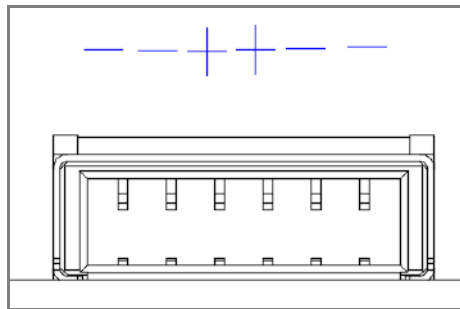

5.2.4 Pin assignment: Define by Driver Board Drawing:

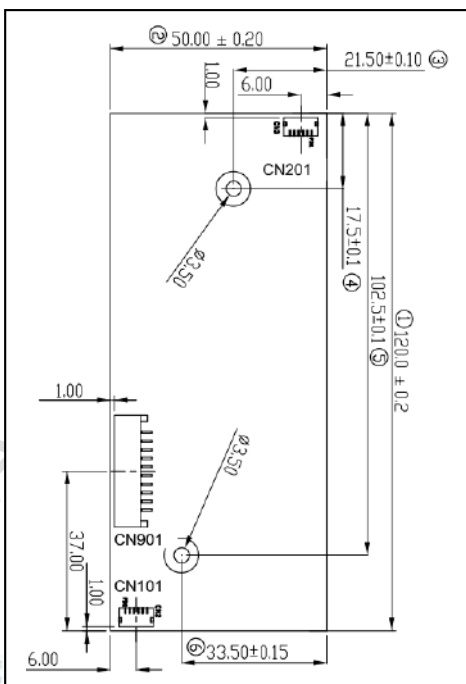

Input connector (CN901)

TYPE:CI0110M1HRO-NH(CVILUX) or compatible

Pin No.	Signal Name	Feature
1	VCC	Supply Voltage 12V
2	VCC	Supply Voltage 12V
3	VCC	Supply Voltage 12V
4	VCC	Supply Voltage 12V
5	GND	Ground
6	GND	Ground
7	GND	Ground
8	GND	Ground
9	BLON	BL ON/OFF
10	E_PWM	External PWM Control (HW mode)

Output connector (CN101 ,CN201)

TYPE:3707K-X6N-00X(ENTERY) or compatible

Pin No	Symbol		Description
1	1-1 Cathode	O	Cathode of LB-D PIN1
2	1-2 Cathode	O	Cathode of LB-D PIN2
3	1-1 Anode	O	Anode of LB-D PIN3
4	1-2 Ahode	O	Anode of LB-D PIN4
5	1-3 Cathode	O	Cathode of LB-D PIN5
6	1-4 Cathode	O	Cathode of LB-D PIN6

Pin No	Symbol	I/O	Description
1	2-1 Cathode	O	Cathode of LB-U PIN1
2	2-2 Cathode	O	Cathode of LB-U PIN2
3	2-1 Anode	O	Anode of LB-U PIN3
4	2-2 Ahode	O	Anode of LB-U PIN4

5	2-3 Cathode	O	Cathode of LB-U PIN5
6	2-4 Cathode	O	Cathode of LB-U PIN6

5.2.5 Interface Characteristics

No	ITEM	SYMBOL	CONDITION TEST	MIN	TYPE	MAX	UNIT	NOTE(11-13)	
1	On/Off Control Voltage	ON	—	2.0	—	5	V		
		OFF	—	0	—	0.8	V		
2	Error Signal	ERR	—	—	—	—	—	Normal: GND Abnormal: Open collector (Note 12)	
3	External PWM Control Voltage	H	VSEL = H	2.0	—	3.3	V	ON Duration	(Note 13)
		L	VSEL = H	0	—	0.8	V	OFF Duration	
4	Control Signal Rising Time	Tr	—	—	—	100	ms	See Fig.1	
5	Control Signal Falling Time	Tf	—	—	—	100	ms		
6	VBL Rising Time	Tr1	—	20	—	—	ms		
7	VBL Falling Time	Tf1	—	20	—	—	ms		
8	PWM Signal Rising Time	TPWMR	—	—	—	50	us		
9	PWM Signal Falling Time	TPWMF	—	—	—	50	us		
10	Input impedance	RIN	—	300	—	—	KΩ	VBLON / VEPWM	
11	BLON Delay Time	Ton	—	300	—	500	mS		
12	BLON Off Time	Toff	—	300	—	500	ms		
13	External Dimming Control Frequency	FEPWM	—	90	180	240	Hz		
14	External Dimming Control Duty	EPWM	—	0	—	100	%		

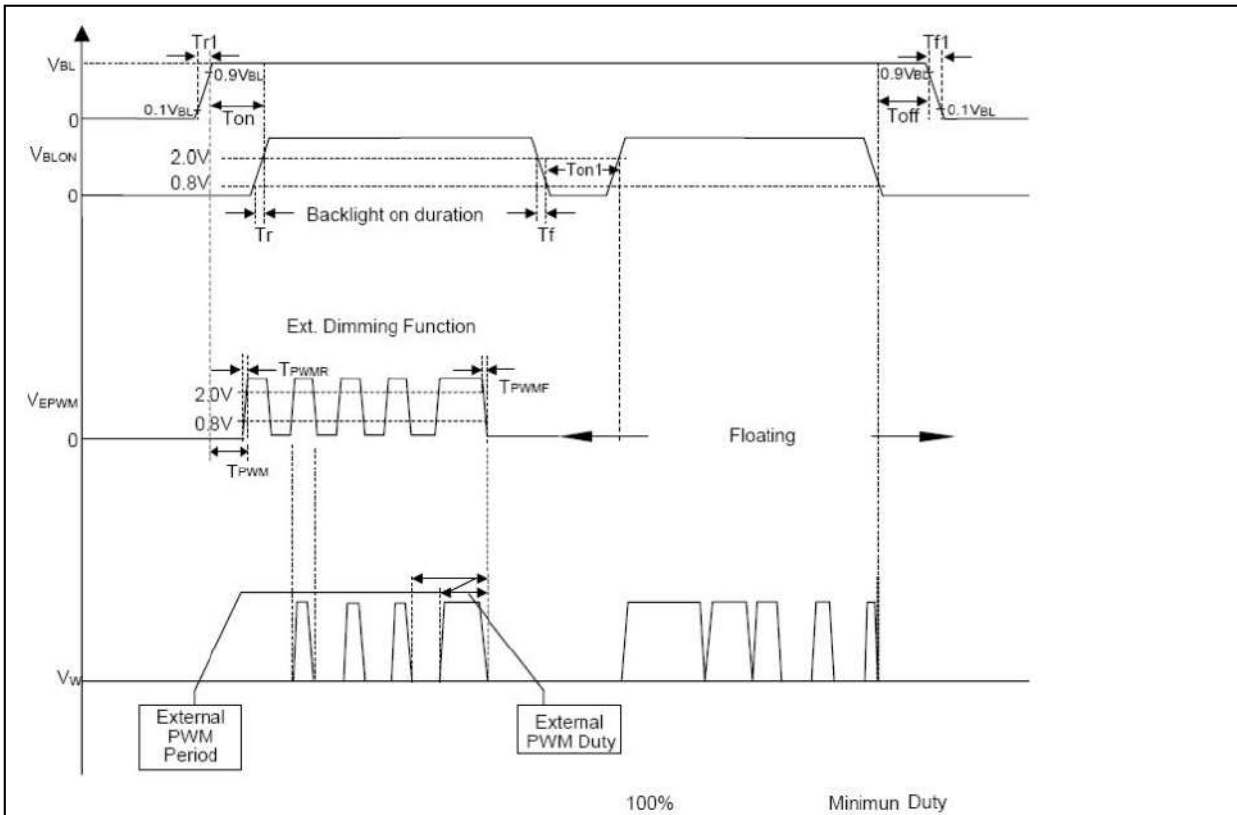

Note 9: Even if control signal over range in any conditions, there must no smell, smoke, and fire cause by any failure on Converter PCB or components.

Note 10: With any kind of power sequence and timing, the Converter must not damage or malfunction.

Note 11: The Converter interface please refers to Fig.1.

Note 12: When converter protective function is triggered, DET will output open collector status.

Note 13: The E_PWM interface circuit must pull high when the function is floating.

5.2.6 Protection Characteristics

NO	ITEM	TEST CONDITION	RESPONSE OF SUBJECT	NOTE
1	Output Short Circuit Protection(SCP)	Each Output	Shutdown or (fuse open)	
2	Output Over Voltage Protection(OVP)	70 Vmax	Shutdown or (Latch)	
3	Input Over Voltage Protection (IOP)	-	Shutdown or (Auto-reset)	
4	Output Connector Open	Each Connceptor	No damage or azardous condition will occur	

6.2 Signal Description

The module using a pair of LVDS receiver SN75LVDS82(Texas Instruments) or compatible. LVDS is a differential signal technology for LCD interface and high speed data transfer device. Transmitter shall be SN75LVDS83(negative edge sampling) or compatible. The first LVDS port(RxOxxx) transmits odd pixels while the second LVDS port(RxExxx) transmits even pixels.

PIN #	SIGNAL NAME	DESCRIPTION
1	RXinO0-	Negative LVDS differential data input (Odd data)
2	RXinO0+	Positive LVDS differential data input (Odd data)
3	RXinO1-	Negative LVDS differential data input (Odd data)
4	RXinO1+	Positive LVDS differential data input (Odd data)
5	RXinO2-	Negative LVDS differential data input (Odd data, H-Sync, V-Sync, DSPTMG)
6	RXinO2+	Positive LVDS differential data input (Odd data, H-Sync, V-Sync, DSPTMG)
7	GND	Power Ground
8	RxOCLKIN-	Negative LVDS differential clock input (Odd clock)
9	RxOCLKIN+	Positive LVDS differential clock input (Odd clock)
10	RXinO3-	Negative LVDS differential data input (Odd data)
11	RXinO3+	Positive LVDS differential data input (Odd data)
12	RXinE0-	Negative LVDS differential data input (Even data)
13	RXinE0+	Positive LVDS differential data input (Even data)
14	GND	Power Ground
15	RXinE1-	Negative LVDS differential data input (Even data)
16	RXinE1+	Positive LVDS differential data input (Even data)
17	GND	Power Ground
18	RXinE2-	Negative LVDS differential data input (Even data)
19	RXinE2+	Positive LVDS differential data input (Even data)
20	RxECLKIN-	Negative LVDS differential clock input (Even clock)
21	RxECLKIN+	Positive LVDS differential clock input (Even clock)
22	RXinE3-	Negative LVDS differential data input (Even data)
23	RXinE3+	Positive LVDS differential data input (Even data)
24	GND	Power Ground
25	NC	No connection (for AUO test only. Do not connect)
26	NC	No connection (for AUO test only. Do not connect)
27	NC	No connection (for AUO test only. Do not connect)
28	VDD	Power +5V



29	VDD	Power +5V
30	VDD	Power +5V

6.3 The Input Data Format

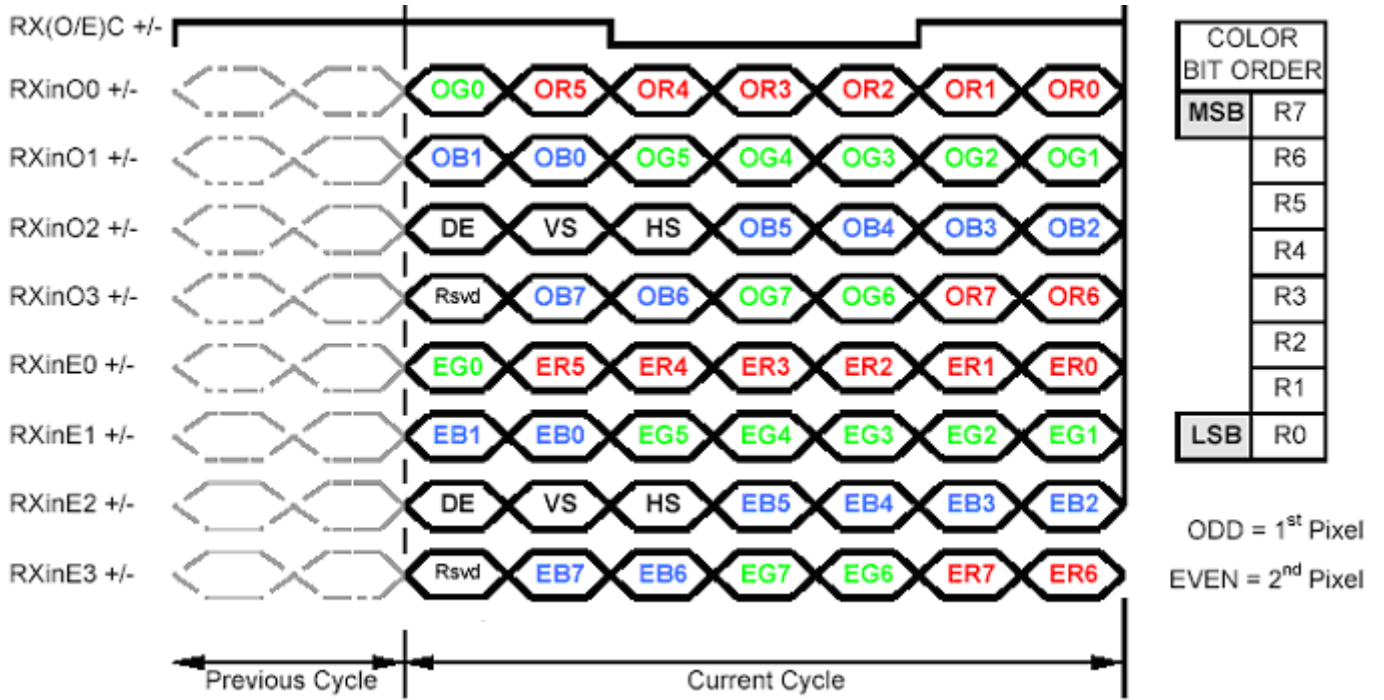

Note1: 8-bits signal input.

Note2: L:NS alike H:Thine alike

6.4 Interface Timing

6.4.1 Timing Characteristics

Signal	Item	Symbol	Min	Typ	Max	Unit
Clock	Frequency	$1/ T_{\text{Clock}}$	40	72	83	MHz
Frame Rate	Frequency	F	50	60	75	Hz
Vertical Section	Period	T_V	1092	1130	1653	T_line
	Active	T_{VD}	1080	1080	1080	
	Blanking	T_{VB}	12	50	573	
Horizontal Section	Period	T_H	1004	1050	1100	T_clock
	Active	T_{HD}	960	960	960	
	Blanking	T_{HB}	44	90	140	

Note: DE mode only.

Note: Typical value refer to VESA STANDARD

6.4.2 Input Timing Diagram

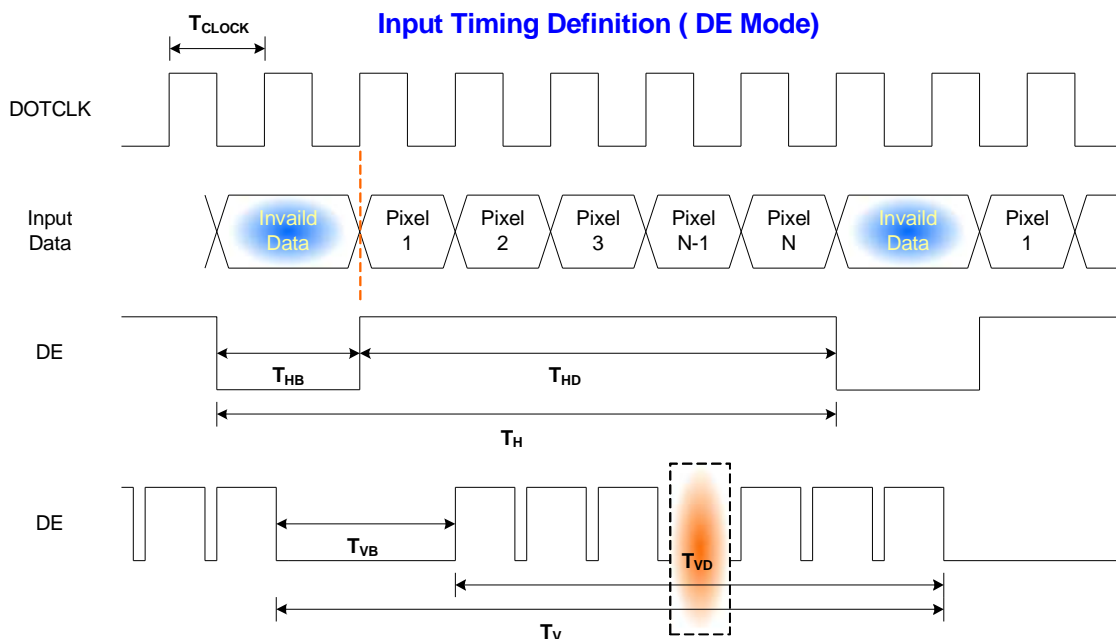

6.5 Power ON/OFF Sequence

VDD power and B/L on/off sequence is as below. Interface signals are also shown in the chart. Signals from any system shall be Hi-Z state or low level when VDD is off.

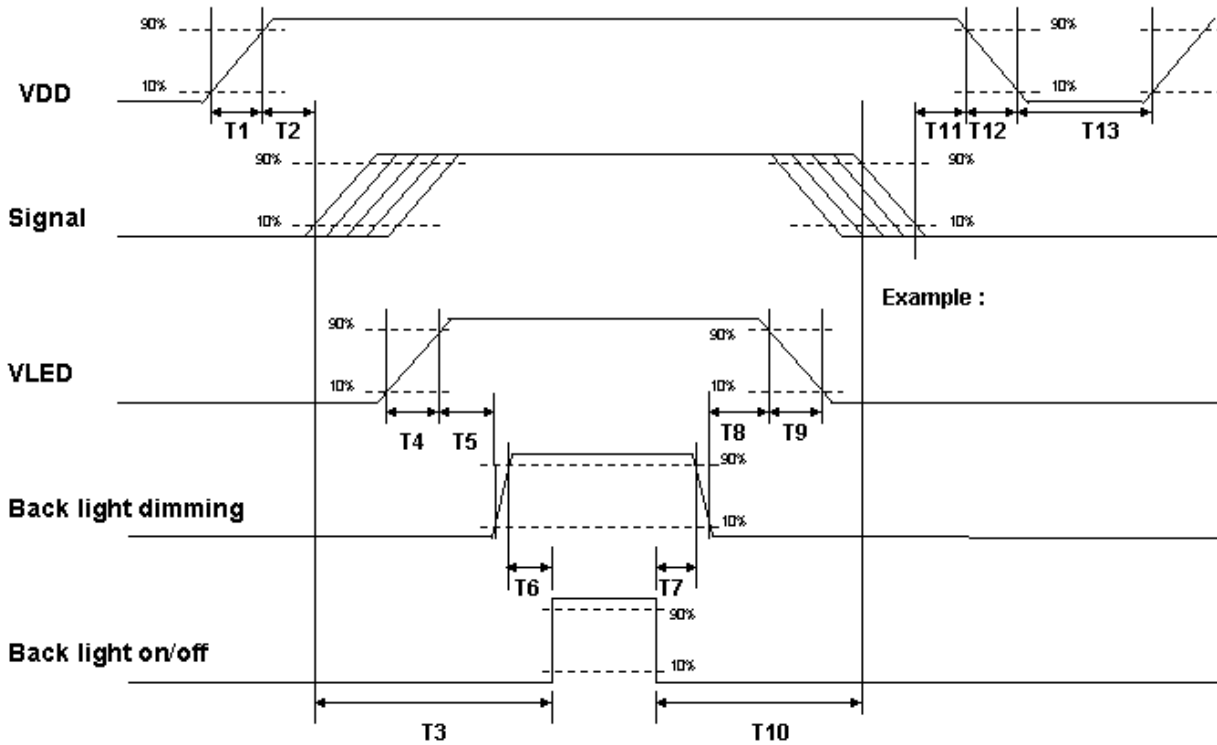

Power ON/OFF sequence timing

Parameter	Value			Units
	Min.	Typ.	Max.	
T1	0.5	--	10	[ms]
T2	30	40	50	[ms]
T3	200	--	--	[ms]
T4	0.5	--	10	[ms]
T5	10	--	--	[ms]
T6	10	--	--	[ms]
T7	0	--	--	[ms]
T8	10	--	--	[ms]
T9	--	--	10	[ms]
T10	110	--	--	[ms]
T11	0	16	50	[ms]
T12	--	--	10	[ms]
T13	1000	--	--	[ms]

The above on/off sequence should be applied to avoid abnormal function in the display. Please make sure to turn



off the power when you plug the cable into the input connector or pull the cable out of the connector.

7. Connector & Pin Assignment

Physical interface is described as for the connector on module. These connectors are capable of accommodating the following signals and will be following components.

7.1 TFT LCD Module: LVDS Connector

Connector Name / Designation	Interface Connector / Interface card
Manufacturer	JAE or compatible
Type Part Number	JAE (FI-XB30SRL-HF11) or equivalent
Mating Housing Part Number	FI-X30HL (JAE) or compatible

Pin#	Signal Name	Pin#	Signal Name
1	RxOIN0-	2	RxOIN0+
3	RxOIN1-	4	RxOIN1+
5	RxOIN2-	6	RxOIN2+
7	GND	8	RxOCLKIN-
9	RxOCLKIN+	10	RxOIN3-
11	RxOIN3+	12	RxEIN0-
13	RxEIN0+	14	GND
15	RxEIN1-	16	RxEIN1+
17	GND	18	RxEIN2-
19	RxEIN2+	20	RxECLKIN-
21	RxECLKIN+	22	RxEIN3-
23	RxEIN3+	24	GND
25	NC	26	NC
27	NC	28	VDD
29	VDD	30	VDD

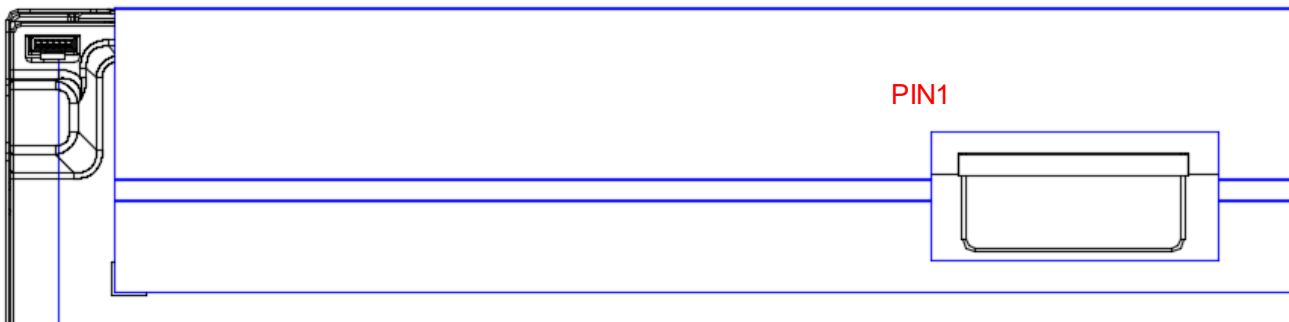

7.2 Backlight Unit: LED Connector

Connector Name / Designation	LED Connector
Manufacturer	ENTERY or compatible
Connector Model Number	ENTERY 3707K-S06N-01(White) or equivalent

PIN #	SIGNAL NAME	DESCRIPTION
1	LED	Negative electrode
2	LED	Negative electrode
3	LED	Positive electrode
4	LED	Positive electrode
5	LED	Negative electrode
6	LED	Negative electrode

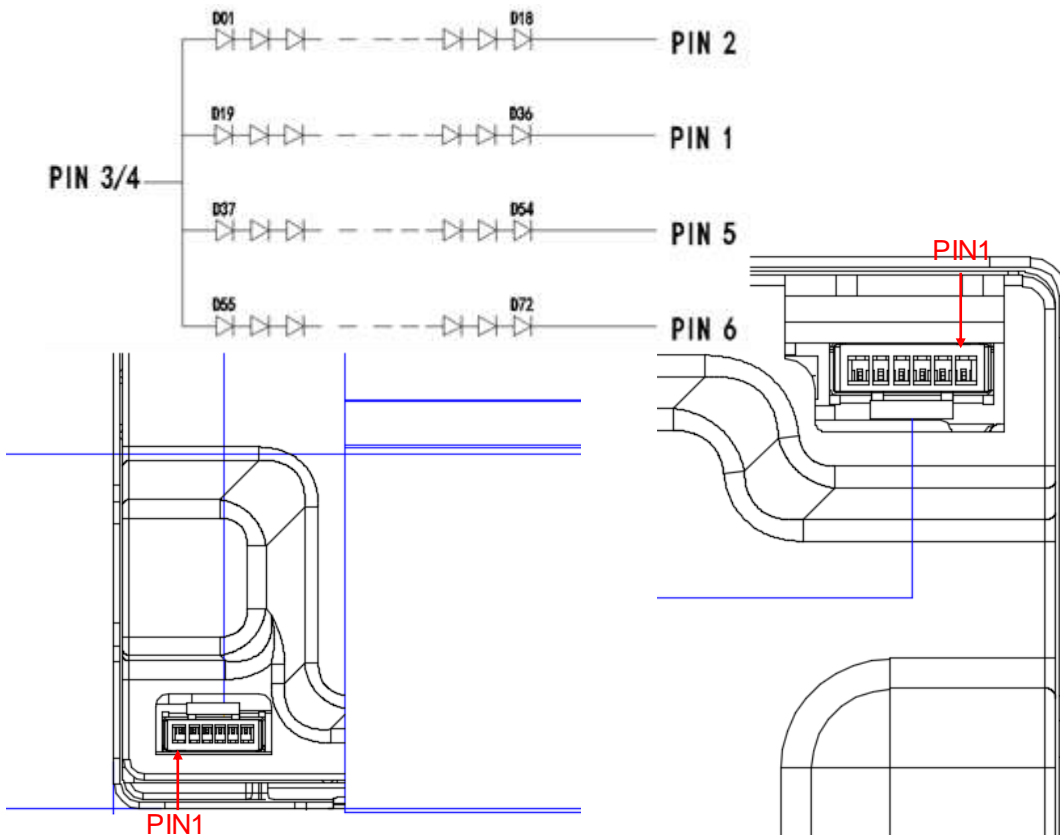

8. Reliability Test

Environment test conditions are listed as following table.

Items	Required Condition	Note
Temperature Humidity Bias (THB)	Ta= 50°C, 80%RH, 300hours	
High Temperature Operation (HTO)	Ta= 80°C, 300hours	
Low Temperature Operation (LTO)	Ta= -10°C, 300hours	
High Temperature Storage (HTS)	Ta= 80°C, 300hours	
Low Temperature Storage (LTS)	Ta= -20°C, 300hours	
Vibration Test (Non-operation)	Acceleration: 1.5 Grms Wave: Random Frequency: 10 - 200 Hz Duration: 30 Minutes each Axis (X, Y, Z)	
Shock Test (Non-operation)	Acceleration: 50 G Wave: Half-sine Active Time: 20 ms Direction: ±X, ±Y, ±Z (one time for each Axis)	
Drop Test	Height: 61 cm, package test	
Thermal Shock Test (TST)	-20°C/30min, 60°C/30min, 100 cycles	1
On/Off Test	On/10sec, Off/10sec, 30,000 cycles	
ESD (Electro Static Discharge)	Contact Discharge: ± 8KV, 150pF(330Ω) 1sec, 15 points, 25 times/ point.	2
	Air Discharge: ± 15KV, 150pF(330Ω) 1sec 15 points, 25 times/ point.	

Note 1: The TFT-LCD module will not sustain damage after being subjected to 100 cycles of rapid temperature change. A cycle of rapid temperature change consists of varying the temperature from -20°C to 60°C, and back again. Power is not applied during the test. After temperature cycling, the unit is placed in normal room ambient for at least 4 hours before power on.

Note2: According to EN61000-4-2, ESD class B: Some performance degradation allowed. No data lost
Self-recoverable. No hardware failures.

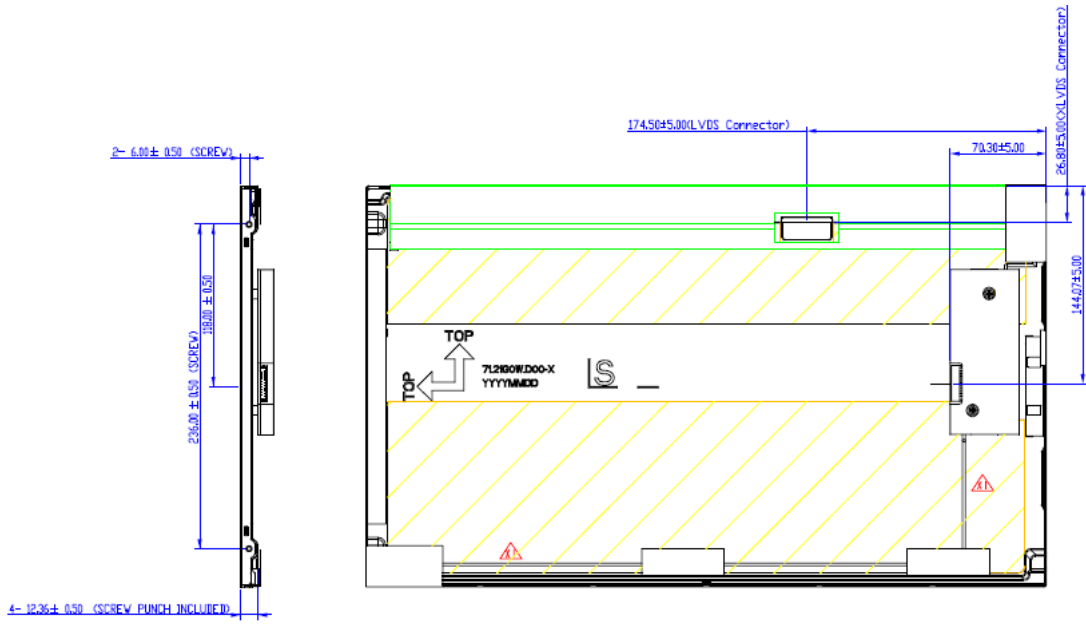

REV	DATE	USER	FILE	SCALE	TOLERANCE	3rd Angle	PROJ. SYM.	PROJ. SYM.
1	10/10							
2	10/10							
3	10/10							
4	10/10							
5	10/10							
6	10/10							
7	10/10							
8	10/10							
9	10/10							
10	10/10							
11	10/10							
12	10/10							
13	10/10							
14	10/10							
15	10/10							
16	10/10							
17	10/10							
18	10/10							
19	10/10							
20	10/10							
21	10/10							
22	10/10							
23	10/10							
24	10/10							
25	10/10							
26	10/10							
27	10/10							
28	10/10							
29	10/10							
30	10/10							
31	10/10							
32	10/10							
33	10/10							
34	10/10							
35	10/10							
36	10/10							
37	10/10							
38	10/10							
39	10/10							
40	10/10							
41	10/10							
42	10/10							
43	10/10							
44	10/10							
45	10/10							
46	10/10							
47	10/10							
48	10/10							
49	10/10							
50	10/10							
51	10/10							
52	10/10							
53	10/10							
54	10/10							
55	10/10							
56	10/10							
57	10/10							
58	10/10							
59	10/10							
60	10/10							
61	10/10							
62	10/10							
63	10/10							
64	10/10							
65	10/10							
66	10/10							
67	10/10							
68	10/10							
69	10/10							
70	10/10							
71	10/10							
72	10/10							
73	10/10							
74	10/10							
75	10/10							
76	10/10							
77	10/10							
78	10/10							
79	10/10							
80	10/10							
81	10/10							
82	10/10							
83	10/10							
84	10/10							
85	10/10							
86	10/10							
87	10/10							
88	10/10							
89	10/10							
90	10/10							
91	10/10							
92	10/10							
93	10/10							
94	10/10							
95	10/10							
96	10/10							
97	10/10							
98	10/10							
99	10/10							
100	10/10							

10. Label and Packaging

10.1 Shipping Label (on the rear side of TFT-LCD display)

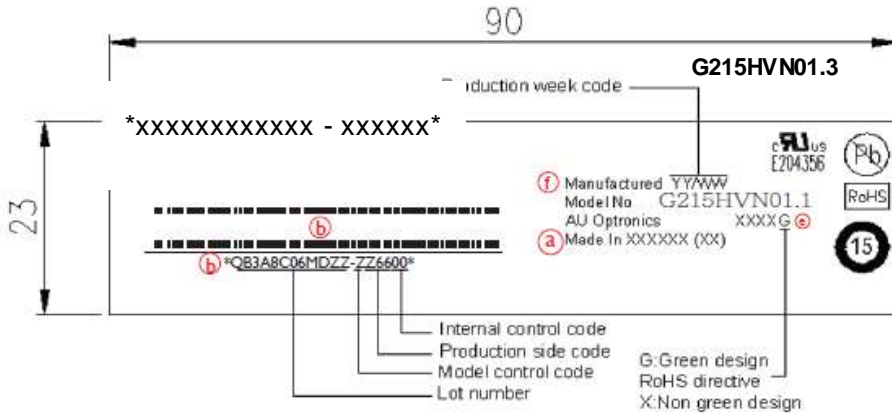

Part No.	Model Name
97.21G01.300	G215HVN01.3

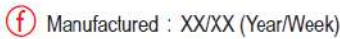
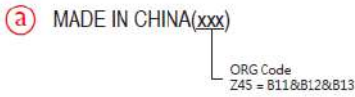
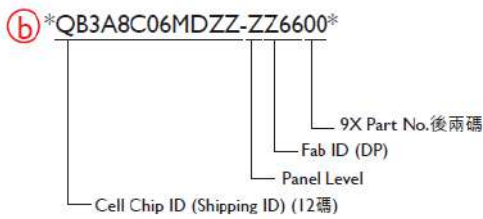

10.2 Carton Package

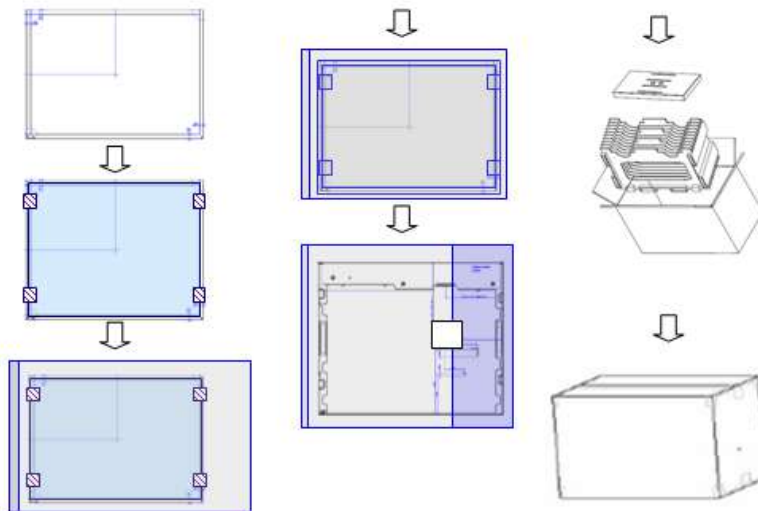

靜電袋包裝方式 Module insert into anti-static bag

手动包装:

1. 取静电袋(79.21G01.001);
- 2 把 module 短边先插入静电袋开口;
3. 开口处多余的静电袋折向模组背面
4. 贴封口胶带

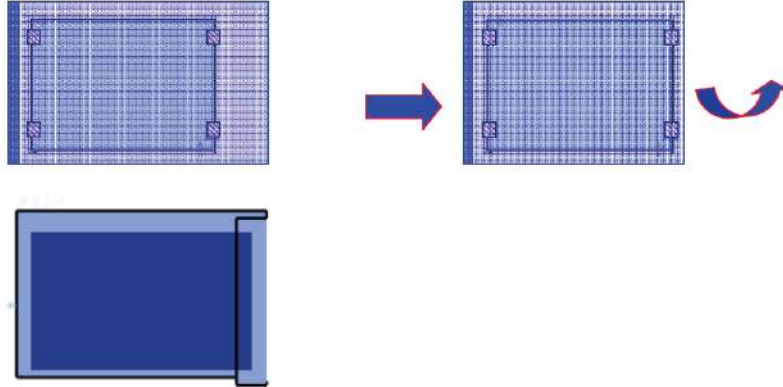

Max capacity : 7 pcs per carton

Max weight: 30.9 kg per carton

Outside dimension of carton: 602mm*372mm*367mm

Pallet size : 1280mm*1150mm*132mm

10.3 Carton Label

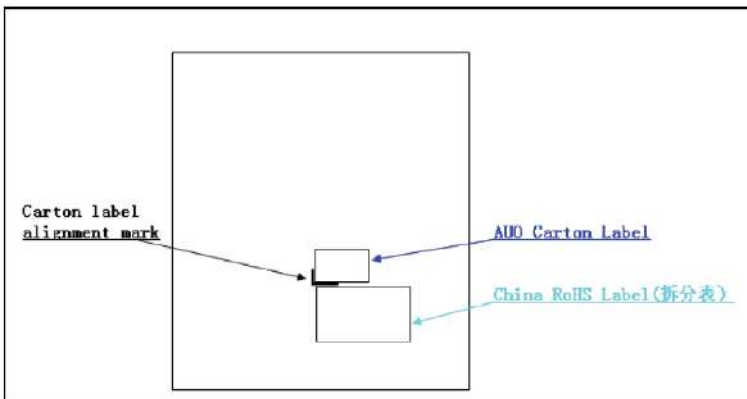

※貼附於紙箱右面L角標註位置

AU Optronics	QTY :	RoHS	Pb
MODEL NO : (a)			
PART NO : (b)			
CUSTOMER NO :			
CARTON NO :			
	(c)		
	ZS0601-10A3100001		
Made in China			

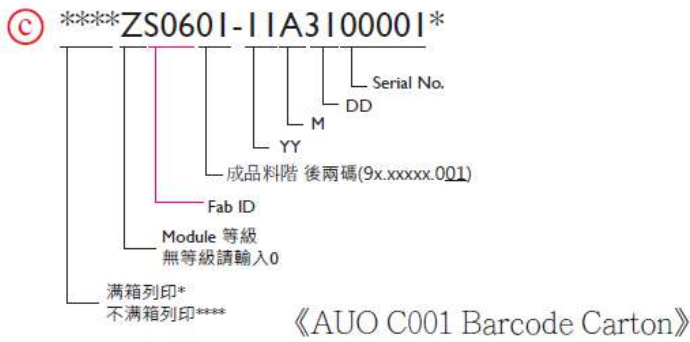

Part No.	Model Name
97.21G01.300	G215HVN01.3



11. Safety

11.1 Sharp Edge Requirements

There will be no sharp edges or comers on the display assembly that could cause injury.

11.2 Materials

11.2.1 Toxicity

There will be no carcinogenic materials used anywhere in the display module. If toxic materials are used, they will be reviewed and approved by the responsible AUO toxicologist.

11.2.2 Flammability

All components including electrical components that do not meet the flammability grade UL94-V1 in the module will complete the flammability rating exception approval process

The printed circuit board will be made from material rated 94-V1 or better. The actual UL flammability rating will be printed on the printed circuit board.

11.3 Capacitors

If any polarized capacitors are used in the display assembly, provisions will be made to keep them from being inserted backwards.

11.4 National Test Lab Requirement

The display module will satisfy all requirements for compliance to:

UL 1950, First Edition

U.S.A. Information Technology Equipment