



() Preliminary Specifications
(V) Final Specifications

Module	15 Inch Color TFT-LCD
Model Name	G150XTN06.A

Customer	Date
<p style="text-align: center;">Checked & Approved by</p> <p style="text-align: center;">_____</p>	<p style="text-align: center;">_____</p>

Approved by	Date
<p>_____ Sean Lin _____</p>	<p>_____ 20190221 _____</p>
<p>Prepared by</p>	
<p>_____ Ryan Chen _____</p>	<p>_____ 20190221 _____</p>
<p>General Display Business Unit / AU Optronics corporation</p>	

Contents

1. Operating Precautions	4
2. General Description	5
2.1 Display Characteristics	5
2.2 Optical Characteristics.....	6
3. Functional Block Diagram	9
4. Absolute Maximum Ratings.....	10
4.1 Absolute Ratings of TFT LCD Module.....	10
4.2 Absolute Ratings of Environment.....	10
5. Electrical Characteristics	11
5.1 TFT LCD Module	11
5.2 Backlight Unit	13
6. Signal Characteristic	14
6.1 Pixel Format Image	14
6.2 Scanning Direction	14
6.3 Signal Description.....	15
6.4 The Input Data Format.....	16
6.5 Interface Timing	17
6.6 Power ON/OFF Sequence	18
7. Connector & Pin Assignment	19
7.1 TFT LCD Module: LVDS Connector	19
7.2 Backlight Unit: LED Driver Connector	21
7.3 LED Connector Pin Assignment.....	21
8. Reliability Test Criteria	22
9. Mechanical Characteristics	23
9.1 LCM Outline Dimension (Front View and back view)	23
10. Label and Packaging	25
10.1 Shipping Label (on the rear side of TFT-LCD display)	25
10.2 Carton Package.....	25
10.3 Palletizing	26
11 Safety	27
11.1 Sharp Edge Requirements.....	27
11.2 Materials	27
11.3 Capacitors	27
11.4 National Test Lab Requirement.....	27



Record of Revision

Version and Date	Page	Old description	New Description
0.0 2018/06/01	All	First Edition	
1.0 2019/02/21	All	Final Vresion	

1. Operating Precautions

- 1) Since front polarizer is easily damaged, please be cautious and not to scratch it.
- 2) Be sure to turn off power supply when inserting or disconnecting from input connector.
- 3) Wipe off water drop immediately. Long contact with water may cause discoloration or spots.
- 4) When the panel surface is soiled, wipe it with absorbent cotton or soft cloth.
- 5) Since the panel is made of glass, it may be broken or cracked if dropped or bumped on hard surface.
- 6) Since CMOS LSI is used in this module, take care of static electricity and insure human earth when handling.
- 7) Do not open nor modify the module assembly.
- 8) Do not press the reflector sheet at the back of the module to any direction.
- 9) In case if a module has to be put back into the packing container slot after it was taken out from the container, do not press the center of the LED Reflector edge. Instead, press at the far ends of the LED Reflector edge softly. Otherwise the TFT Module may be damaged.
- 10) At the insertion or removal of the Signal Interface Connector, be sure not to rotate nor tilt the Interface Connector of the TFT Module.
- 11) TFT-LCD Module is not allowed to be twisted & bent even force is added on module in a very short time. Please design your display product well to avoid external force applying to module by end-user directly.
- 12) Small amount of materials without flammability grade are used in the TFT-LCD module. The TFT-LCD module should be supplied by power complied with requirements of Limited Power Source (IEC60950-1 or UL60950-1), or be applied exemption.
- 13) Severe temperature condition may result in different luminance, response time.
- 14) Continuous operating TFT-LCD Module under high temperature environment may accelerate LED light bar exhaustion and reduce luminance dramatically.
- 15) The data on this specification sheet is applicable when TFT-LCD module is placed in landscape position.
- 16) Continuous displaying fixed pattern may induce image sticking. It's recommended to use screen saver or moving content periodically if fixed pattern is displayed on the screen.

2. General Description

G150XTN06.A is a Color Active Matrix Liquid Crystal Display composed of a TFT-LCD display, a driver circuit, and a backlight system. The screen format is intended to support XGA (1024(H) x 768(V)) screen and 16.2M or 262K colors. All input signals are LVDS interface compatible. All design rules of this module can correspond to PSWG standard.

G150XTN06.A is designed for industrial display applications.

2.1 Display Characteristics

The following items are characteristics summary on the table under 25 °C condition:

Items	Unit	Specifications
Screen Diagonal	[inch]	15
Active Area	[mm]	304.128(H) x 228.096(V)
Pixels H x V		1024x3(RGB) x 768
Pixel Pitch	[mm]	0.297 x 0.297
Pixel Arrangement		R.G.B. Vertical Stripe
Display Mode		TN, Normally White
Nominal Input Voltage VDD	[Volt]	3.3 typ.
Typical Power Consumption	[Watt]	23.81W
Weight	[Grams]	1000g (max.)
Physical Size	[mm]	326.5(H)x 253.5(V) x 10.0(D) (max.)
Electrical Interface		LVDS
Surface Treatment		Anti-Reflection,3H
Support Color		16.2M/262K
Temperature Range Operating Storage (Non-Operating)	[°C] [°C]	-30 to +70 -30 to +70
RoHS Compliance		RoHS Compliance
Light Bar Unit		LED, non-replaceable

2.2 Optical Characteristics

The optical characteristics are measured under stable conditions at 25°C (Room Temperature):

Item	Unit	Conditions	Min.	Typ.	Max.	Note
White Luminance	[cd/m2]		1600	1800	-	1
Uniformity	%	9 Points	75	80	-	1, 2, 3
Contrast Ratio			400	800	-	4
Cross talk	%		-	1.2	1.5	5
Response Time	[msec]	Rising	-	5.7		6
	[msec]	Falling	-	2.3		
	[msec]	Raising + Falling	-	8		
Viewing Angle	[degree]	Horizontal (Right) CR = 10 (Left)	70	80	-	7
	[degree]		70	80	-	
	[degree]	Vertical (Upper) CR = 10 (Lower)	60	70	-	
Color / Chromaticity Coordinates (CIE 1931)		Red x	0.547	0.597	0.647	
		Red y	0.289	0.339	0.389	
		Green x	0.279	0.329	0.379	
		Green y	0.546	0.596	0.646	
		Blue x	0.104	0.154	0.204	
		Blue y	0.003	0.053	0.103	
		White x	0.263	0.313	0.363	
		White y	0.279	0.329	0.379	
Color Gamut	%			60	-	

Note 1: Measurement method

Equipment Pattern Generator, Power Supply, Digital Voltmeter, Luminance meter (SR_3 or equivalent)

Aperture 1° with 50cm viewing distance

Test Point Center

Environment < 1 lux

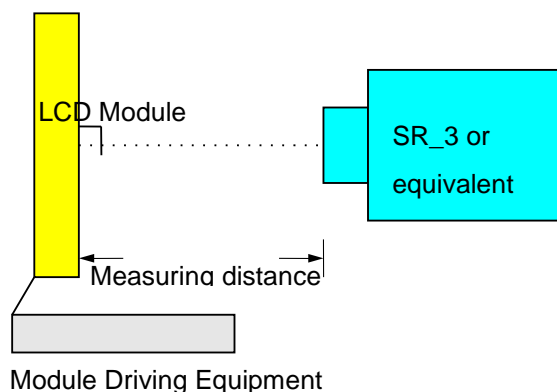

Note 2: Definition of 9 points position (Display active area : 304.128(H) x 228.096(V))

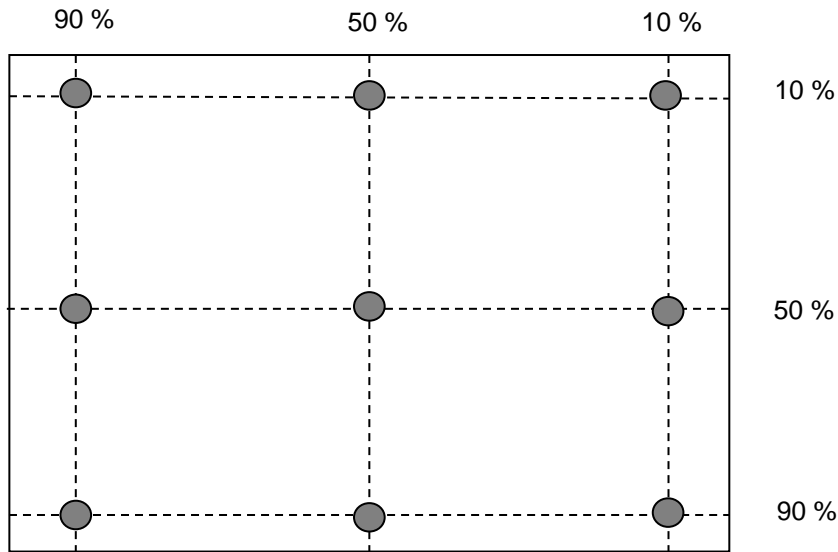

Note 3: The luminance uniformity of 9 points is defined by dividing the minimum luminance values by the maximum test point luminance

$$\delta_{w9} = \frac{\text{Minimum Brightness of nine points}}{\text{Maximum Brightness of nine points}}$$

Note 4 : Definition of contrast ratio (CR):

$$\text{Contrast ratio (CR)} = \frac{\text{Brightness on the "White" state}}{\text{Brightness on the "Black" state}}$$

Note 5 : Definition of cross talk (CT)

$$CT = |YB - YA| / YA \times 100 (\%)$$

Where

YA = Luminance of measured location without gray level 0 pattern (cd/m2)

YB = Luminance of measured location with gray level 0 pattern (cd/m2)

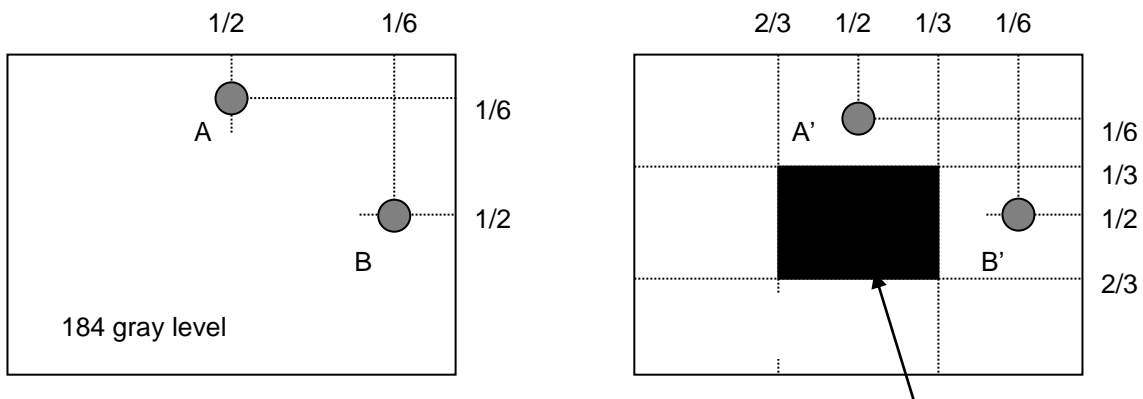

Note 6: Definition of response time:

The output signals of photo detector are measured when the input signals are changed from “White” to “Black” (falling time) and from “Black” to “White” (rising time), respectively. The response time interval is between 10% and 90% of amplitudes. Please refer to the figure as below.

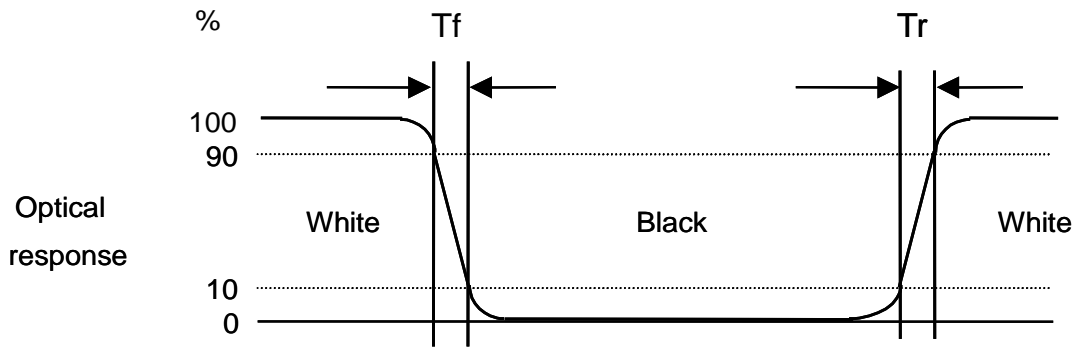

Note 7: Definition of viewing angle

Viewing angle is the measurement of contrast ratio ≥ 10 , at the screen center, over a 180° horizontal and 180° vertical range (off-normal viewing angles). The 180° viewing angle range is broken down as below: 90° (θ) horizontal left and right, and 90° (Φ) vertical high (up) and low (down). The measurement direction is typically perpendicular to the display surface with the screen rotated to its center to develop the desired measurement viewing angle.

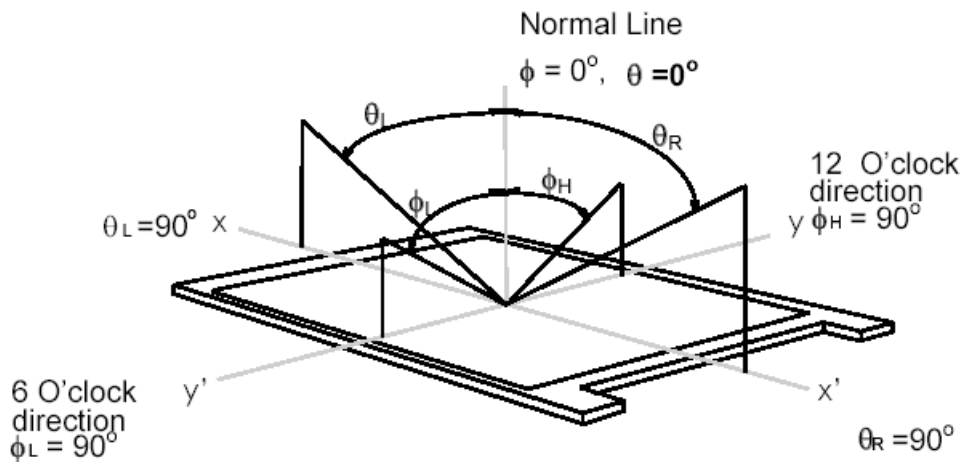

3. Functional Block Diagram

The following diagram shows the functional block of the 15 inch color TFT/LCD module:

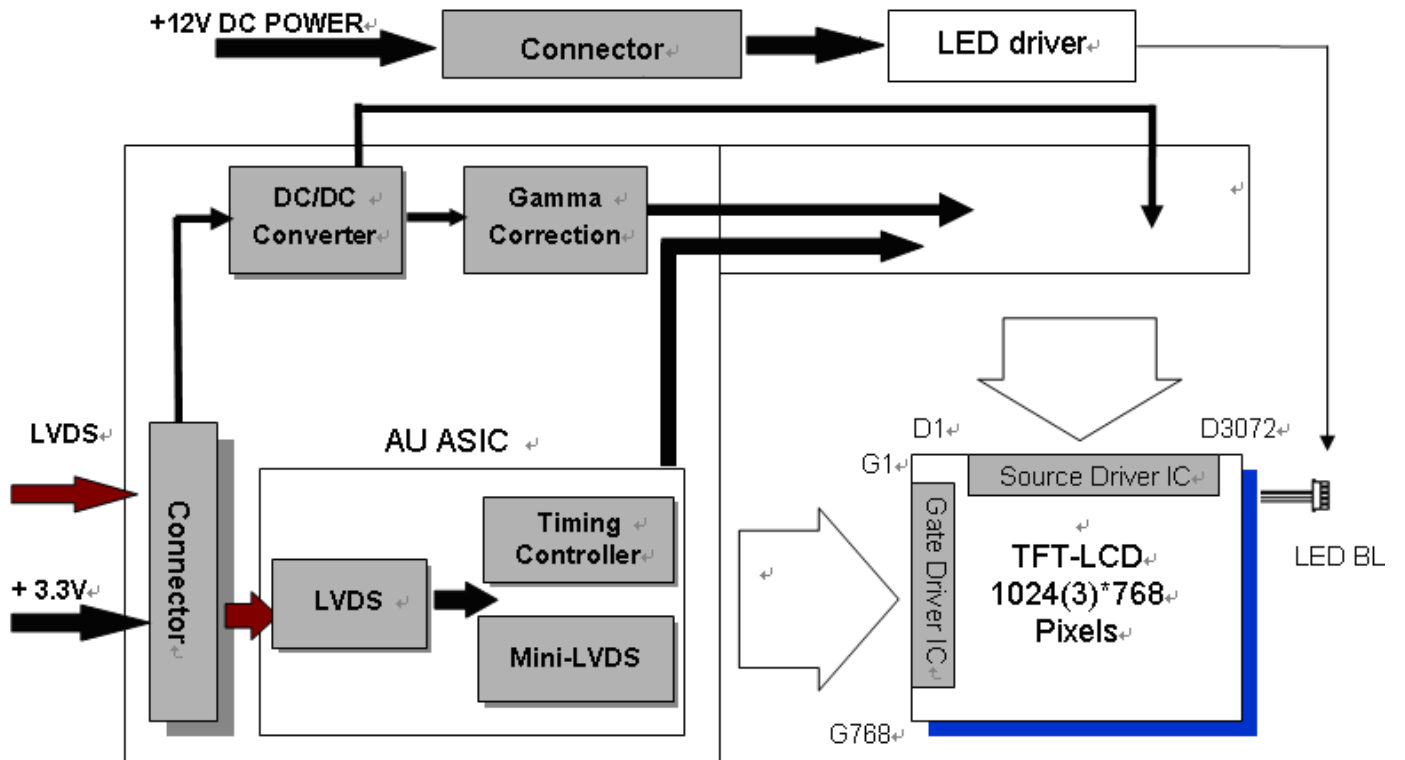

4. Absolute Maximum Ratings

4.1 Absolute Ratings of TFT LCD Module

Item	Symbol	Min	Max	Unit
Logic/LCD Drive Voltage	Vin	-0.3	+3.6	[Volt]

4.2 Absolute Ratings of Environment

Item	Symbol	Min	Max	Unit
Operating Temperature	TOP	-30	+70	[°C]
Operation Humidity	HOP	8	90	[%RH]
Storage Temperature	TST	-30	+70	[°C]
Storage Humidity	HST	8	90	[%RH]

Note: Maximum Wet-Bulb should be 39°C and no condensation.

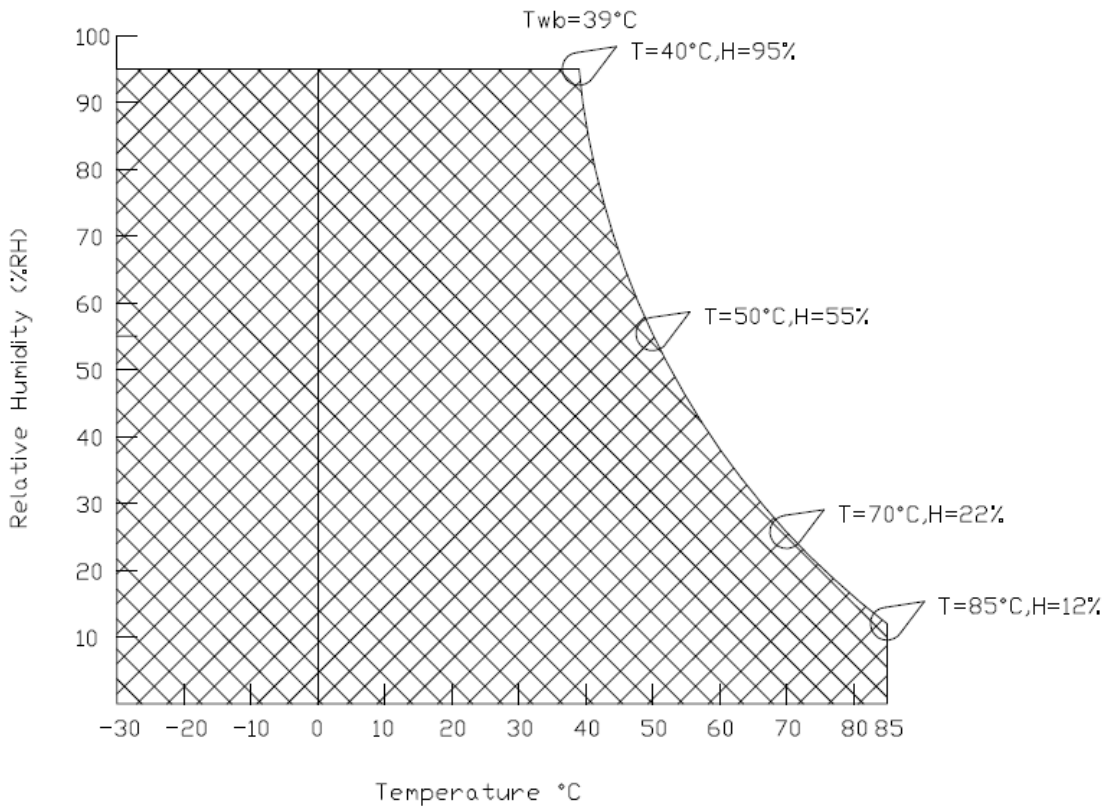

5. Electrical Characteristics

5.1 TFT LCD Module

5.1.1 Power Specification

Symbol	Parameter	Min	Typ	Max	Units	Remark
VDD	Logic/LCD Drive Voltage	3.0	3.3	3.6	[Volt]	± 10%
IDD	VDD Current	-	1	1.2	[A]	Black pattern VDD=Typ.3.3 V, at 60Hz)
Irush	LCD Inrush Current	-	-	3	[A]	Note 1
PDD	VDD Power	-	3.3	3.96	[Watt]	Black pattern VDD=Typ.3.3 V, at 60Hz)

Note 1: Measurement condition:

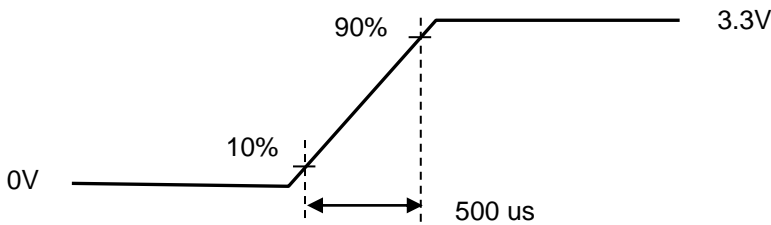
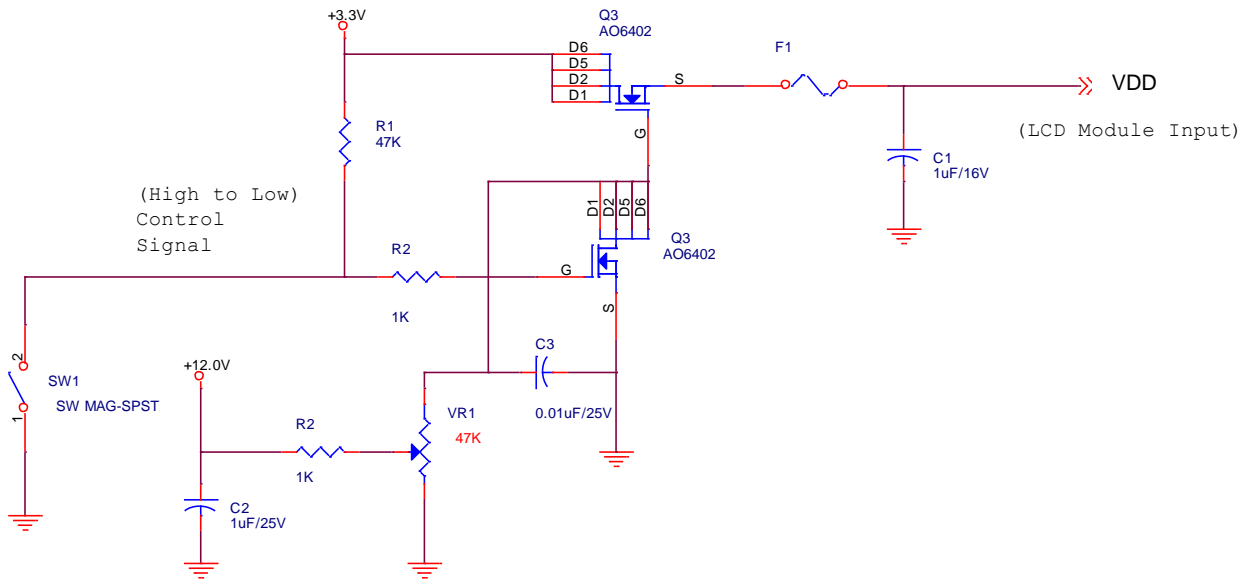

VDD rising time

5.1.2 Signal Electrical Characteristics

Input signals shall be low or Hi-Z state when VDD is off.

Symbol	Item	Min.	Typ.	Max.	Unit	Remark
VTH	Differential Input High Threshold	-	-	+100	[mV]	VCM=1.2V
VTL	Differential Input Low Threshold	-100	-	-	[mV]	VCM=1.2V
VID	Input Differential Voltage	100		600	[mV]	
VICM	Differential Input Common Mode Voltage	1.0	1.2	1.5	[V]	VTH/VTL=±100mV

Input signals shall be low or Hi-Z state when VDD is off.

Note: LVDS Signal Waveform.

$V_P - V_N = |VID| > V_{TH} = \text{“High”}$
 $V_P - V_N = -|VID| < V_{TL} = \text{“Low”}$

Single-end Signal

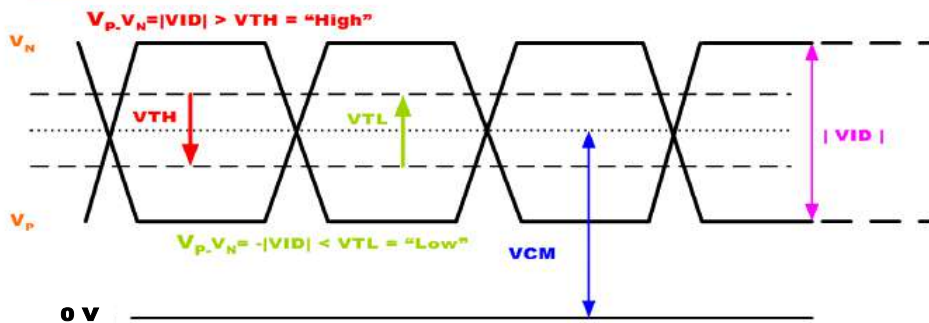

Differential Signal

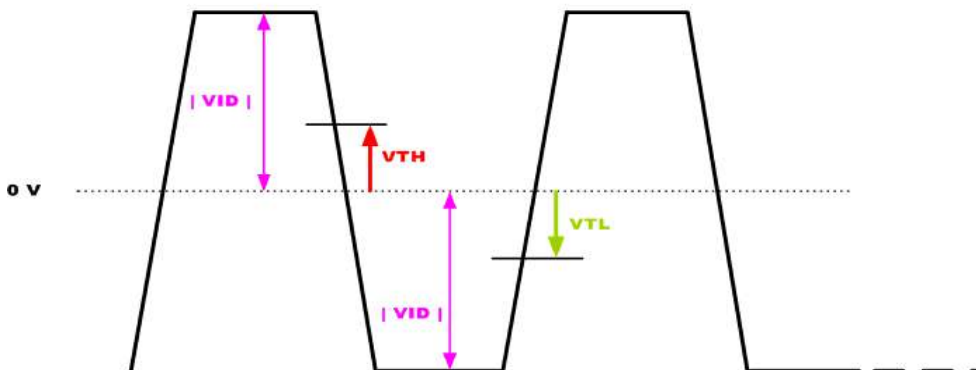

5.2 Backlight Unit

5.2.1 Parameter guideline for LED

Following characteristics are measured under stable condition using a LED driving board at 25°C (Room Temperature).

Symbol	Parameter	Min	Typ	Max	Unit	Remark
V _{cc}	Input Voltage	10.8	12	13.2	Volt	
I _{vcc}	Input Current	-	1.71	1.88	A	100% Dimming
P _{LED}	Power Consumption	-	20.51	22.49	Watt	100% Dimming
I _{rush}	Inrush Current			4	A	
V _{LED on/off}	On Control Voltage	2.5	3.3	5.5	Volt	
	Off Control Voltage			0.7	Volt	
F _{PWM}	PWM Dimming Frequency	200		20k	Hz	
	High Voltage	2.5	3.3	5.5	Volt	
	Low Voltage			0.7	Volt	
	Dimming Duty Cycle	5	-	100	%	
I _F	LED Forward Current		63		mA	Ta = 25°C
LED Life		50,000			Hrs	Ta = 25°C

Note 1: Ta means ambient temperature of TFT-LCD module.

Note 2: If G150XTN06.A module is driven at high ambient temperature & humidity condition. The operating life will be reduced.

Note 3: LED life means brightness goes down to 50% initial brightness. Min. operating life time is estimated data.

6. Signal Characteristic

6.1 Pixel Format Image

Following figure shows the relationship between input signal and LCD pixel format.

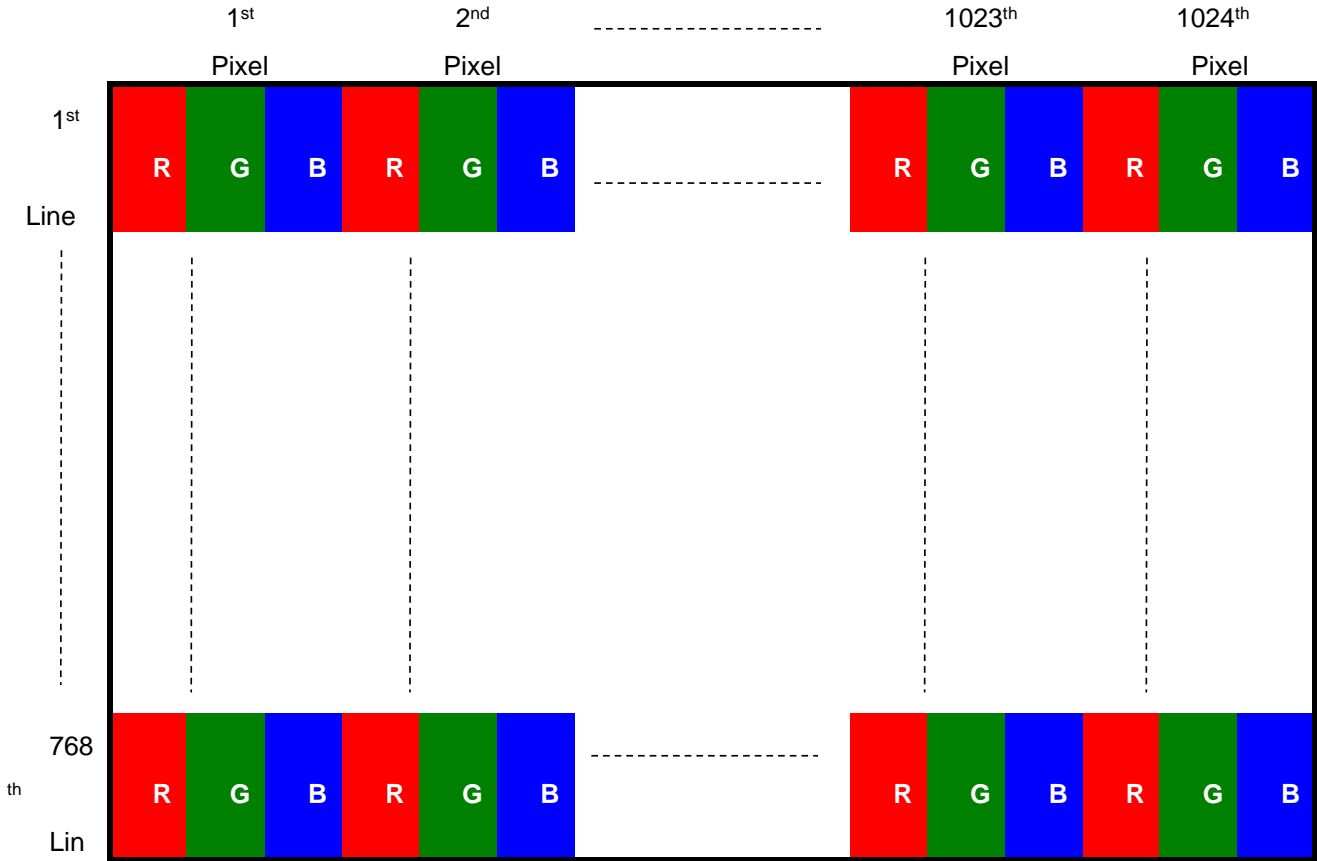

6.2 Scanning Direction

The following figures show the image seen from the front view. The arrow indicates the direction of scan.



6.3 Signal Description

LVDS is a differential signal technology for LCD interface and high speed data transfer device.

Pin No.	Symbol	Description
1	VDD	Power Supply, 3.3V (typical)
2	VDD	Power Supply, 3.3V (typical)
3	NC	No Connect
4	NC	No Connect
5	Rin0-	- LVDS differential data input
6	Rin0+	+ LVDS differential data input
7	VSS	Ground
8	Rin1-	- LVDS differential data input
9	Rin1+	+ LVDS differential data input
10	VSS	Ground
11	Rin2-	- LVDS differential data input
12	Rin2+	+ LVDS differential data input
13	VSS	Ground
14	ClkIN-	- LVDS differential clock input
15	ClkIN+	+ LVDS differential clock input
16	VSS	Ground
17	Rin3-	- LVDS differential data input
18	Rin3+	+ LVDS differential data input
19	VSS	Ground
20	SEL LVDS	H or NC: 6bit/L: 8bit

6.4 The Input Data Format

SEL LVDS = "H" or NC for 6 bits LVDS Input

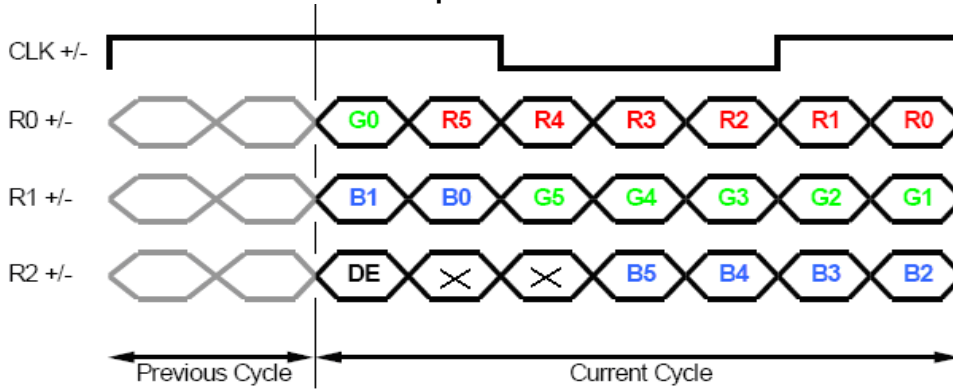

SEL LVDS = "L" for 8 bits LVDS Input

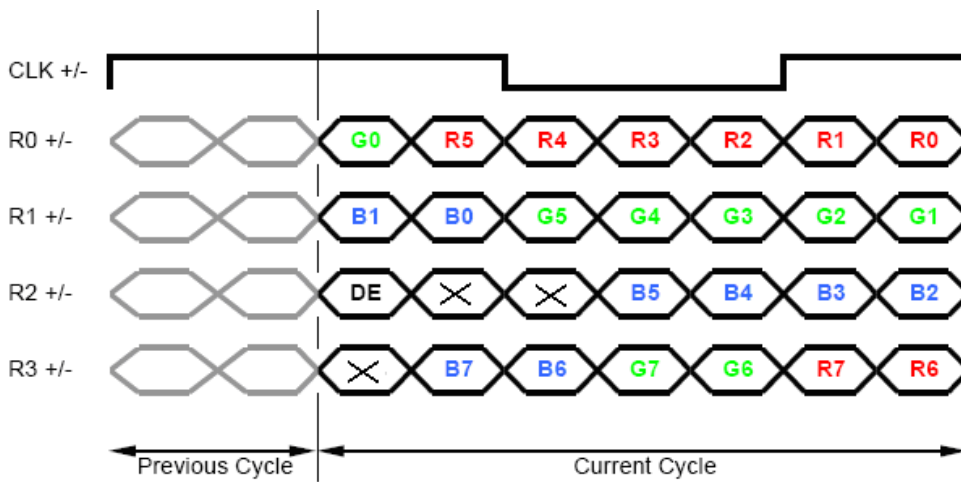

Note1: Please follow PSWG.

Note2: R/G/B data 7:MSB, R/G/B data 0:LSB

6.5 Interface Timing

6.5.1 Timing Characteristics

Signal	Parameter	Symbol	Min.	Typ.	Max.	Unit	
Clock Timing	Clock frequency	$1/T_{Clock}$	50	65	81	MHz	
Vsync Timing	Vertical Section	Period	T_V	783	806	968	Vsync Timing
		Active	T_{VD}	768	768	768	
		Blanking	T_{VB}	15	38	200	
Hsync Timing	Horizontal Section	Period	T_H	1224	1344	2024	Hsync Timing
		Active	T_{HD}	1024	1024	1024	
		Blanking	T_{HB}	200	320	1000	
Frame Rate		F		60		Hz	

Note: The maximum Frame Rate < $81\text{MHz} / [(V_Period) * (H_Period)]$

Note: DE mode only.

Note : Typical value refer to VESA STANDARD

6.5.2 Input Timing Diagram

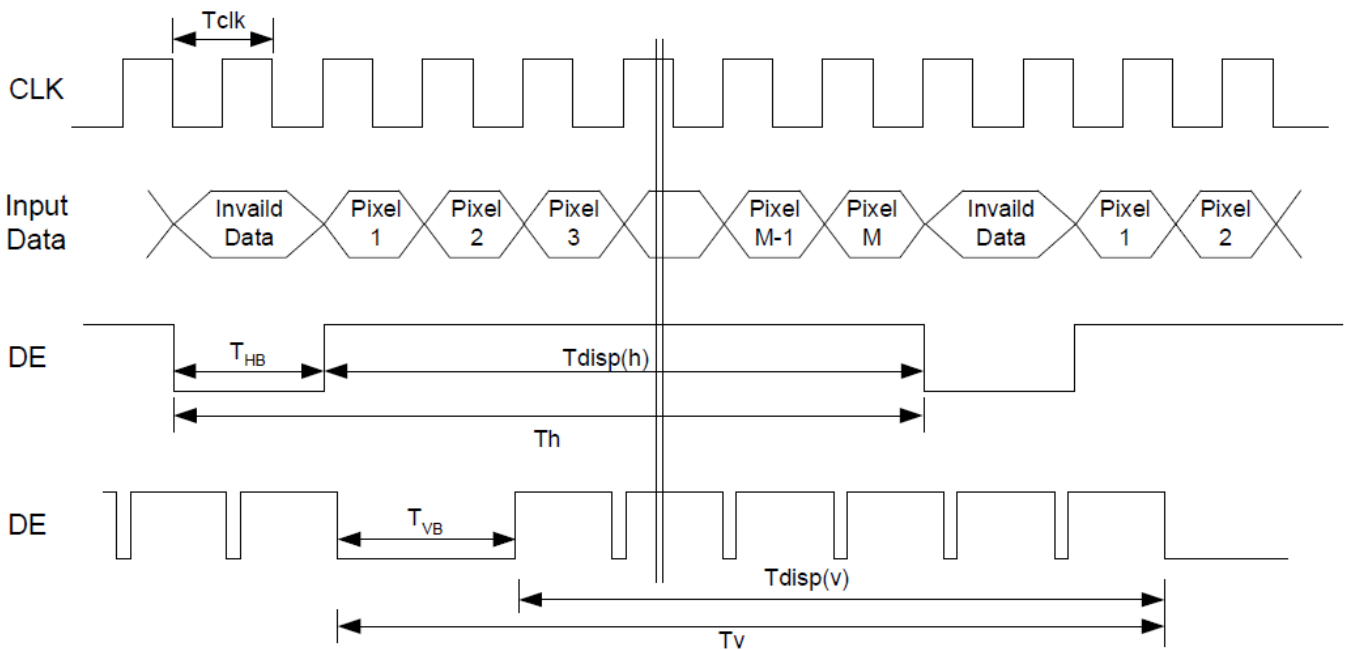

6.6 Power ON/OFF Sequence

VDD power and LED on/off sequence is as below. Interface signals are also shown in the chart. Signals from any system shall be Hi-Z state or low level when VDD is off.

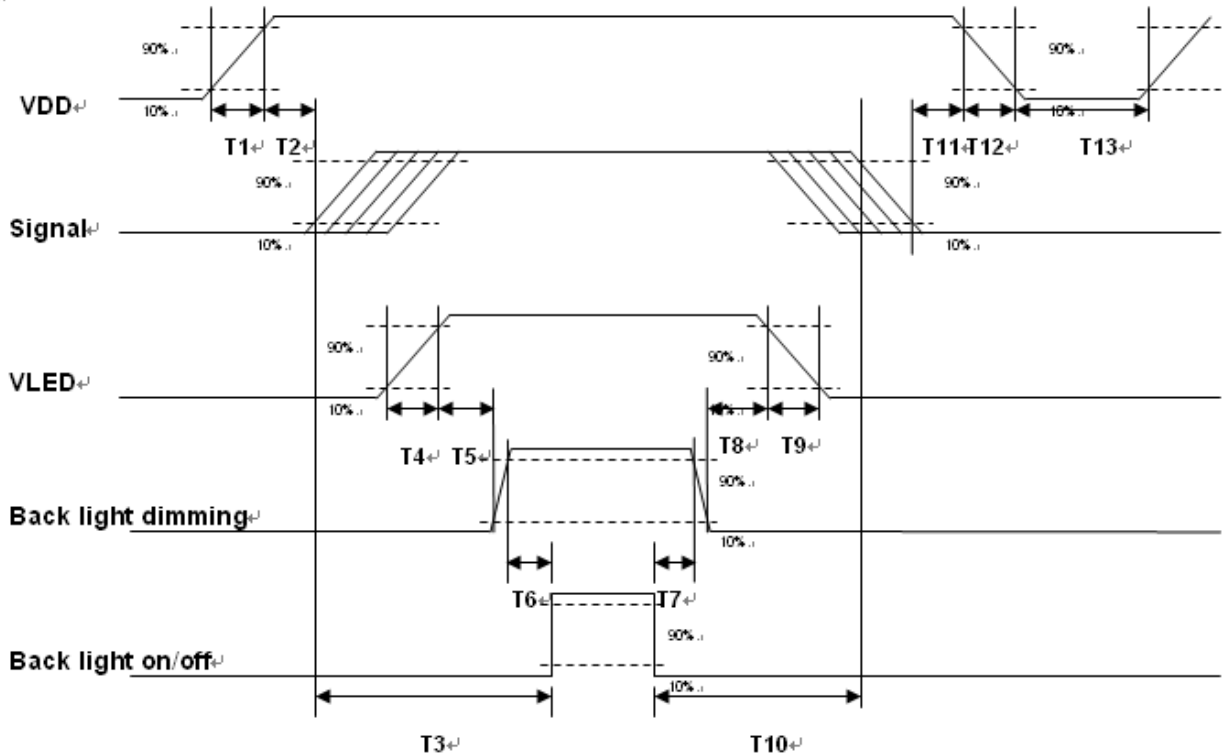

Power ON/OFF sequence timing

Parameter	Value			Units
	Min.	Typ.	Max.	
T1	0.5	-	10	[ms]
T2	30	40	50	[ms]
T3	200	-	-	[ms]
T4	0.5	-	10	[ms]
T5	10	-	-	[ms]
T6	10	-	-	[ms]
T7	0	-	-	[ms]
T8	10	-	-	[ms]
T9	-	-	200	[ms]
T10	110	-	-	[ms]
T11	0	16	50	[ms]
T12	-	-	200	[ms]
T13	1000	-	-	[ms]

The above on/off sequence should be applied to avoid abnormal function in the display. Please make sure to turn off the power when you plug the cable into the input connector or pull the cable out of the connector.

7. Connector & Pin Assignment

Physical interface is described as for the connector on module. These connectors are capable of accommodating the following signals and will be following components.

7.1 TFT LCD Module: LVDS Connector

Connector Name / Designation	Signal Connector
Manufacturer	STM or compatible
Connector Model Number	MSB240420HD or compatible
Mating Model Number	P240420H or compatible

Pin#	Signal Name	Pin#	Signal Name
1	VDD	2	VDD
3	NC	4	NC
5	Rin0-	6	Rin0+
7	VSS	8	Rin1-
9	Rin1+	10	VSS
11	Rin2-	12	Rin2+
13	VSS	14	ClkIN-
15	ClkIN+	16	VSS
17	Rin3-	18	Rin3+
19	VSS	20	SEL68

7.1.1 Connector Illustration

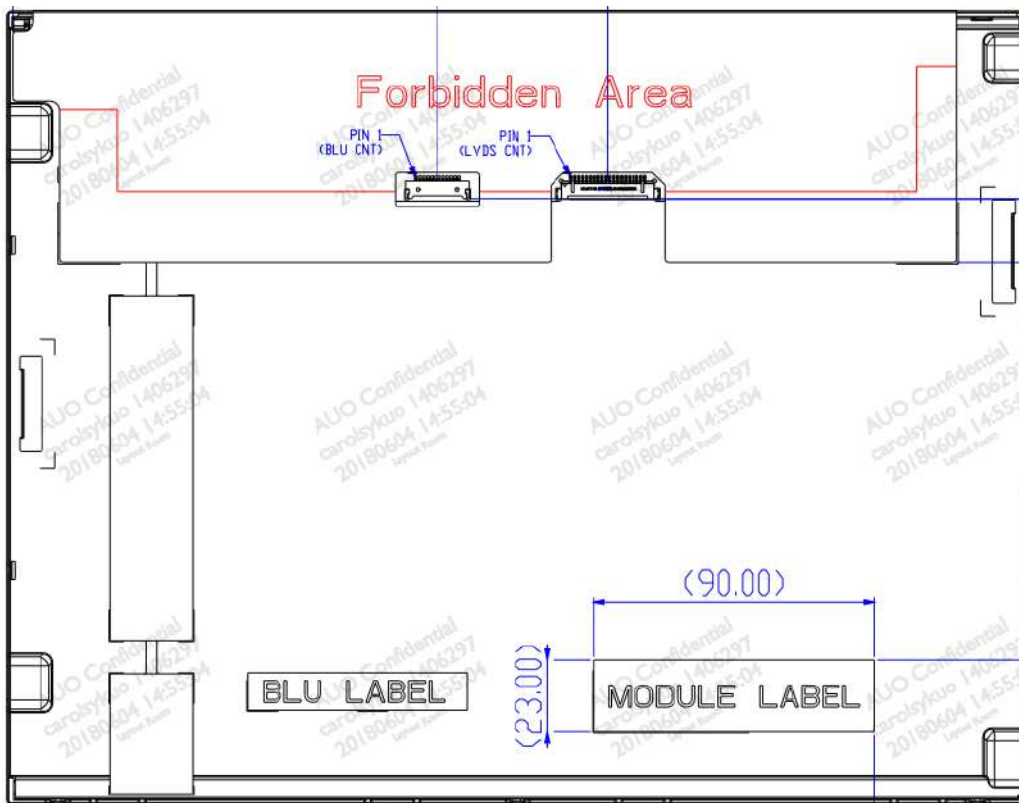

7.2 Backlight Unit: LED Driver Connector

Connector Name / Designation	LED Driver Connector
Manufacturer	ENTERY or compatible
Connector Model Number	3806K-F12N-03L or compatible
Mating Model Number	H208K-D12N-22B or compatible

7.3 LED Connector Pin Assignment

Pin#	Symbol	Signal Name
1	Vcc	Power Supply (Typ. 12V)
2	Vcc	Power Supply (Typ. 12V)
3	Vcc	Power Supply (Typ. 12V)
4	Vcc	Power Supply (Typ. 12V)
5	GND	Ground
6	GND	Ground
7	GND	Ground
8	GND	Ground
9	NC	Non Connection
10	NC	Non Connection
11	Enable	VLED On/Off
12	Dimming	PWM Dimming

8. Reliability Test Criteria

Items	Required Condition	Note
Temperature Humidity Bias	50°C/80%,300 hours	
High Temperature Operation	70°C,300 hours	
Low Temperature Operation	-30°C,300 hours	
Hot Storage	70°C,300 hours	
Cold Storage	-30°C,300 hours	
Thermal Shock Test	-20°C/30 min ,60°C/30 min ,100cycles	
Shock Test (Non-Operating)	50G,20ms,Half-sine wave,(±X, ±Y, ±Z)	
Vibration Test (Non-Operating)	1.5G, (10~200Hz, P-P) 30 mins/axis (X, Y, Z)	
On/off test	On/10 sec, Off/10 sec, 30,000 cycles	
ESD	Contact Discharge: ± 8KV, 150pF(330Ω) 1sec, 8 points, 25 times/ point Air Discharge: ± 15KV, 150pF(330Ω) 1sec, 8 points, 25 times/ point	Note 1

Note1: According to EN61000-4-2, ESD class B: Some performance degradation allowed. No data lost
 . Self-recoverable. No hardware failures.

Note 2:

- Water condensation is not allowed for each test items.
- Each test is done by new TFT-LCD module. Don't use the same TFT-LCD module repeatedly for reliability test.
- The reliability test is performed only to examine the TFT-LCD module capability.
- To inspect TFT-LCD module after reliability test, please store it at room temperature and room humidity for 24 hours at least in advance.
- No function failure occurs. Mura shall be ignored after high temperature reliability test

9. Mechanical Characteristics

9.1 LCM Outline Dimension (Front View and back view)

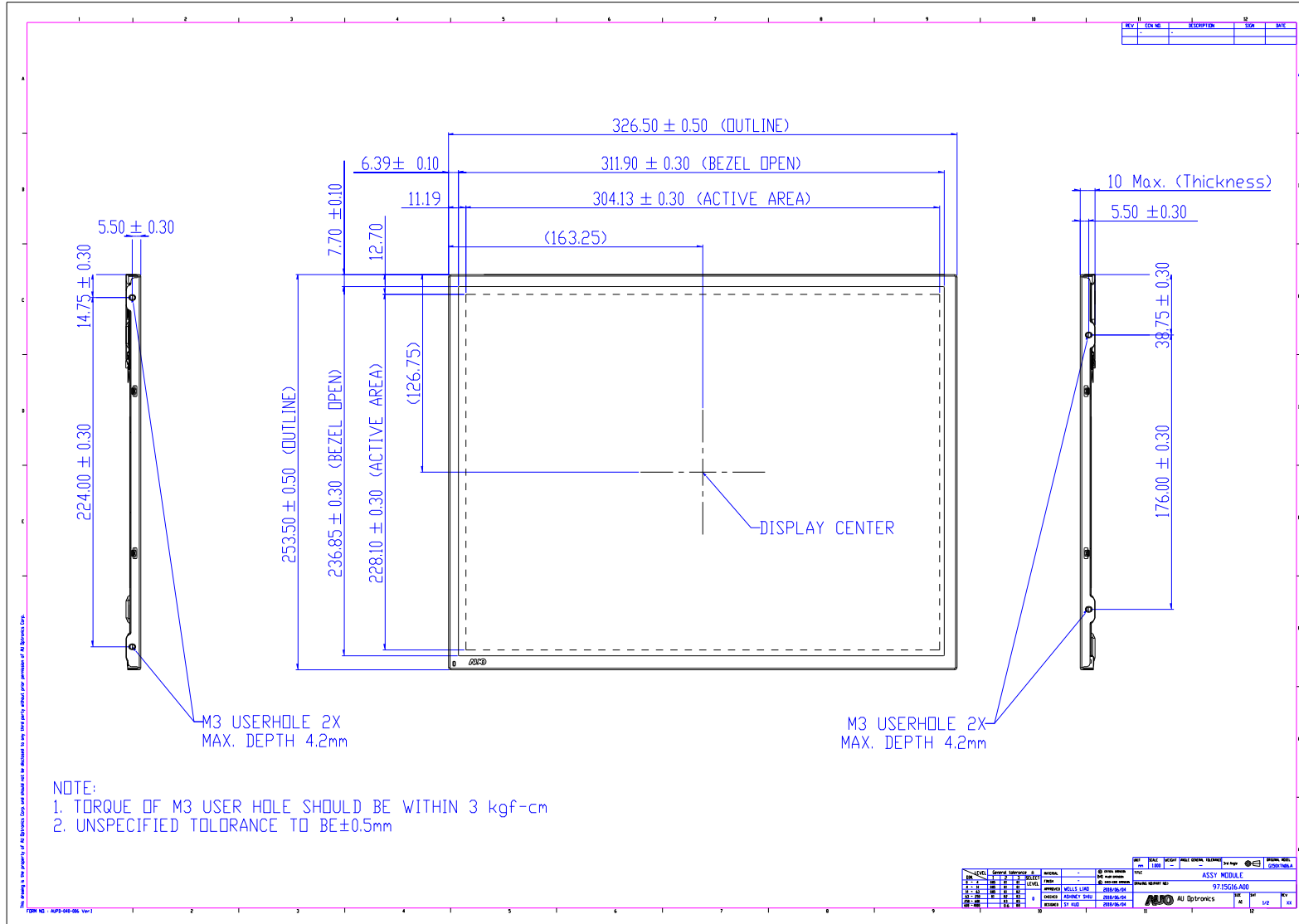

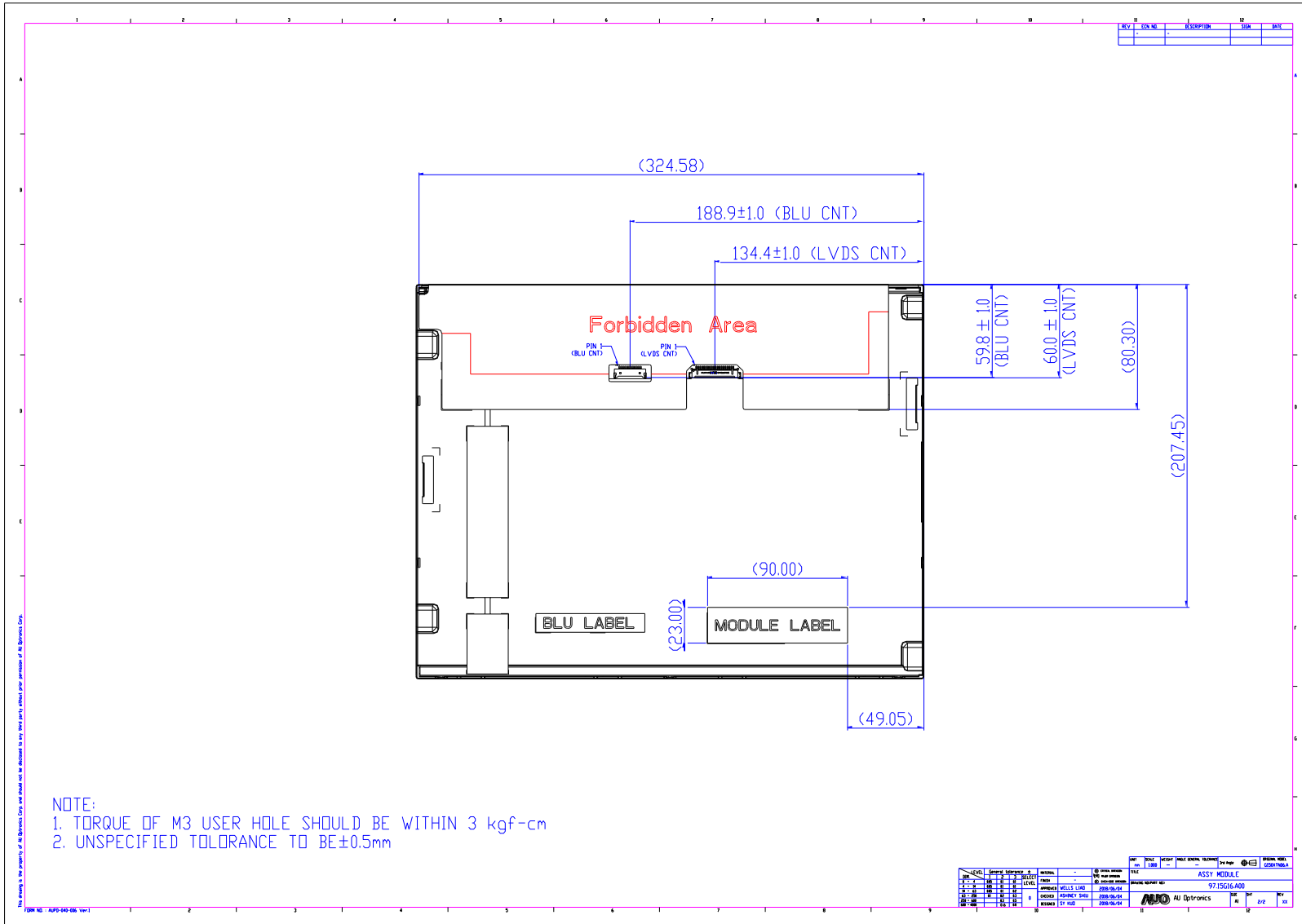

10. Label and Packaging

10.1 Shipping Label (on the rear side of TFT-LCD display)

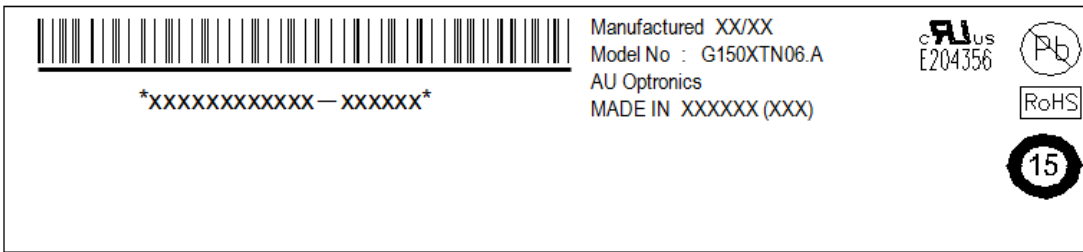

10.2 Carton Package

Max capacity : 14 TFT-LCD module per carton
 Max weight: 16.5 kg per carton
 Outside dimension of carton: 430mm(L)* 370mm(W)*350mm(H)
 Pallet size : 1150 mm * 910 mm * 132mm

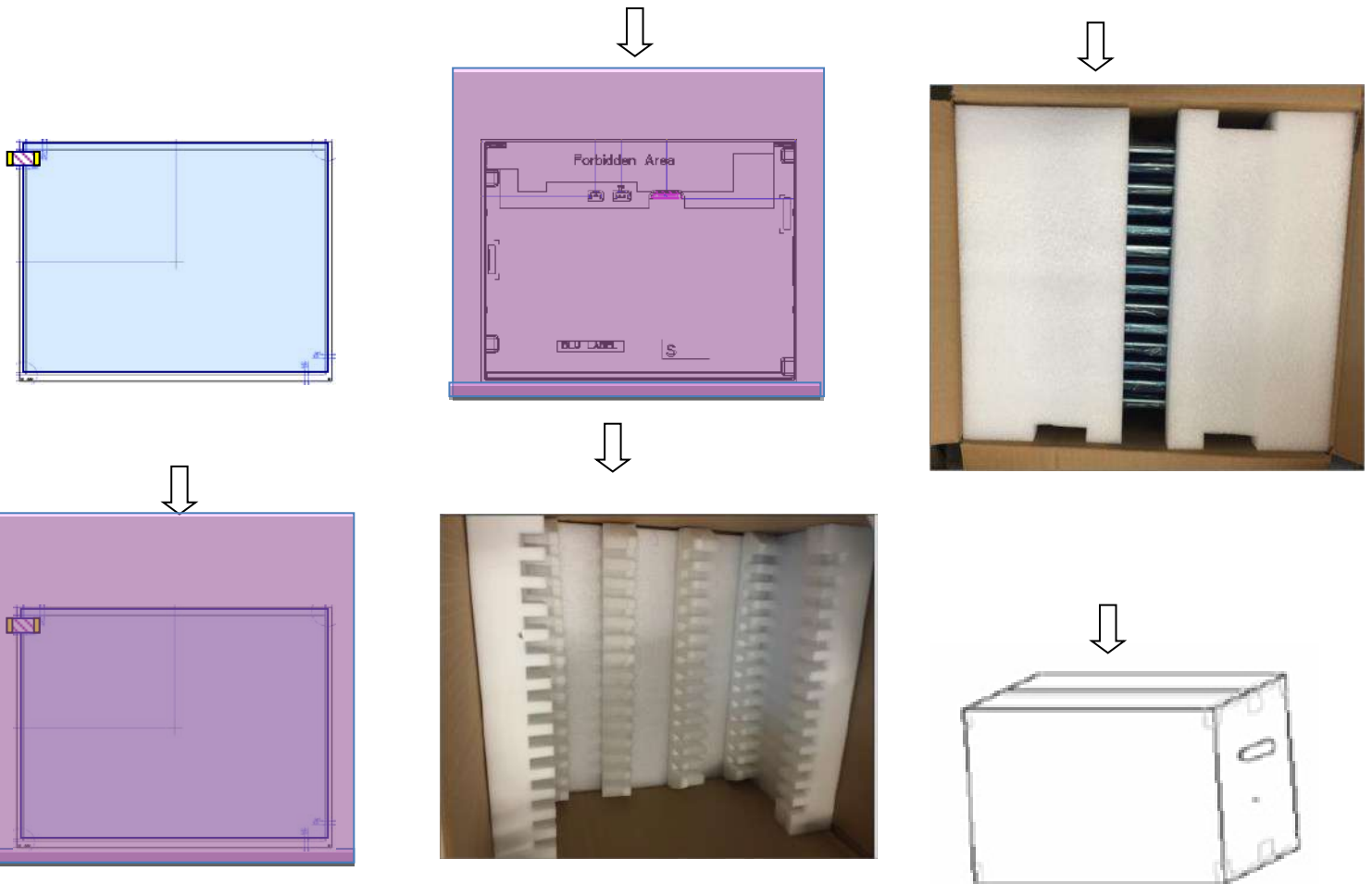

14pcs/Carton

10.3 Palletizing

Module by air_Max: (2 *3) *4 layers , one pallet put 24 boxes , total 336pcs module

Module by sea_Max: (2 *3) *4 layers + (2 *3) *1 layers , two pallet put 30 boxes , total 420pcs module

Module by sea_HQ_Max: (2 *3) *4 layers+(2 *3) *2 layers, two pallet put 36 boxes, total 504pcs module

	SHIPPING BY AIR	SHIPPING BY SEA	SHIPPING BY SEA HQ
MODULE/CARTON	14	14	14
CARTON/LAYER	6	6	6
LAYER/PALLET	4	4+1	4+2
MODULE/PALLET	336	420	504
CARTON SIZE(MM)	430(L)*370(W)*350(H)	430(L)*370(W)*350(H)	430(L)*370(W)*350(H)
PALLET SIZE(MM)	1140(L)*890(W)*132(H)	1140(L)*890(W)*132(H)	1140(L)*890(W)*132(H)
TOTAL PALLET HEIGHT(MM)	1535	2020	2370
TOTAL PALLET WEIGHT(KG)	336	420	504

The diagram illustrates the palletizing process for three shipping methods:

- ONE PALLET SHIPMENT EXAMPLE SHIPPING BY AIR USED:** Shows a single pallet with 24 boxes (2x3x4 layers) secured with stretch film, corner angles, and PET bands.
- TWO PALLETS SHIPMENT EXAMPLE SHIPPING BY SEA USED:** Shows two pallets, each with 15 boxes (2x3x4 layers), secured with stretch film, corner angles, and PET bands.
- TWO PALLETS SHIPMENT EXAMPLE SHIPPING BY SEA_HQ USED:** Shows two pallets, each with 18 boxes (2x3x4 layers + 2x3x1 layers), secured with stretch film, corner angles, and PET bands.

Labels in the diagram include: STRETCH FILM, PALLET, CORNER ANGLE, and PET BAND.

11 Safety

11.1 Sharp Edge Requirements

There will be no sharp edges or comers on the display assembly that could cause injury.

11.2 Materials

11.2.1 Toxicity

There will be no carcinogenic materials used anywhere in the display module. If toxic materials are used, they will be reviewed and approved by the responsible AUO toxicologist.

11.2.2 Flammability

All components including electrical components that do not meet the flammability grade UL94-V1 in the module will complete the flammability rating exception approval process.

The printed circuit board will be made from material rated 94-V1 or better. The actual UL flammability rating will be printed on the printed circuit board.

11.3 Capacitors

If any polarized capacitors are used in the display assembly, provisions will be made to keep them from being inserted backwards.

11.4 National Test Lab Requirement

The display module will satisfy all requirements for compliance to:

UL 60950-1, Second Edition

U.S.A. Information Technology Equipment