

Doc. Number :

Tentative Specification  
Preliminary Specification  
Approval Specification

**MODEL NO.: M280DGJ**  
**SUFFIX: L30**

**Customer: ALL**

**APPROVED BY**

**SIGNATURE**

**Name / Title** \_\_\_\_\_

Note

Product Version C2

\_\_\_\_\_  
Please return 1 copy for your confirmation with your signature and comments.

Approved By	Checked By	Prepared By
梁永祥	陳立錚	徐欣怡

**CONTENTS**

<b>1. GENERAL DESCRIPTION .....</b>	<b>5</b>
1.1 OVERVIEW .....	5
1.2 GENERAL SPECIFICATIONS .....	5
<b>2. MECHANICAL SPECIFICATIONS .....</b>	<b>5</b>
<b>3. ABSOLUTE MAXIMUM RATINGS .....</b>	<b>6</b>
3.1 ABSOLUTE RATINGS OF ENVIRONMENT .....	6
3.2 ELECTRICAL ABSOLUTE RATINGS .....	7
3.2.1 TFT LCD MODULE .....	7
3.2.2 BACKLIGHT UNIT .....	7
<b>4. ELECTRICAL SPECIFICATIONS .....</b>	<b>8</b>
4.1 FUNCTION BLOCK DIAGRAM .....	8
4.2. INTERFACE CONNECTIONS .....	8
4.3 ELECTRICAL CHARACTERISTICS .....	12
4.3.1 LCD ELETRONICS SPECIFICATION .....	12
4.3.2 BACKLIGHT UNIT .....	14
4.3.3 LIGHTBAR Connector Pin Assignment: .....	15
4.4 V by One INPUT SIGNAL SPECIFICATIONS .....	16
4.4.1 V by One DATA MAPPING TABLE .....	16
4.4.2 COLOR DATA INPUT ASSIGNMENT .....	17
4.5 DISPLAY TIMING SPECIFICATIONS .....	18
4.6 V by One Input Signal Timing Diagram .....	20
4.7 Byte Length and Color mapping of V-by-One HS .....	21
4.8 POWER ON/OFF SEQUENCE .....	22
<b>5. OPTICAL CHARACTERISTICS .....</b>	<b>24</b>
5.1 TEST CONDITIONS .....	24
5.2 OPTICAL SPECIFICATIONS .....	24
<b>6. RELIABILITY TEST ITEM .....</b>	<b>27</b>
<b>7. Mechanical Strength Characteristics .....</b>	<b>28</b>
7.1 Mechanical Strength Specifications .....	28
7.2 Test Conditions .....	28
7.3 Definition of Test Points .....	28
<b>8. PACKING .....</b>	<b>29</b>
8.1 PACKING SPECIFICATIONS .....	29
8.2 PACKING METHOD .....	29
8.3 PALLET .....	30

8.4 UN-PACKING METHOD .....	31
<b>9. INX MODULE LABEL .....</b>	<b>32</b>
<b>10. PRECAUTIONS .....</b>	<b>33</b>
10.1 ASSEMBLY AND HANDLING PRECAUTIONS .....	33
10.2 STORAGE PRECAUTIONS .....	33
10.3 OPERATION PRECAUTIONS .....	34
10.4 SAFETY PRECAUTIONS .....	34
10.5 SAFETY STANDARDS .....	34
10.6 OTHER .....	34
<b>Appendix 1. SYSTEM COVER DESIGN NOTICE .....</b>	<b>35</b>
<b>Appendix 2. OUTLINE DRAWING .....</b>	<b>38</b>

## REVISION HISTORY

Version	Date	Page	Description
3.0	10.17, 2013	All	Approval Spec Ver.3.0 was first issued.
3.1	11.23.2013	5	1.2 Total power consumption Cell 11.664 →14.256w Total 34.344→36.936 w
3.2	04.30.2014	Appendixes	Drawing add Back cover add emboss
	05.22.2014	5	1.2 Display Colors_ add the description_ 8 bits.+ High FRC
	06.25.2014	5	Screen Size 27.9" real diagonal
3.3	09,23,2014	6	3.1 ABSOLUTE RATINGS OF ENVIRONMENT 刪除(Ta <40 oC).
		10	BGR > RGB
		11	Power Supply Current
		18	Not 2, Not3
		20	4.8 POWER ON/OFF SEQUENCE
		31	10.2 STORAGE PRECAUTIONS (1)relative humidity of less than 70%--→90%

## 1. GENERAL DESCRIPTION

### 1.1 OVERVIEW

M280DGJ-L30 is a 28.0" TFT Liquid Crystal Display module with WLED Backlight unit and 51 pins 8 lane – V by 1 interface. This module supports 3840 x 2160 UHD(Ultra High Definition) mode and can display up to 1.073G colors. The converter module for Backlight is not built in.

### 1.2 GENERAL SPECIFICATIONS

Item	Specification	Unit	Note
Screen Size	27.9" real diagonal	mm	
Driver Element	a-si TFT active matrix	-	-
Pixel Number	3840 x R.G.B. x 2160	pixel	-
Pixel Pitch	0.16 (H) x 0.16 (V)	mm	-
Pixel Arrangement	RGB vertical stripe	-	-
Display Colors	1.073G (8 bits.+ High FRC)	color	-
Transmissive Mode	Normally White	-	-
Surface Treatment	AG type, 3H hard coating, Haze 25	-	-
Color Gamut	72% of NTSC(Typ.)	-	-
RoHS, Halogen Free & TCO 6.0	RoHS, Halogen Free TCO 6.0 compliance		
Luminance, White	300	Cd/m2	
Power Consumption	Total (36.936) W(Typ.) @ cell (14.256) W(Typ.), BL (22.68)W(Typ.)		(1)

Note (1) The specified power consumption : Total= cell (reference 4.3.1)+BL (reference 4.3.3)

## 2. MECHANICAL SPECIFICATIONS

Item	Min.	Typ.	Max.	Unit	Note	
Module Size	Horizontal (H)	647.90	648.90	649.90	mm	(1)
	Vertical (V)	368.30	369.30	370.30	mm	
	Thickness (T)	18.85	19.85	20.85	mm	
Bezel Area	Horizontal	625.93	626.93	627.93	mm	
	Vertical	346.28	347.28	348.28	mm	
Active Area	Horizontal	-	620.93	-	mm	
	Vertical	-	341.28	-	mm	
Weight	-	2910	3055	g		

Note (1) Please refer to the attached drawings for more information of front and back outline dimensions.

**3. ABSOLUTE MAXIMUM RATINGS**

**3.1 ABSOLUTE RATINGS OF ENVIRONMENT**

Item	Symbol	Value		Unit	Note
		Min.	Max.		
Storage Temperature	TST	-20	60	°C	(1)
Operating Ambient Temperature	TOP	0	50	°C	(1), (2)

Note (1)

(a) 90 %RH Max.

(b) Wet-bulb temperature should be 39 oC Max.

(c) No condensation.

Note (2) The temperature of panel surface should be 0 oC min. and 60 oC max.

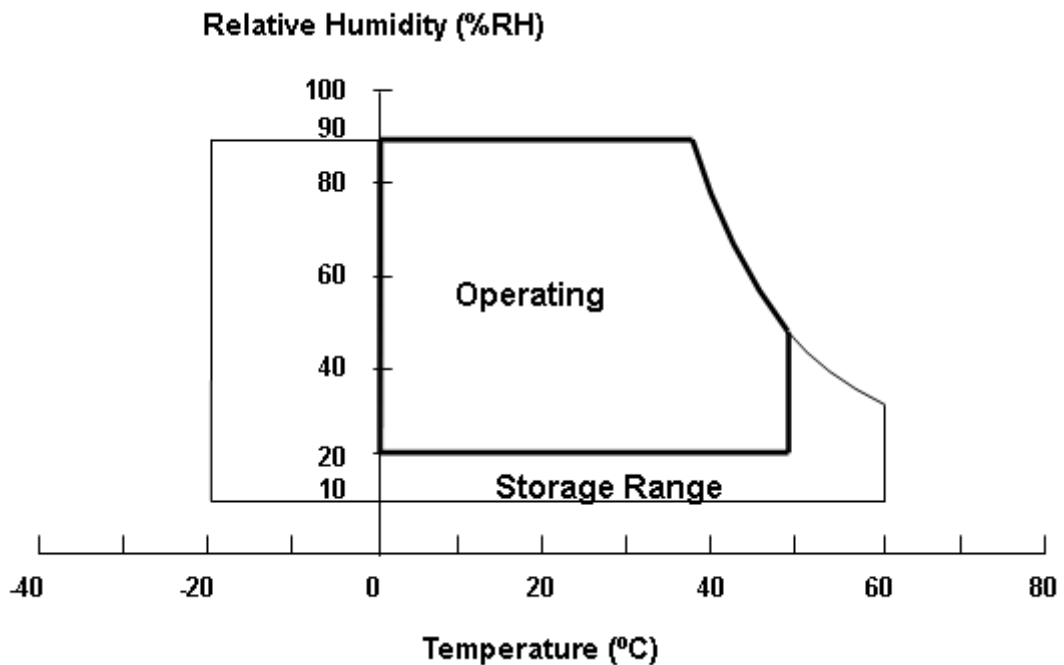

## 3.2 ELECTRICAL ABSOLUTE RATINGS

### 3.2.1 TFT LCD MODULE

Item	Symbol	Value		Unit	Note
		Min.	Max.		
Power Supply Voltage	VCCS	-0.3	13.5.	V	(1)
Logic Input Voltage	VIN	-0.3	3.6	V	

### 3.2.2 BACKLIGHT UNIT

Item	Symbol	Value			Unit	Note
		Min.	Typ	Max.		
LED Forward Current Per Input Pin	IF	141	150	159	mA	(1), (2) Duty=100%

Note (1) Permanent damage to the device may occur if maximum values are exceeded. Function operation should be restricted to the conditions described under Normal Operating Conditions.

Note (2) Specified values are for input pin of LED light bar at  $T_a=25\pm 2$  (Refer to 4.3.2 and 4.3.3 for further information).

**4. ELECTRICAL SPECIFICATIONS**

**4.1 FUNCTION BLOCK DIAGRAM**

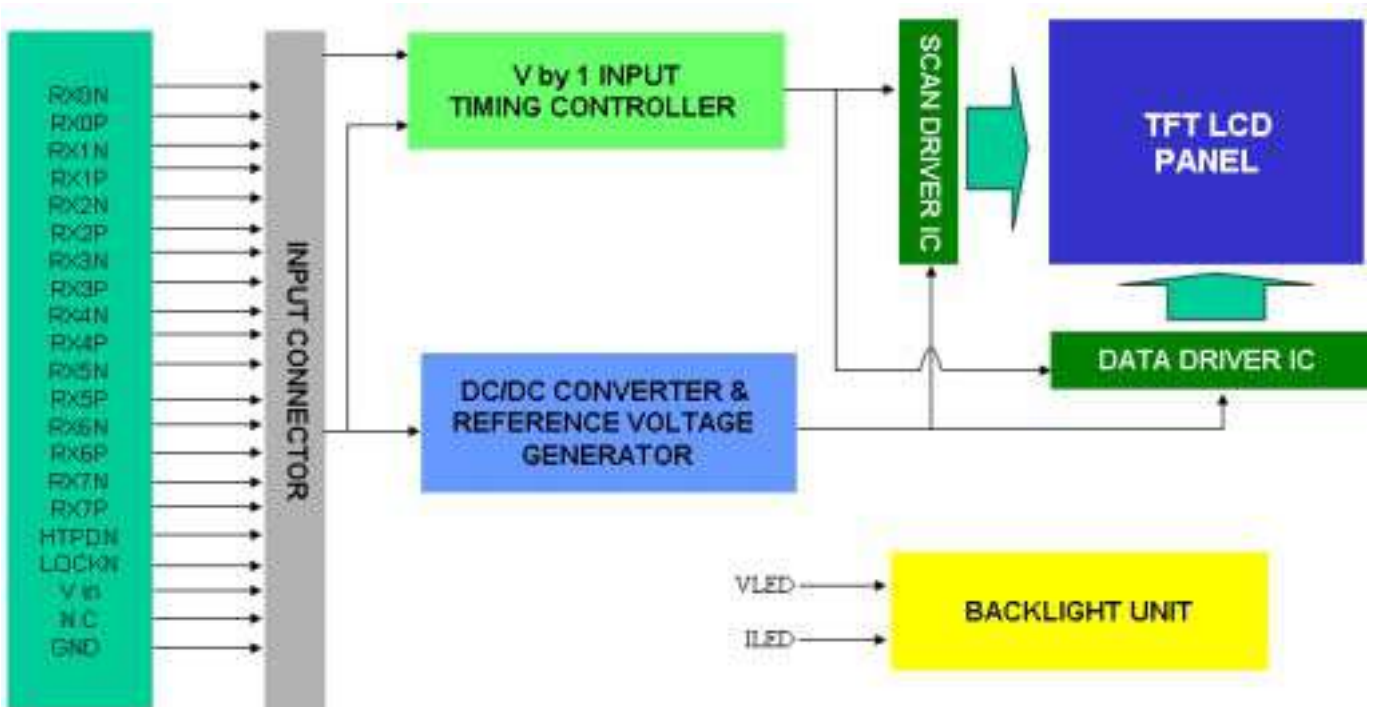

**4.2. INTERFACE CONNECTIONS**

**PIN ASSIGNMENT**

Pin	Name	Description	Note
1	Vin	Power input (+12V)	
2	Vin	Power input (+12V)	
3	Vin	Power input (+12V)	
4	Vin	Power input (+12V)	
5	Vin	Power input (+12V)	
6	Vin	Power input (+12V)	
7	Vin	Power input (+12V)	
8	Vin	Power input (+12V)	
9	N.C.	No Connection	(2)
10	GND	Ground	
11	GND	Ground	
12	GND.	Ground	
13	GND.	Ground	
14	GND.	Ground	
15	N.C.	No Connection	(2)
16	N.C.	No Connection	(2)
17	N.C.	No Connection	(2)
18	N.C	For internal use, no connection	
19	N.C	For internal use, no connection	
20	N.C.	No Connection	(2)
21	N.C.	No Connection	(2)
22	N.C.	No Connection	(2)
23	N.C.	No Connection	(2)



Pin	Name	Description	Note
24	N.C.	No Connection	(2)
25	HTPDN	Hot plug detect output, Open drain.	
26	LOCKN	Lock detect output, Open drain.	
27	GND	Ground	
28	RX0N	1 <sup>st</sup> Pixel Negative VbyOne differential data input in area A. Lan 0	(1)
29	RX0P	1 <sup>st</sup> Pixel Positive VbyOne differential data input in area A. Lan 0	
30	GND	Ground	
31	RX1N	2 <sup>nd</sup> Pixel Negative VbyOne differential data input in area A. Lan 1	(1)
32	RX1P	2 <sup>nd</sup> Pixel Positive VbyOne differential data input in area A. Lan 1	
33	GND	Ground	
34	RX2N	3 <sup>rd</sup> Pixel Negative VbyOne differential data input in area A. Lan 2	(1)
35	RX2P	3 <sup>rd</sup> Pixel Positive VbyOne differential data input in area A. Lan 2	
36	GND	Ground	
37	RX3N	4 <sup>th</sup> Pixel Negative VbyOne differential data input in area A. Lan 3	(1)
38	RX3P	4 <sup>th</sup> Pixel Positive VbyOne differential data input in area A. Lan 3	
39	GND	Ground	
40	RX4N	5 <sup>th</sup> Pixel Negative VbyOne differential data input in area A. Lan 4	(1)
41	RX4P	5 <sup>th</sup> Pixel Positive VbyOne differential data input in area A. Lan 4	
42	GND	Ground	
43	RX5N	6 <sup>th</sup> Pixel Negative VbyOne differential data input in area A. Lan 5	(1)
44	RX5P	6 <sup>th</sup> Pixel Positive VbyOne differential data input in area A. Lan 5	
45	GND	Ground	
46	RX6N	7 <sup>th</sup> Pixel Negative VbyOne differential data input in area A. Lan 6	(1)
47	RX6P	7 <sup>th</sup> Pixel Positive VbyOne differential data input in area A. Lan 6	
48	GND	Ground	
49	RX7N	8 <sup>th</sup> Pixel Negative VbyOne differential data input in area A. Lan 7	(1)
50	RX7P	8 <sup>th</sup> Pixel Positive VbyOne differential data input in area A. Lan 7	
51	GND	Ground	

## Connector Information

Item	Description
Manufacturer	FCN/ P-TWO
Type part number	FCN: WF23-402-5133 P-TWO: 187059-51221
User's Mating housing part number	JAE: FI-RE51HL

\*Notice: There would be compatible issues if not using the indicated connectors in the matching list.

Note (1) V-by-One<sup>®</sup> HS Data Mapping

Lan	Data Stream
Lan 0	1, 9, 17, ....., 3825, 3833
Lan 1	2, 10, 18, ....., 3826, 3834
Lan 2	3, 11, 19, ....., 3827, 3835
Lan 3	4, 12, 20, ....., 3828, 3836
Lan 4	5, 13, 21, ....., 3829, 3837
Lan 5	6, 14, 22, ....., 3830, 3838
Lan 6	7, 15, 23, ....., 3831, 3839
Lan 7	8, 16, 24, ....., 3832, 3840

Note (2) Reserved for internal use. Please leave it open.

Note (3) VbyOne HS connector pin order defined as following:

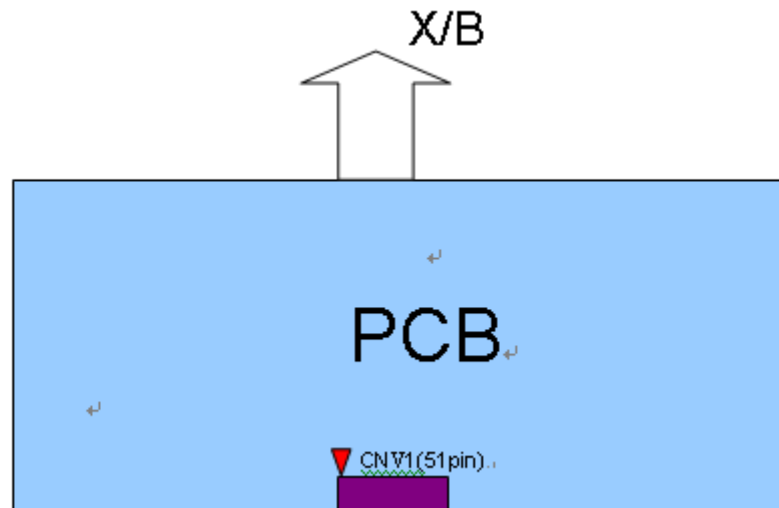

Note (4) V-by-One connector mating dimension range request is 0.93mm~1.0mm as below:

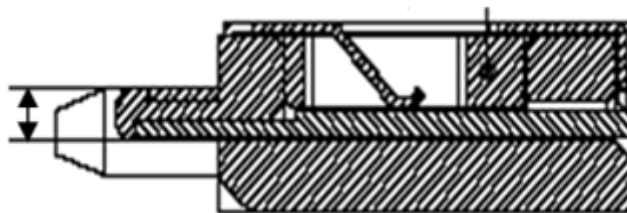

Note (5) The first pixel is odd.

Note (6) Input signal of even and odd clock should be the same timing

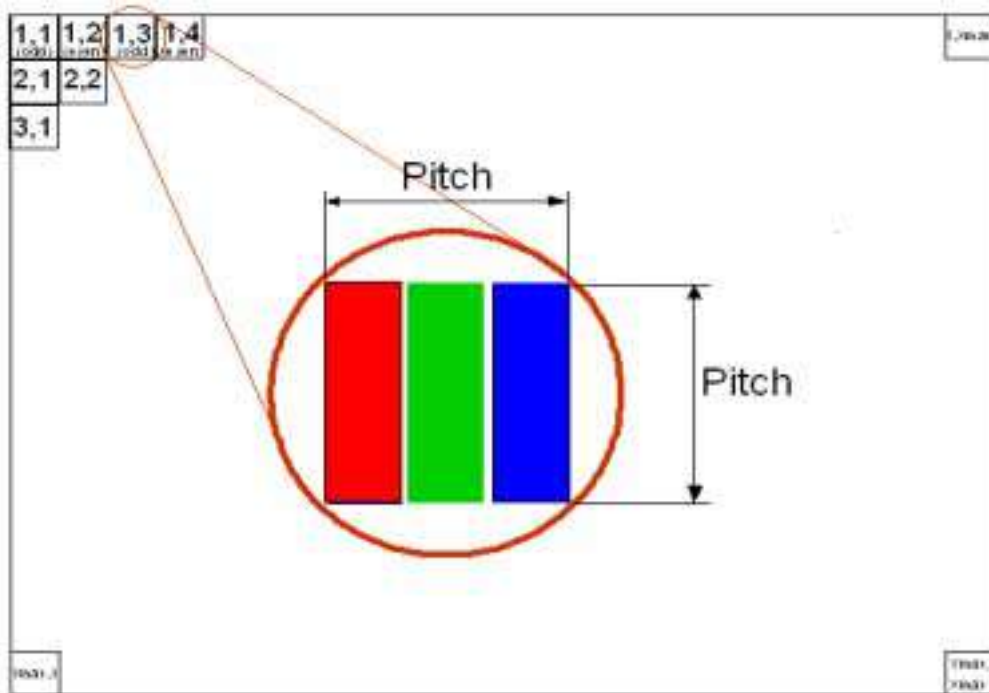

**4.3 ELECTRICAL CHARACTERISTICS**

**4.3.1 LCD ELETRONICS SPECIFICATION**

Parameter		Symbol	Value			Unit	Note
			Min.	Typ.	Max.		
Power Supply Voltage		V <sub>CC</sub>	10.8	12	13.2	V	(2)
Ripple Voltage		V <sub>RP</sub>	-	-	300	mV	-
Rush Current		I <sub>RUSH</sub>	-	2	2.6	A	(3)
Power Supply Current	White	P <sub>T</sub>	-	0.6	0.728	A	(4)a
	Black		-	0.588	0.702	A	(4)b
	Horizontal Stripe		-	1.296	1.573	A	(4)c
Power Consumption		PLCD	-	15.552	18.876	Watt	(5)
V-by-One interface	Differential Input High Threshold Voltage	VLV <sub>TH</sub>	-	-	50	mV	(6)
	Differential Input Low Threshold Voltage	VLV <sub>TL</sub>	-50	-	-	mV	
	Differential Input Resistor	RRIN	80	100	120	ohm	
CMOS interface	Input High Threshold voltage	V <sub>IH</sub>	2.7		3.3	V	
	Input Low threshold voltage	V <sub>IL</sub>	0		0.7	V	

Note (1) The ambient temperature is Ta = 25 ± 2 °C.

Note (2) The module should be always operated within the above ranges. The ripple voltage should be controlled under 10 % of Vcc (Typ.)

Note (3) Measurement Conditions:

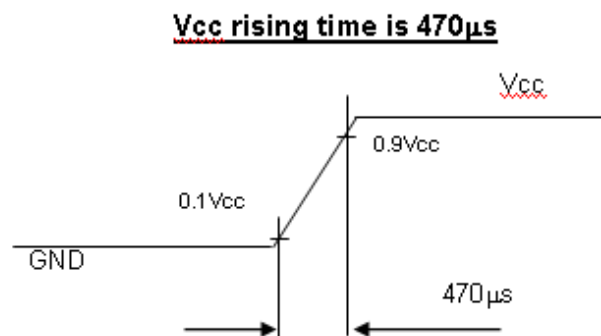

Note (4) The specified power supply current is under the conditions at  $V_{cc} = 12\text{ V}$ ,  $T_a = 25 \pm 2\text{ }^\circ\text{C}$ ,  $F_r = 60\text{ Hz}$ , whereas a power dissipation check pattern below is displayed.

a. White Pattern



Active Area

b. Black Pattern

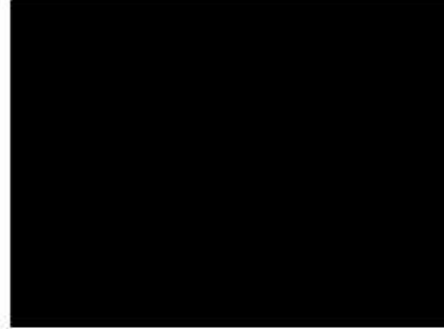

Active Area

c. Horizontal Pattern

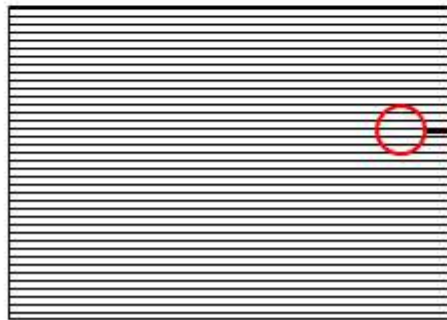

Note (5) The power consumption is specified at the pattern with the maximum current.

**4.3.2 BACKLIGHT UNIT**

Parameter	Symbol	Value			Unit	Note
		Min.	Typ.	Max.		
LED Light Bar Input Voltage Per Input Pin	VPIN	-	37.8	40.2	V	(1), Duty=100%, IPIN=150mA
LED Light Bar Current Per Input Pin	IPIN	141	150	159	mA	(1), (2) Duty=100%
LED Life Time	LLED	30000			Hrs	(3)
Power Consumption	PBL	-	22.68	24.12	W	(1) Duty=100%, IPIN=150mA

Note (1) LED light bar input voltage and current are measured by utilizing a true RMS multimeter as shown below:

Note (2)  $PBL = IPIN \times VPIN \times (4)$  input pins.

Note (3) The lifetime of LED is defined as the time when LED packages continue to operate under the conditions at  $T_a = 25 \pm 2$  and  $I = (150)\text{mA}$  (per chip) until the brightness becomes 50% of its original value.

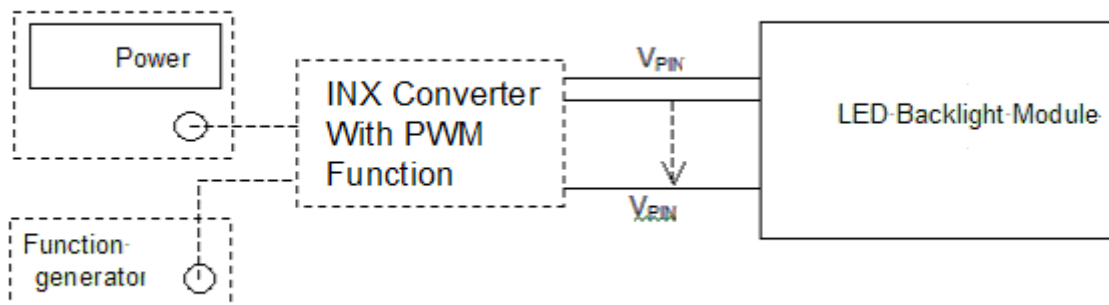

**4.3.3 LIGHTBAR Connector Pin Assignment:**

(1) Connector Information:

Item	Description
Manufacturer	FCN/ CviLux
Type part number	WM13-406-063N(FCN) / C1406M1HRK-NH(CviLux)
Mating housing part number	WF1300106-B (FCN) / C1406SL000-NH (CviLux).

\*Notice: There would be compatible issues if not using the indicated connectors in the matching list.

(2) LB Connector drawing:

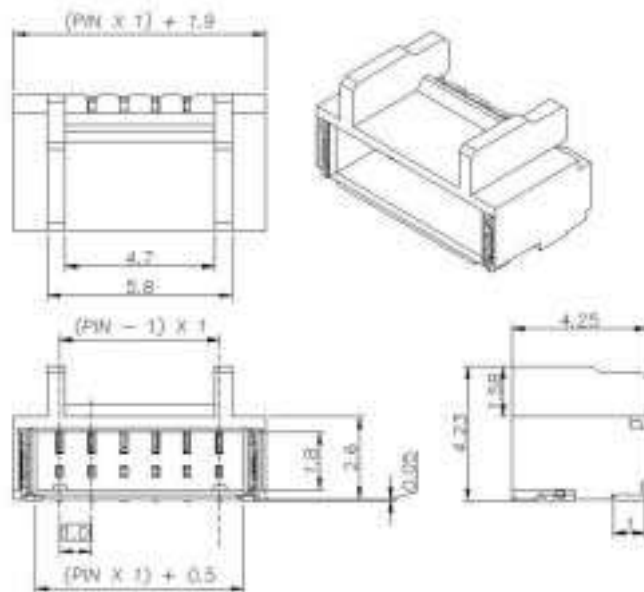

Pin number	Description
1	Cathode of LED string1
2	Cathode of LED string2
3	VLED
4	VLED
5	Cathode of LED string3
6	Cathode of LED string4

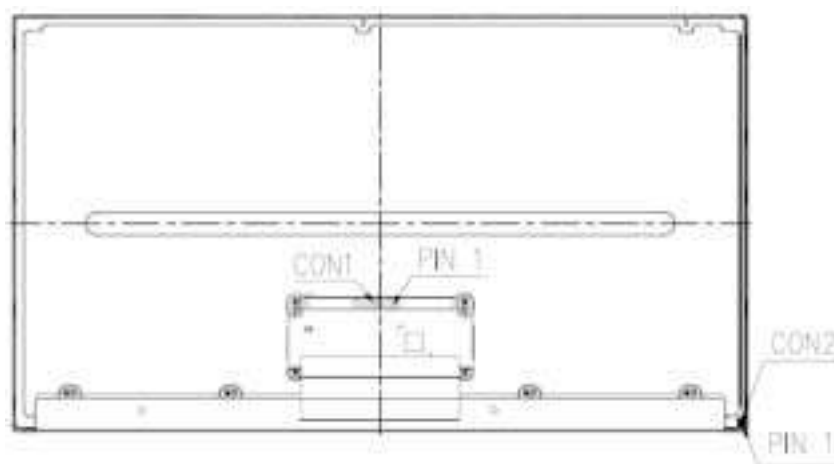

**4.4 V by One INPUT SIGNAL SPECIFICATIONS**

**4.4.1 V by One DATA MAPPING TABLE**

Lan	Data Stream
Lan 0	1, 9, 17, ....., 3825, 3833
Lan 1	2, 10, 18, ....., 3826, 3834
Lan 2	3, 11, 19, ....., 3827, 3835
Lan 3	4, 12, 20, ....., 3828, 3836
Lan 4	5, 13, 21, ....., 3829, 3837
Lan 5	6, 14, 22, ....., 3830, 3838
Lan 6	7, 15, 23, ....., 3831, 3839
Lan 7	8, 16, 24, ....., 3832, 3840



**4.4.2 COLOR DATA INPUT ASSIGNMENT**

The brightness of each primary color (red, green and blue) is based on the 10-bit gray scale data input for the color. The higher the binary input, the brighter the color. The table below provides the assignment of color versus data input.

Color		Data Signal																											
		Red										Green										BLUE							
		R9	R8	G7	G6	R5	R4	R3	R2	R1	R0	G9	G8	G7	G6	G5	G4	G3	G2	G1	G0	B9	B8	B7	B6	B5	B4	B3	B2
Basic Colors	Black	0	0	0	0	0	0	0	0	0	0	0	0	0	0	0	0	0	0	0	0	0	0	0	0	0	0	0	0
	Red	1	1	1	1	1	1	1	1	1	1	0	0	0	0	0	0	0	0	0	0	0	0	0	0	0	0	0	0
	Green	0	0	0	0	0	0	0	0	0	0	1	1	1	1	1	1	1	1	1	1	1	1	0	0	0	0	0	0
	Blue	0	0	0	0	0	0	0	0	0	0	0	0	0	0	0	0	0	0	0	1	1	1	1	1	1	1	1	1
	Cyan	0	0	0	0	0	0	0	0	0	0	1	1	1	1	1	1	1	1	1	1	1	1	1	1	1	1	1	1
	Magenta	1	1	1	1	1	1	1	1	1	1	0	0	0	0	0	0	0	0	0	1	1	1	1	1	1	1	1	1
	Yellow	1	1	1	1	1	1	1	1	1	1	1	1	1	1	1	1	1	1	1	1	1	1	1	0	0	0	0	0
White	1	1	1	1	1	1	1	1	1	1	1	1	1	1	1	1	1	1	1	1	1	1	1	1	1	1	1	1	
Gray Scale Of Red	Red(0) / Dark	0	0	0	0	0	0	0	0	0	0	0	0	0	0	0	0	0	0	0	0	0	0	0	0	0	0	0	
	Red(1)	0	0	0	0	0	0	0	0	0	1	0	0	0	0	0	0	0	0	0	0	0	0	0	0	0	0	0	
	Red(2)	0	0	0	0	0	0	0	0	1	0	0	0	0	0	0	0	0	0	0	0	0	0	0	0	0	0	0	
	⋮	⋮	⋮	⋮	⋮	⋮	⋮	⋮	⋮	⋮	⋮	⋮	⋮	⋮	⋮	⋮	⋮	⋮	⋮	⋮	⋮	⋮	⋮	⋮	⋮	⋮	⋮		
	⋮	⋮	⋮	⋮	⋮	⋮	⋮	⋮	⋮	⋮	⋮	⋮	⋮	⋮	⋮	⋮	⋮	⋮	⋮	⋮	⋮	⋮	⋮	⋮	⋮	⋮	⋮		
	Red(1021)	1	1	1	1	1	1	1	1	0	1	0	0	0	0	0	0	0	0	0	0	0	0	0	0	0	0	0	
	Red(1022)	1	1	1	1	1	1	1	1	1	0	0	0	0	0	0	0	0	0	0	0	0	0	0	0	0	0	0	
Red(1023)	1	1	1	1	1	1	1	1	1	1	0	0	0	0	0	0	0	0	0	0	0	0	0	0	0	0	0		
Gray Scale Of Green	Green(0) / Dark	0	0	0	0	0	0	0	0	0	0	0	0	0	0	0	0	0	0	0	0	0	0	0	0	0	0	0	
	Green(1)	0	0	0	0	0	0	0	0	0	0	0	0	0	0	0	0	0	1	0	0	0	0	0	0	0	0		
	Green(2)	0	0	0	0	0	0	0	0	0	0	0	0	0	0	0	0	0	1	0	0	0	0	0	0	0	0		
	⋮	⋮	⋮	⋮	⋮	⋮	⋮	⋮	⋮	⋮	⋮	⋮	⋮	⋮	⋮	⋮	⋮	⋮	⋮	⋮	⋮	⋮	⋮	⋮	⋮	⋮			
	⋮	⋮	⋮	⋮	⋮	⋮	⋮	⋮	⋮	⋮	⋮	⋮	⋮	⋮	⋮	⋮	⋮	⋮	⋮	⋮	⋮	⋮	⋮	⋮	⋮	⋮			
	Green(1021)	0	0	0	0	0	0	0	0	0	1	1	1	1	1	1	1	1	0	1	0	0	0	0	0	0	0		
	Green(1022)	0	0	0	0	0	0	0	0	0	1	1	1	1	1	1	1	1	1	0	0	0	0	0	0	0	0		
Green(1023)	0	0	0	0	0	0	0	0	0	1	1	1	1	1	1	1	1	1	1	0	0	0	0	0	0	0			
Gray Scale Of Blue	Blue(0) / Dark	0	0	0	0	0	0	0	0	0	0	0	0	0	0	0	0	0	0	0	0	0	0	0	0	0	0	0	
	Blue(1)	0	0	0	0	0	0	0	0	0	0	0	0	0	0	0	0	0	0	0	0	0	0	0	0	0	1		
	Blue(2)	0	0	0	0	0	0	0	0	0	0	0	0	0	0	0	0	0	0	0	0	0	0	0	0	0	1		
	⋮	⋮	⋮	⋮	⋮	⋮	⋮	⋮	⋮	⋮	⋮	⋮	⋮	⋮	⋮	⋮	⋮	⋮	⋮	⋮	⋮	⋮	⋮	⋮	⋮	⋮			
	⋮	⋮	⋮	⋮	⋮	⋮	⋮	⋮	⋮	⋮	⋮	⋮	⋮	⋮	⋮	⋮	⋮	⋮	⋮	⋮	⋮	⋮	⋮	⋮	⋮	⋮			
	Blue(1021)	0	0	0	0	0	0	0	0	0	0	0	0	0	0	0	0	0	0	1	1	1	1	1	1	1	1		
	Blue(1022)	0	0	0	0	0	0	0	0	0	0	0	0	0	0	0	0	0	0	1	1	1	1	1	1	1	1		
Blue(1023)	0	0	0	0	0	0	0	0	0	0	0	0	0	0	0	0	0	0	1	1	1	1	1	1	1	1			

Note (1) 0: Low Level Voltage, 1: High Level Voltage

**4.5 DISPLAY TIMING SPECIFICATIONS**

The input signal timing specifications are shown as the following table and timing diagram.

Signal	Item	Symbol	Min.	Typ.	Max.	Unit	Note
V by One	Frequency	Fc	70	74.25	80	MHz	(1)
	Intra-Pair skew		-0.3	-	0.3	UI	(2)
	Inter-Pair skew		-5	-	5	UI	(3)
	Spread spectrum modulation range	Fclkin_mod	F <sub>clkin</sub> -0.5%	-	F <sub>clkin</sub> +0.5%	MHz	(4)
	Spread spectrum modulation frequency	F <sub>SSM</sub>	-	-	30	KHz	
Vertical Display Term	Frame Rate	Fr	57.5	60	62.5	Hz	(5)(6)
	Total	Tv	2200	2250	2790	Th	Tv=Tvd+Tvb
	Active Display	Tvd	2160	2160	2160	Th	-
	Blank	Tvb	40	90	630	Th	-
Horizontal Display Term	Total	Th	530	550	570	Tc	Th=Thd+Thb
	Active Display	Thd	480	480	480	Tc	-
	Blank	Thb	50	70	90	Tc	-

Note (1) Please make sure the range of pixel clock has follow the below equation:

$$F_{clkin(max)} = \frac{Fr}{Tv} \cdot Th$$

$$Fr = \frac{Tv}{Th} \cdot F_{clkin(min)}$$

INPUT SIGNAL TIMING DIAGRAM

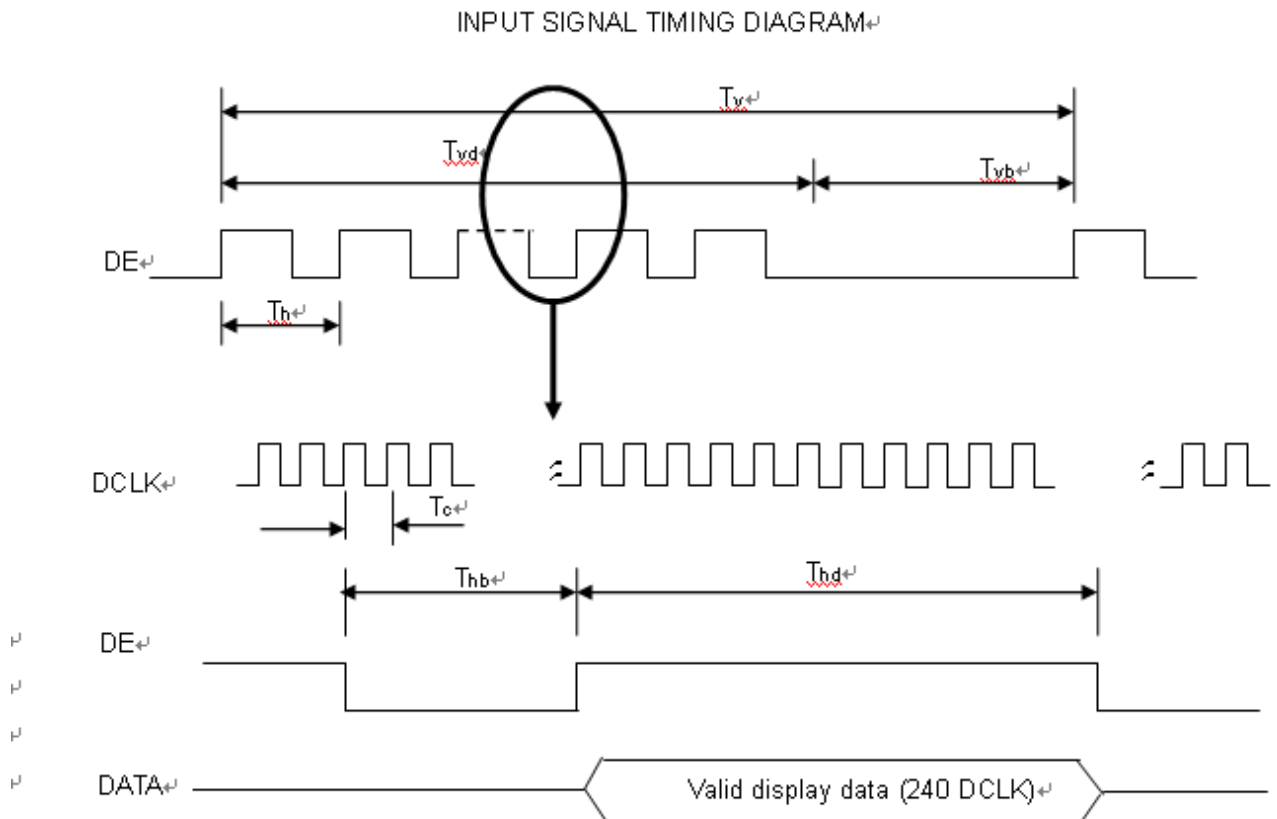

Note (2) V-by-One HS Intra-pair skew

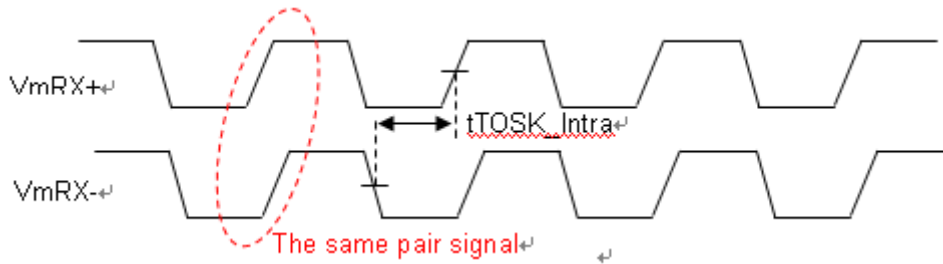

Note (3) V-by-One HS Inter-pair skew

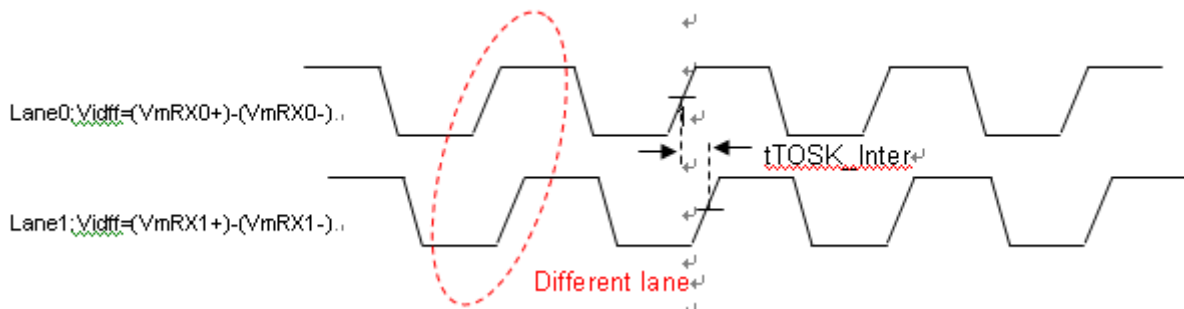

Note (4) The SSCG (Spread spectrum clock generator) is defined as below figures.

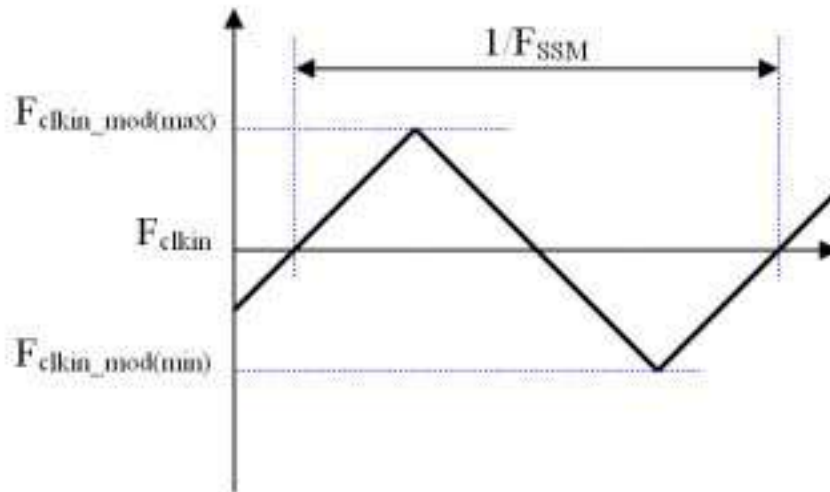

Note (5) The frame-to-frame jitter of the input frame rate is defined as the above figures.  $FR_n = FR_{n-1} \pm 0.5\%$ .

Note (6) The setup of the frame rate jitter > 0.5% may result in the cosmetic LED backlight symptom and the electric function is affected.

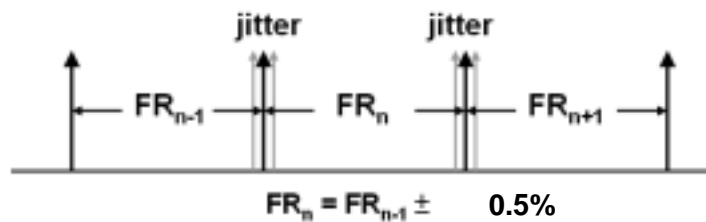

4.6 V by One Input Signal Timing Diagram

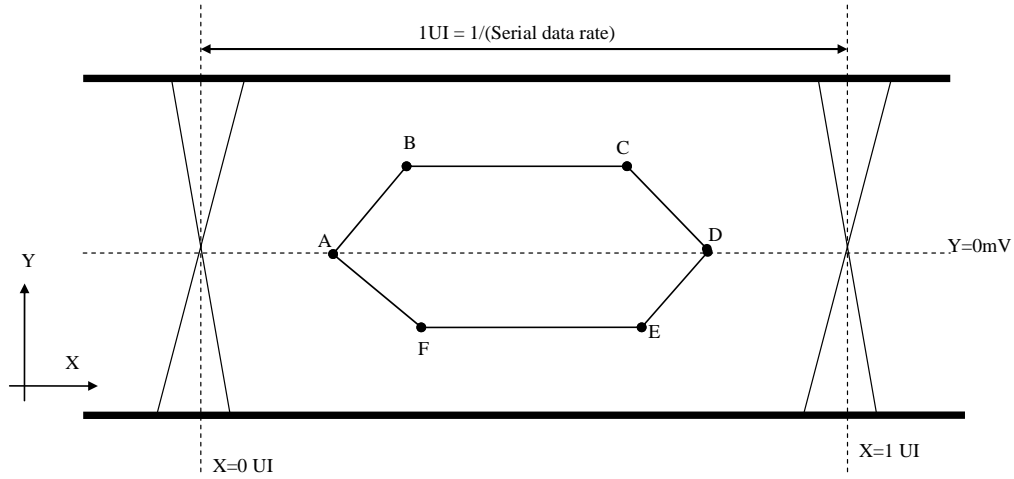

Table 1 Eye Mask Specification

	X [UI]	Y [mV]	Note
A	0.25	0	(1)
B	0.3	50	(1)
C	0.7	50	(1)
D	0.75	0	(1)
E	0.7	-50	(1)
F	0.3	-50	(1)

Note (1) Input levels of V-by-One HS signals are comes from "V-by-One HS Stander Ver.1.4"

**4.7 Byte Length and Color mapping of V-by-One HS**

Packer input & Unpacker output		30bpp RGB (10bit)
Byte 0	D[0]	R[2]
	D[1]	R[3]
	D[2]	R[4]
	D[3]	R[5]
	D[4]	R[6]
	D[5]	R[7]
	D[6]	R[8]
	D[7]	R[9]
Byte 1	D[8]	G[2]
	D[9]	G[3]
	D[10]	G[4]
	D[11]	G[5]
	D[12]	G[6]
	D[13]	G[7]
	D[14]	G[8]
	D[15]	G[9]
Byte 2	D[16]	B[2]
	D[17]	B[3]
	D[18]	B[4]
	D[19]	B[5]
	D[20]	B[6]
	D[21]	B[7]
	D[22]	B[8]
	D[23]	B[9]
Byte 3	D[24]	X
	D[25]	X
	D[26]	B[0]
	D[27]	B[1]
	D[28]	G[0]
	D[29]	G[1]
	D[30]	R[0]
	D[31]	R[1]

**4.8 POWER ON/OFF SEQUENCE**

( $T_a = 25 \pm 2 \text{ }^\circ\text{C}$ )

To prevent a latch-up or DC operation of LCD module, the power on/off sequence should be as the diagram below.

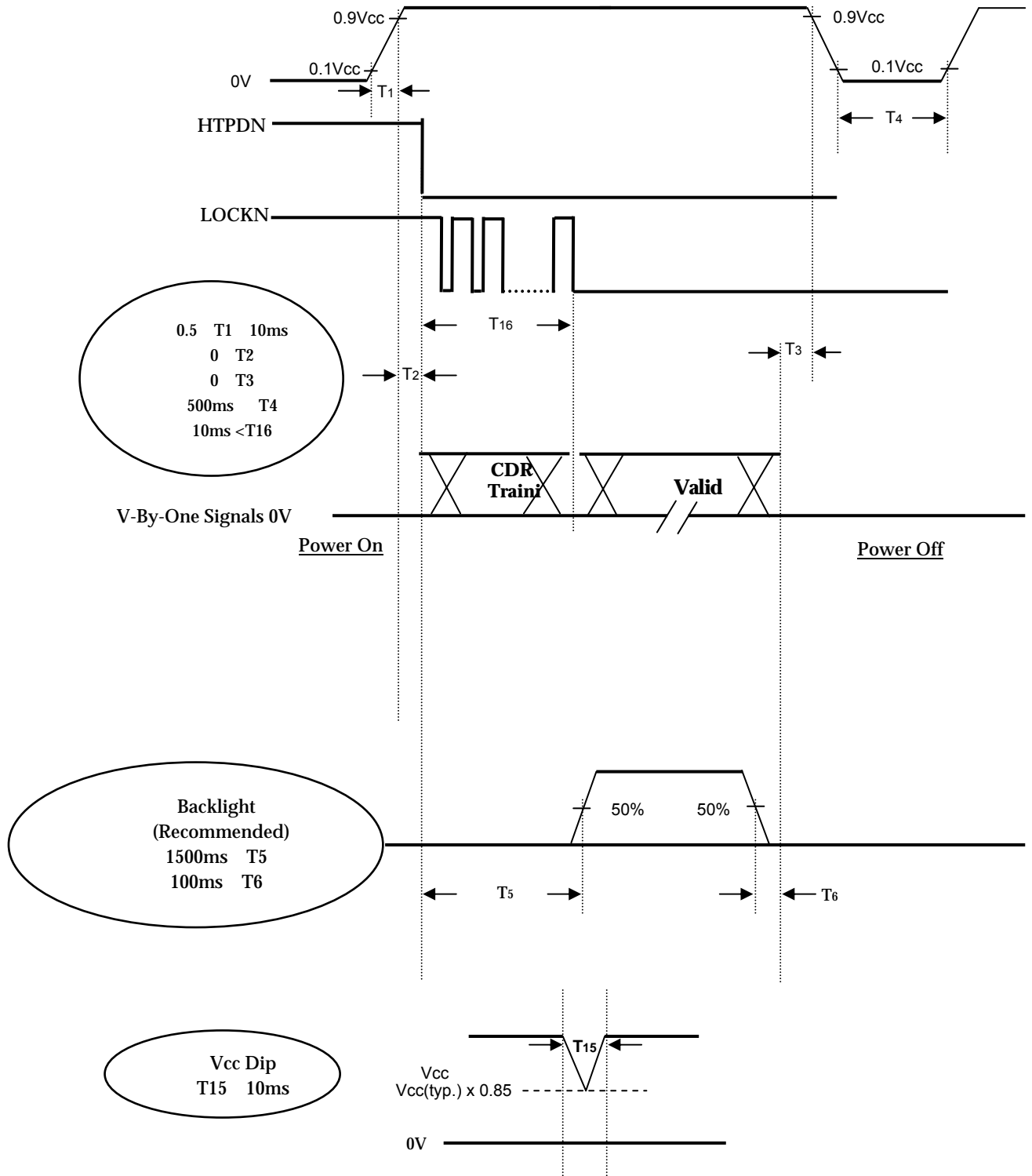

Note (1) The supply voltage of the external system for the module input should follow the definition of Vcc.

Note (2) Apply the LED voltage within the LCD operation range. When the backlight turns on before the LCD operation or the LCD turns off before the backlight turns off, the display may momentarily become abnormal screen..

Note (3) In case of Vcc is in off level, please keep the level of input signals on the low or high impedance. If  $T2 < 0$ , that maybe cause electrical overstress failure.

Note (4) T4 should be measured after the module has been fully discharged between power off and on period..

Note (5) Interface signal shall not be kept at high impedance when the power is on

Note (6) Vcc must decay smoothly when power-off

## 5. OPTICAL CHARACTERISTICS

### 5.1 TEST CONDITIONS

Item	Symbol	Value	Unit
Ambient Temperature	Ta	25±2	oC
Ambient Humidity	Ha	50±10	%RH
Supply Voltage	VCC	12±0.12	V
Input Signal	According to typical value in "3. ELECTRICAL CHARACTERISTICS"		
LED Light Bar Input Current Per Input Pin	IPIN	150	mA
PWM Duty Ratio	D	100	%
LED Light Bar Test Converter	(INX 27 - D089583)		

### 5.2 OPTICAL SPECIFICATIONS

The relative measurement methods of optical characteristics are shown in 5.2. The following items should be measured under the test conditions described in 5.1 and stable environment shown in Note (5).

Item	Symbol	Condition	Min.	Typ.	Max.	Unit	Note	
Color Chromaticity (CIE 1931)	Red	Rx	$\theta_x=0^\circ, \theta_y=0^\circ$ CS-2000 R=G=B=255 Gray scale	Typ – 0.03	0.633	Typ + 0.03	-	(1), (5)
		Ry			0.340			
	Green	Gx			0.311			
		Gy			0.633			
	Blue	Bx			0.158			
		By			0.061			
	White	Wx			0.313			
		Wy			0.329			
Center Luminance of White (Center of Screen)	L <sub>c</sub>		250	300	-	cd/m <sup>2</sup>	(4), (5)	
Contrast Ratio	CR		700	1000	-	-	(2), (5)	
Response Time	T <sub>R</sub>	$\theta_x=0^\circ, \theta_y=0^\circ$	-	1.5	2.5	ms	(3)	
	T <sub>F</sub>		-	3.5	5.5			
White Variation	W	$\theta_x=0^\circ, \theta_y=0^\circ$	--	-	1.42	--	(5), (6)	
Viewing Angle	Horizontal	$\theta_x- + \theta_x+$	CR 10	150	170	-	Deg.	(1), (5)
	Vertical	$\theta_y- + \theta_y+$		140	160	-		



Note (1) Definition of Viewing Angle ( $\theta_x, \theta_y$ ):

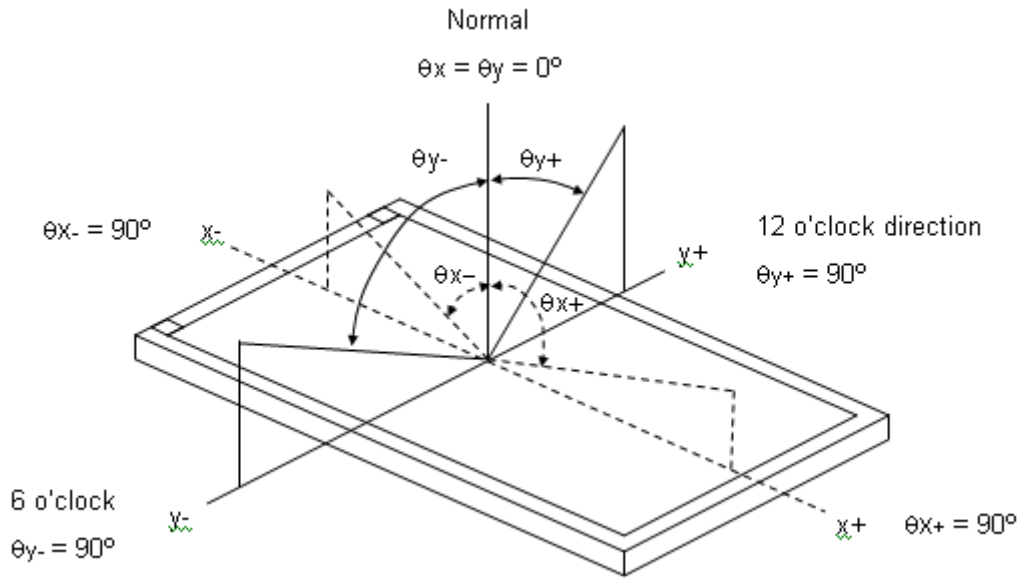

Note (2) Definition of Contrast Ratio (CR):

The contrast ratio can be calculated by the following expression.

$$\text{Contrast Ratio (CR)} = L_{255} / L_0$$

L255: Luminance of gray level 255

L 0: Luminance of gray level 0

$$\text{CR} = \text{CR} (5)$$

CR (X) is corresponding to the Contrast Ratio of the point X at Figure in Note (6).

Note (3) Definition of Response Time ( $T_R, T_F$ ):

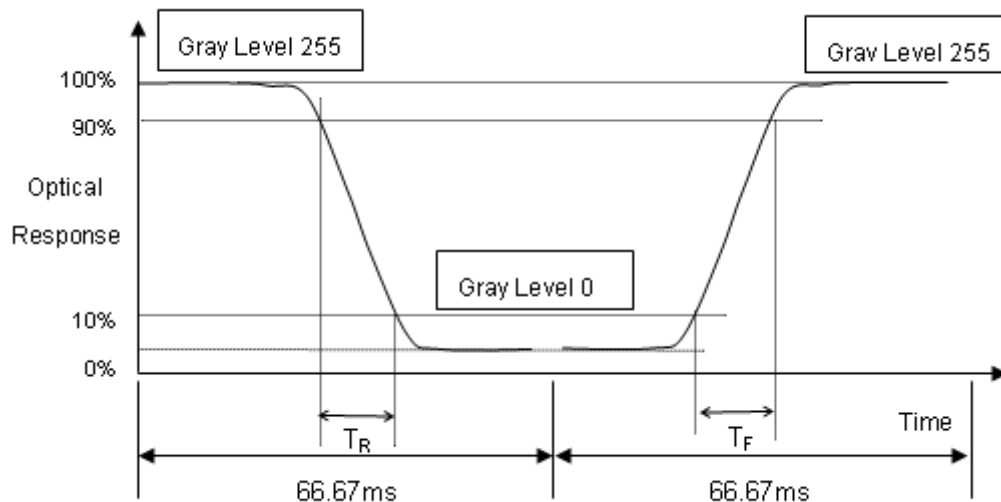

Note (4) Definition of Luminance of White ( $L_c$ ):

Measure the luminance of gray level 255 at center point

$$L_c = L(5)$$

$L(x)$  is corresponding to the luminance of the point X at Figure in Note (6).

Note (5) Measurement Setup:

The LCD module should be stabilized at given temperature for 40 minutes to avoid abrupt temperature change during measuring. In order to stabilize the luminance, the measurement should be executed after lighting Backlight for 40 minutes in a windless room.

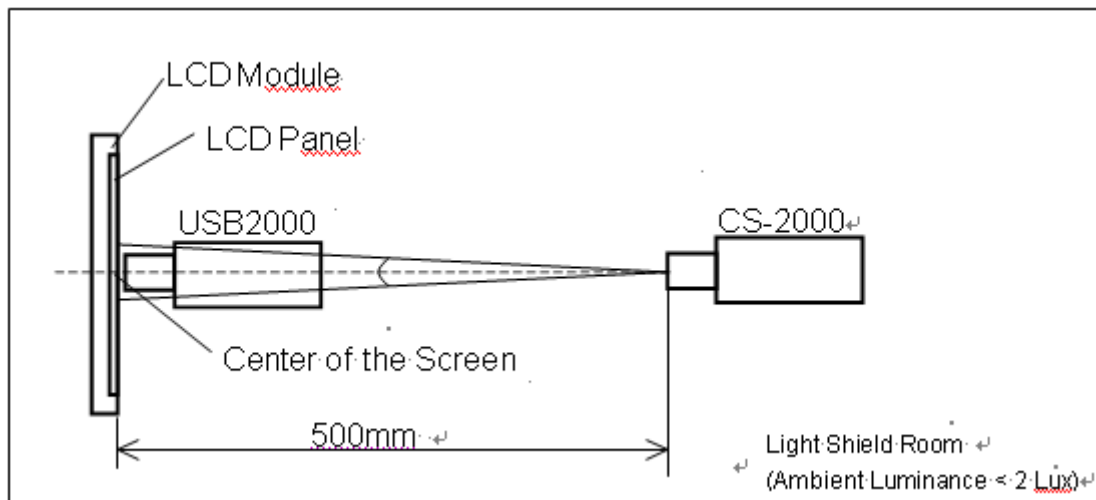

Note (6) Definition of White Variation ( $\delta W$ ):

Measure the luminance of gray level 255 at 9 points

$$\delta W = \text{Maximum} [L(1) \sim L(9)] / \text{Minimum} [L(1) \sim L(9)]$$

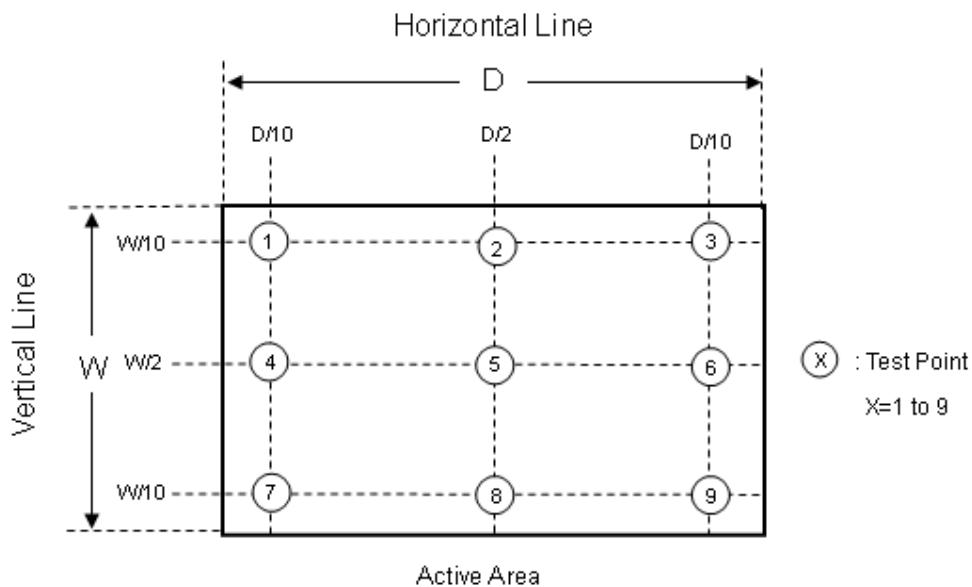

**6. RELIABILITY TEST ITEM**

Items	Required Condition	Note
Temperature Humidity Bias (THB)	Ta= 50 , 80%RH, 240hours	
High Temperature Operation (HTO)	Ta= 50 , 240hours	
Low Temperature Operation (LTO)	Ta= 0 , 240hours	
High Temperature Storage (HTS)	Ta= 60 , 240hours	
Low Temperature Storage (LTS)	Ta= -20 , 240hours	
Vibration Test (Non-operation)	Acceleration: 1.5 G Wave: sine Frequency: 10 - 300 Hz Sweep: 30 Minutes each Axis (X, Y, Z)	
Shock Test (Non-operation)	Acceleration: 50 G Wave: Half-sine Active Time: 11 ms Direction : ± X, ± Y, ± Z.(one time for each Axis)	
Thermal Shock Test (TST)	-20 /30min , 60 / 30min , 100 cycles	
On/Off Test	25 ,On/10sec , Off /10sec , 30,000 cycles	
ESD (Electro Static Discharge)	Contact Discharge: ± 8KV, 150pF(330Ω)	
	Air Discharge: ± 15KV, 150pF(330Ω)	
Altitude Test	Operation:10,000 ft / 24hours Non-Operation:30,000 ft / 24hours	

Note (1) criteria : Normal display image with no obvious non-uniformity and no line defect.

Note (2) Evaluation should be tested after storage at room temperature for more than two hour

Note (3) At testing Vibration and Shock, the fixture in holding the module has to be hard and rigid enough so that the module would not be twisted or bent by the fixture.

The fixing condition is shown as below:

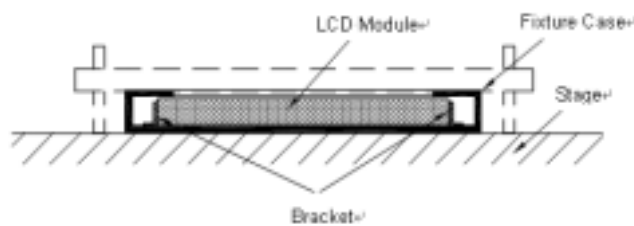

## 7. Mechanical Strength Characteristics

### 7.1 Mechanical Strength Specifications

Item	Condition	Min	Unit	Note
Mechanical Strength	128 <sup>th</sup> Gray Pattern	0.6	Kgf	

### 7.2 Test Conditions

Items	Description
Test Condition	<ol style="list-style-type: none"> <li>1. Ambient Illumination : 10~15 lux</li> <li>2. Test Pattern : 128 Gray</li> <li>3. Distance of the judgment : 30cm from the surface of module</li> <li>4. Viewing angle of the judgment : Front</li> </ol>
Gage Information	<ol style="list-style-type: none"> <li>1. Push pull guage               <ol style="list-style-type: none"> <li>a. Model name : HF-50, maker : ALGOL</li> <li>b. Shape of gage tip                   <ul style="list-style-type: none"> <li>- Diameter : 2mm</li> <li>- Thickness : 2mm</li> </ul> </li> </ol> </li> </ol>
Definition of Minimum force	To measure minimum force when operator detects any white spot and light leakage that have occurred while operator presses on back side of module with push pull gage.

### 7.3 Definition of Test Points

Measure the minimum force of test points at 128th Gray pattern. The test points at back side of module area is showing as below (except PCBA).

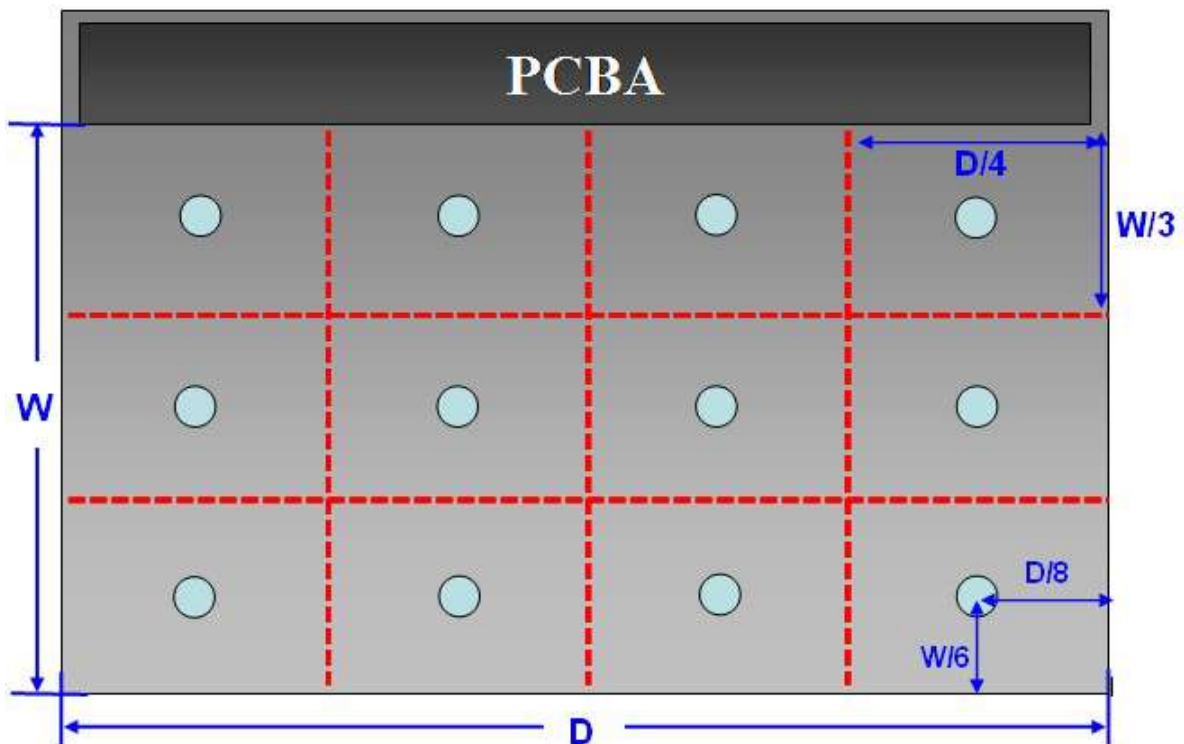

## 8. PACKING

### 8.1 PACKING SPECIFICATIONS

- (1) 9 LCD modules / 1 Box
- (2) Box dimensions: 713(L) X 429(W) X 453(H) mm
- (3) Weight: approximately: (34) Kg ( 9 modules per box)

### 8.2 PACKING METHOD

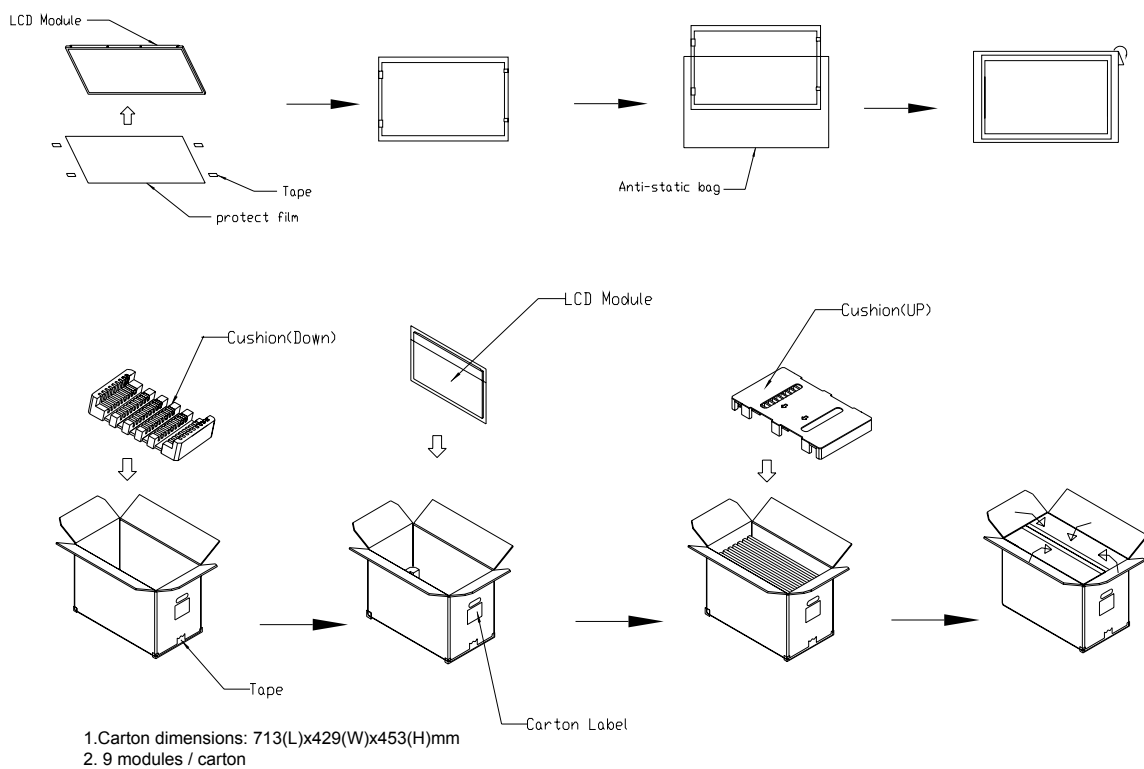
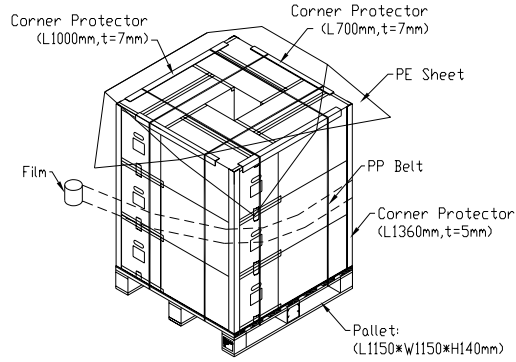

Figure. 8-1 Packing method

**8.3 PALLET**

For ocean shipping

**Air Transportation**



For air transport

**Sea / Land Transportation  
(40ft HQ Container)**

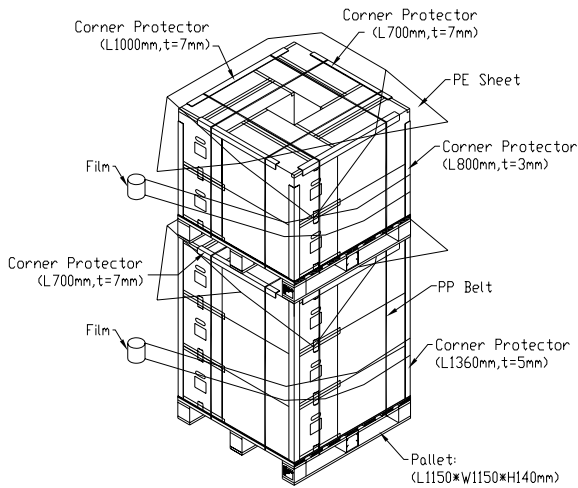

**Sea / Land Transportation  
(40ft Container)**

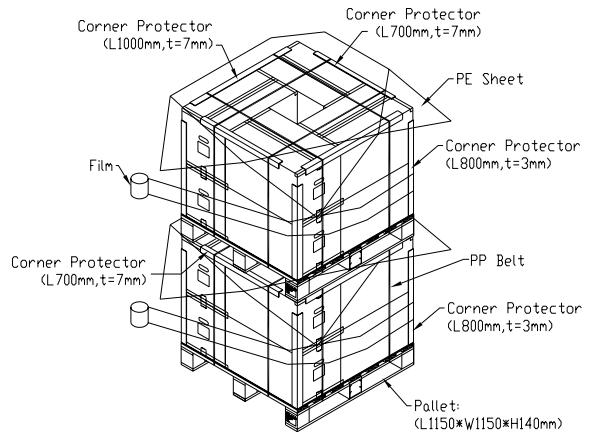

Figure. 8-2 Packing method

**8.4 UN-PACKING METHOD**

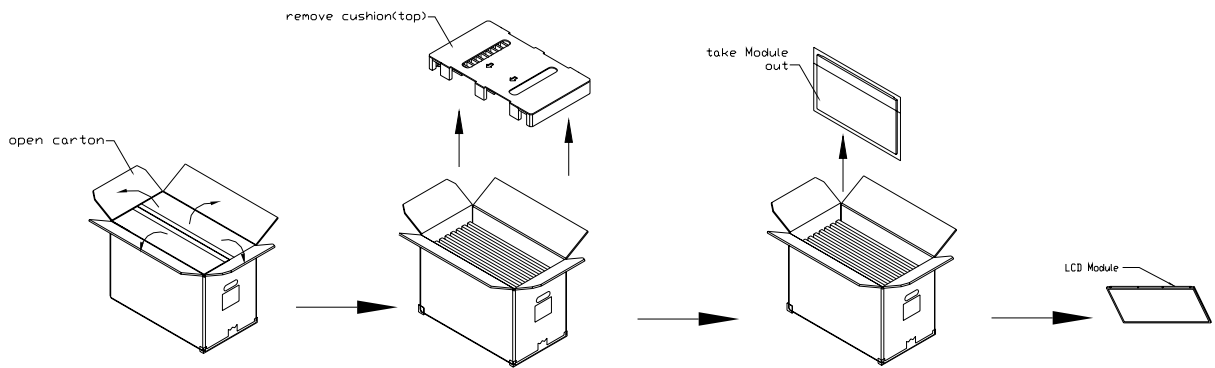

Figure. 8-3 UN-Packing method

## 9. INX MODULE LABEL

The barcode nameplate is pasted on each module as illustration, and its definitions are as following explanation.



(a) Model Name: M280DGJ-L30

(b) Revision: Rev. XX, for example: A0, A1... B1, B2... or C1, C2...etc.

(c) InnoLux barcode definition:

Serial ID: XX-XX-X-XX-YMD-L-NNNN

Code	Meaning	Description
XX	InnoLux internal use	-
XX	Revision	Cover all the change
X	InnoLux internal use	-
XX	InnoLux internal use	-
YMD	Year, month, day	Year: 0~9, 2001=1, 2002=2, 2003=3...2010=0, 2011=1, 2012=2... Month: 1~12=1, 2, 3, ~, 9, A, B, C Day: 1~31=1, 2, 3, ~, 9, A, B, C, ~, W, X, Y, exclude I, O, and U.
L	Product line #	Line 1=1, Line 2=2, Line 3=3, ...
NNNN	Serial number	Manufacturing sequence of product

(d) Customer's barcode definition:

Serial ID: CM-S0J03-X-X-X-XX-L-XX-L-YMD-NNNN

Code	Meaning	Description
CM	Supplier code	INX=CM
S0J03	Model number	M280DGJ-L30= S0J03
X	Revision code	Non ZBD: 1,2,~,8,9 / ZBD: A~Z
X	Source driver IC code	Century=1, CLL=2, Demos=3, Epson=4, Fujitsu=5, Himax=6, Hitachi=7, Hynix=8, LDI=9, Matsushita=A, NEC=B, Novatec=C, OKI=D, Philips=E, Renesas=F, Samsung=G, Sanyo=H, Sharp=I, TI=J, Topro=K, Toshiba=L, Windbond=M, ILITEK=Q, Fiti=Y, None IC =Z
X	Gate driver IC code	OKI=D, Philips=E, Renesas=F, Samsung=G, Sanyo=H, Sharp=I, TI=J, Topro=K, Toshiba=L, Windbond=M, ILITEK=Q, Fiti=Y, None IC =Z
XX	Cell location	Tainan Taiwan=TN, Ningbo China=CN, Hsinchu Taiwan=SC
L	Cell line #	1,2,~,9,A,B,~,Y,Z
XX	Module location	Tainan, Taiwan=TN, Ningbo China=NP, Shenzhen China=SH, Nanhai China=NH
L	Module line #	1,2,~,9,A,B,~,Y,Z
YMD	Year, month, day	Year: 0~9, 2001=1, 2002=2, 2003=3...2010=0, 2011=1, 2012=2... Month: 1~12=1, 2, 3, ~, 9, A, B, C Day: 1~31=1, 2, 3, ~, 9, A, B, C, ~, T, U, V
NNNN	Serial number	By LCD supplier



(e) FAB ID(UL Factory ID):

Region	Factory ID
TWINX	GEMN
NBCMI	LEOO
NBCMI	VIRO
NBCME	CANO
NHCMI	CAPG

## 10. PRECAUTIONS

### 10.1 ASSEMBLY AND HANDLING PRECAUTIONS

- (1) Do not apply rough force such as bending or twisting to the module during assembly.
- (2) To assemble or install module into user's system can be only in clean working areas. The dust and oil may cause electrical short or worsen the polarizer.
- (3) It's not permitted to have pressure or impulse on the module because the LCD panel and Backlight will be damaged.
- (4) Always follow the correct power sequence when LCD module is connecting and operating. This can prevent damage to the CMOS LSI chips during latch-up.
- (5) Do not pull the I/F connector in or out while the module is operating.
- (6) Do not disassemble the module.
- (7) Use a soft dry cloth without chemicals for cleaning, because the surface of polarizer is very soft and easily scratched.
- (8) It is dangerous that moisture come into or contacted the LCD module, because moisture may damage LCD module when it is operating.
- (9) High temperature or humidity may reduce the performance of module. Please store LCD module within the specified storage conditions.
- (10) When ambient temperature is lower than 10°C may reduce the display quality. For example, the response time will become slowly.

### 10.2 STORAGE PRECAUTIONS

- (1) Do not leave the module in high temperature, and high humidity for a long time. It is highly recommended to store the module with temperature from 0 to 35 and relative humidity of less than 90%
- (2) Do not store the TFT – LCD module in direct sunlight
- (3) The module should be stored in dark place. It is prohibited to apply sunlight or fluorescent light in storing

### 10.3 OPERATION PRECAUTIONS

(1) The LCD product should be operated under normal condition.

Normal condition is defined as below :

Temperature : 20±15

Humidity: 65±20%

Display pattern : continually changing pattern(Not stationary)

(2) If the product will be used in extreme conditions such as high temperature, high humidity, high altitude ,display pattern or operation time etc...It is strongly recommended to contact INX for application engineering advice . Otherwise , Its reliability and function may not be guaranteed.

### 10.4 SAFETY PRECAUTIONS

(1) If the liquid crystal material leaks from the panel, it should be kept away from the eyes or mouth. In case of contact with hands, skin or clothes, it has to be washed away thoroughly with soap.

(2) After the module's end of life, it is not harmful in case of normal operation and storage.

### 10.5 SAFETY STANDARDS



The LCD module should be certified with safety regulations as follows:

Requirement	Standard	remark
UL	UL60950-1:2006 or Ed.2:2007	
cUL/CSA	CAN/CSA C22.2 No.60950-1-03 or 60950-1-07	
CB	IEC60950-1:2005 / EN60950-1:2006+ A11:2009	

### 10.6 OTHER

When fixed patterns are displayed for a long time, remnant image is likely to occur.

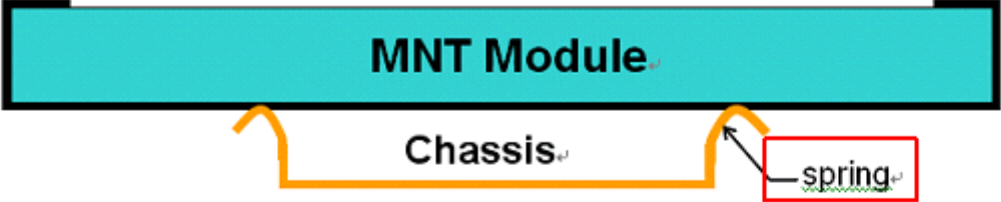
Appendix 1. SYSTEM COVER DESIGN NOTICE

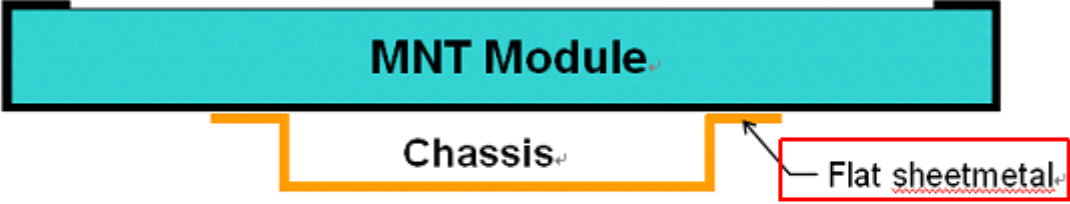
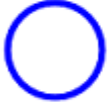
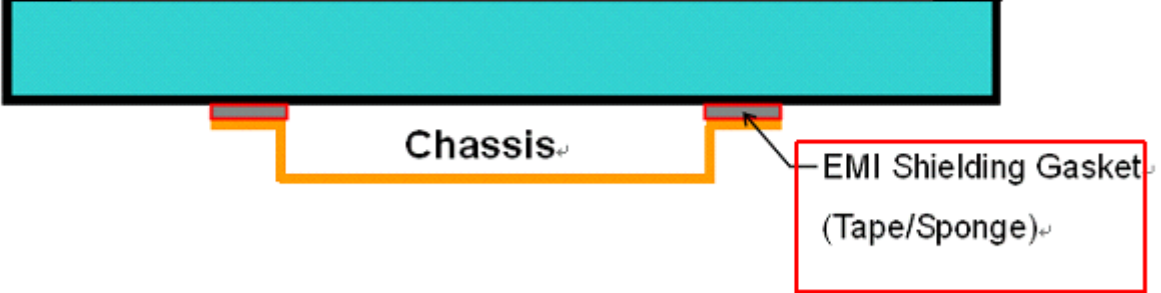
1.	Set Chassis and MNT Module touching Mode
	
	
	
<p>Definition</p>	<p>a) To prevent from abnormal display &amp; white spot after Mechanical test, it is not recommended to used <u>spring</u> type chassis.</p> <p>b) We suggest the contact mode between Chassis and Module rear cover is <u>Tape/Sponge</u>, second is <u>Flat sheetmetal</u> type chassis (Don't interference from flat sheetmetal of chassis to rear cover of <u>Module</u>).</p>

2	Tape/sponge design on system inner surface
Definition	<p>a) To prevent from abnormal display &amp; white spot after Mechanical test, We suggest using Tape/Sponge as medium between chassis and Module rear cover could reduce the occurrence of white spot.</p> <p>b) When using the Tape/Sponge, suggest it be lay over between set chassis and module rear cover. it is not recommended to add tape/sponge in separate location. Since each tape/sponge may act as pressure concentration location.</p>

3	<b>System inner surface examination</b>
Definition	<p>a). Burr at logo edge, step, protrusion or PCB board will easily cause white spot.</p> <p>b). Keeping flat surface underneath module is recommended.</p> <p>c). The area (  ) on Module PCBA and Light bar connector should keep at least 1mm gap to any structure with System cover inner surface.</p>



REV	EC NUMBER	DESCRIPTION	DATE
1		First Release	2015/04/03
2	U0066202	Modify Rev	2016/06/11

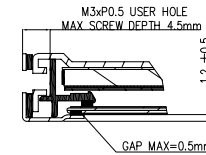
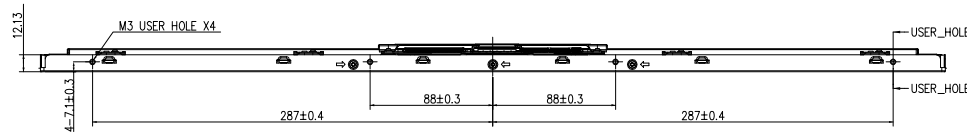
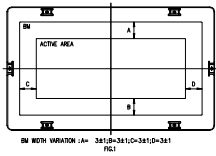

SECTION USER\_HOLE-USER\_HOLE  
SCALE 4:1

Scan COF Position  
(SI mechanical structure should not touch the positions of Data COF)

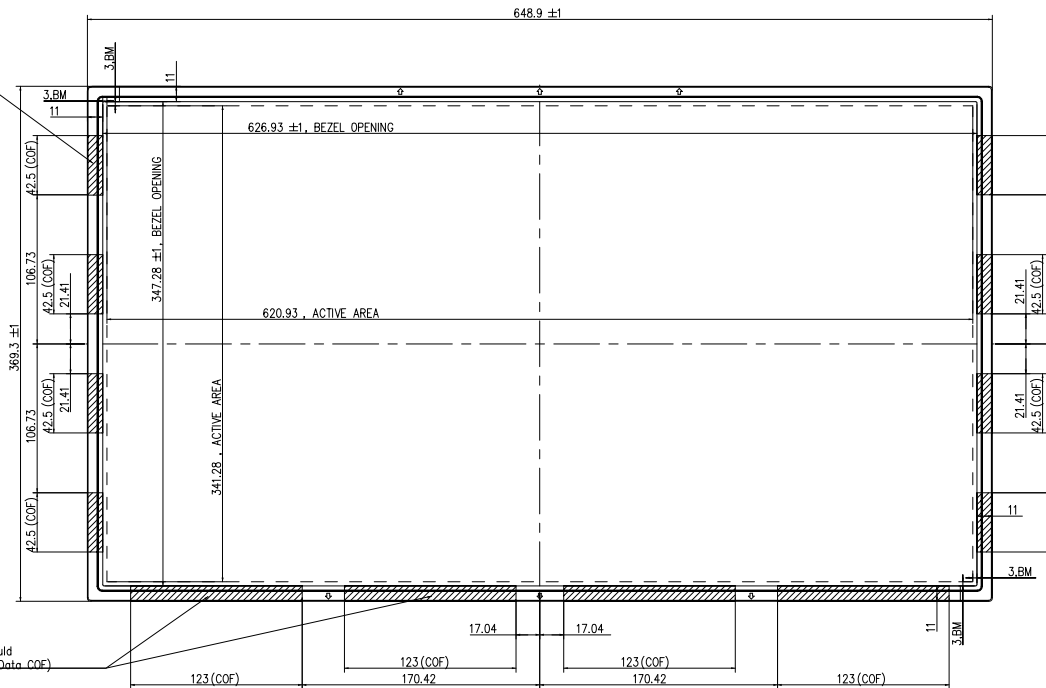

Data COF Position  
(SI mechanical structure should not touch the positions of Data COF)

19.85 , Ctrl Cover

16.43 , PCB-X Cover

- NOTES:
- UNLESS OTHERWISE SPECIFY TOLERANCE IS ±1.0mm.
  - Scan COF position (SI mechanical structure should not touch the positions of Data COF)
  - CONNECTOR TYPE:  
CON\_1: FCN WF23-402-5133 or P-TWO 187059-51221, OR EQUIVALENT  
CON\_2: FCN WM13-406-063N, or Civlux CH406M1HRK-NH, OR EQUIVALENT
  - SCREW HOLES TYPE:  
M3-PITCH 0.5 / MACHINE, MAX. TORQUE=5 KGF-CM, MAX.DEPTH=4.5mm
  - System integration company must keep module up and down direction on the drawing to design set

drawing to design set

APPROVED	CHECKED	DESIGNED	DATE	SCALE	UNIT	FIG. NO.	TOTAL FIG.
Hans Liu	Gary Sung	Colin Guo	2016/06/11	1:1	MM	DN0349213	8
						module_M28000J-L30	1/2

REV	CC NUMBER	DESCRIPTION	DATE
▲		First Release	2023/04/23
▲	CHANGE	Modify Rev	2024/05/11

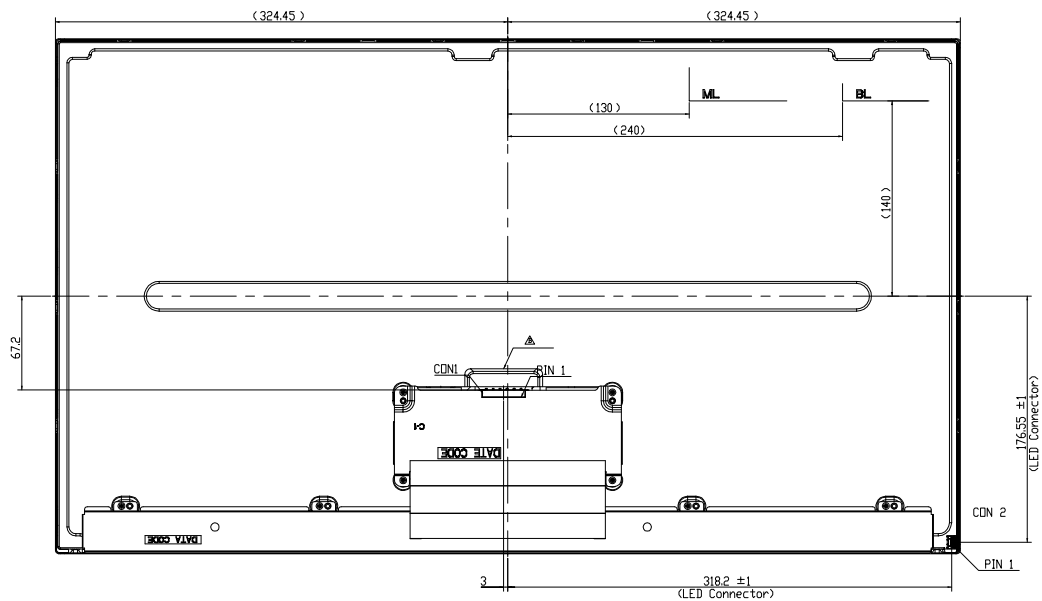

- NOTES:
- UNLESS OTHERWISE SPECIFY TOLERANCE IS ±1.0mm.
  - CONNECTOR TYPE:  
 CON\_1: FCN WF23-400-513C or P-TWD 187059-51221, OR EQUIVALENT  
 CON\_2: FCN WM13-406-063N, or Civlux CI1406MHRK-NH, OR EQUIVALENT
  - SCREW HOLES TYPE:  
 M3PITCH 0.5 / MACHINE, MAX. TORQUE=5 KGF-CM, MAX.DEPH=4.5mm
  - ☒: SUGGESTED MOUNTING AREA POSITION, NO MARK AREA CAN'T BE CLIPPED
  - The wire and FFC cables of the system integration company can't overlap the screw holes of the rearcover

DIMENSIONAL TOLERANCE							
RANGE(mm)	0~6	6~30	30~150	150~300	300~600	600~1000	>1000
TOL. ±	±0.1	±0.15	±0.2	±0.25	±0.3	±0.4	±0.5

APPROVED	Hens Liu	DATE	SCALE	PROJ	INSTRUMENT
CHECKED	Gary sung	REV	1:1	IN0349213	3
DESIGNED	Collin Guo	REV		module_M2805GJ-L30	2/2
				<b>INNOVATION</b>	AL+