



Product Specification

AUO-General

G215HAN01.2(201)

AU OPTRONICS CORPORATION

() Preliminary Specification

(V) Final Specification

Module	21.5" Color TFT-LCD
Model Name	G215HAN01.2 (97.21G03.201)

Customer	Date
_____	_____
Approved by	
_____	_____

Approved by	Date
<u>Flossie Chuang</u>	<u>2021/10/01</u>
Prepared by	
<u>Roxanne Lin</u>	<u>2021/10/01</u>



Note: This Specification is subject to change without notice.

General Display Business Division /
AU Optronics corporation

Contents

1.0 Handling Precautions	4
2.0 General Description	5
2.1 Display Characteristics.....	5
2.2 Optical Characteristics	6
3.0 Functional Block Diagram	10
4.0 Absolute Maximum Ratings	11
4.1 TFT LCD Module.....	11
4.2 Absolute Ratings of Environment	11
5.0 Electrical characteristics	11
5.1 TFT LCD Module.....	11
5.2 Backlight Unit.....	14
6.0 Signal Characteristic	15
6.1 Pixel Format Image	15
6.2 The input data format	16
6.3 Signal Description	17
6.4 Timing Characteristics.....	19
6.5 Timing diagram.....	20
6.6 Power ON/OFF Sequence	21
7.0 Connector & Pin Assignment	22
7.1 TFT LCD Module.....	22
7.2 LED Backlight Unit: LED Connector.....	23
7.3 LED Connector Pin Assignment.....	23
8.0 Reliability Test	24
9.0 Shipping Label & Packaging	25
9.1 Shipping Label	25
9.2 Packaging	26
9.3 Palletizing.....	26
10.0 Mechanical Characteristics	27
11 Safety	29
11.1 Sharp Edge Requirements	29
11.2 Materials.....	29
11.3 Capacitors	29
11.4 National Test Lab Requirement	29

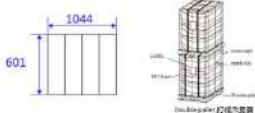
Record of Revision

Version	Date	Page	Old description	New Description																		
0.1	2018/8/8	All		First draft specification																		
1.0	2019/1/11	1	First draft specification	Final Specification																		
1.1	2019/2/18	5	Operating 0~50 °C	Operating 0~60 °C																		
		25	<p>Max capacity : 8 TFT-LCD module per carton. Max weight: 18.0 kg per carton. Outside dimension of carton: 560mm*275mm*385mm. Pallet size : 1200mm*800mm*132mm</p> <p>9.3 Palletizing: Box stacked - Module by air : (2 *4) *3 layers + one pallet put 18 boxes + total 144pcs module. Module by sea : One pallet (2 *4 *3 layers) No Double Pallet + total 192 pcs module. Module by sea_HQ : One pallet (2 *4 *3 layers) No Double Pallet Total 192 pcs module.</p> 	<p>Max capacity : 8 TFT-LCD module per carton. Max weight: 18.0 kg per carton. Outside dimension of carton: 601mm*261mm*412mm. Pallet size : 1060mm*760mm*132mm</p> <p>9.3 Palletizing: Box stacked - Module by air : (1 *4) *3 layers + one pallet put 12 boxes + total 96pcs module. Module by sea : Double pallet (1 *4) *3 layers + (1*4) * 1 layer + total 128 pcs module. Module by sea_HQ : Double pallet (1 *4) *3 layers + (1*4) * 2 layers + total 160 pcs module.</p> 																		
1.2	2021/09/14	5	2.1 Display Characteristics <table border="1"> <tr> <td>Temperature Range:</td> <td>[°C]</td> <td>0~ 60</td> </tr> <tr> <td>Operating</td> <td>[°C]</td> <td>-20~ 60</td> </tr> <tr> <td>Storage (Shipping)</td> <td>[°C]</td> <td>-20~ 60</td> </tr> </table>	Temperature Range:	[°C]	0~ 60	Operating	[°C]	-20~ 60	Storage (Shipping)	[°C]	-20~ 60	2.1 Display Characteristics <table border="1"> <tr> <td>Temperature Range:</td> <td>[°C]</td> <td>-10~ 60</td> </tr> <tr> <td>Operating</td> <td>[°C]</td> <td>-20~ 60</td> </tr> <tr> <td>Storage (Shipping)</td> <td>[°C]</td> <td>-20~ 60</td> </tr> </table>	Temperature Range:	[°C]	-10~ 60	Operating	[°C]	-20~ 60	Storage (Shipping)	[°C]	-20~ 60
		Temperature Range:	[°C]	0~ 60																		
		Operating	[°C]	-20~ 60																		
		Storage (Shipping)	[°C]	-20~ 60																		
Temperature Range:	[°C]	-10~ 60																				
Operating	[°C]	-20~ 60																				
Storage (Shipping)	[°C]	-20~ 60																				
10	4.2 Absolute Ratings of Environment. <table border="1"> <thead> <tr> <th>Item</th> <th>Symbol</th> <th>Min.</th> <th>Max.</th> <th>Unit.</th> </tr> </thead> <tbody> <tr> <td>Operating Temperature</td> <td>TOP</td> <td>0.</td> <td>60.</td> <td>[°C]</td> </tr> </tbody> </table>	Item	Symbol	Min.	Max.	Unit.	Operating Temperature	TOP	0.	60.	[°C]	4.2 Absolute Ratings of Environment. <table border="1"> <thead> <tr> <th>Item</th> <th>Symbol</th> <th>Min.</th> <th>Max.</th> <th>Unit.</th> </tr> </thead> <tbody> <tr> <td>Operating Temperature</td> <td>TOP</td> <td>-10.</td> <td>60.</td> <td>[°C]</td> </tr> </tbody> </table>	Item	Symbol	Min.	Max.	Unit.	Operating Temperature	TOP	-10.	60.	[°C]
Item	Symbol	Min.	Max.	Unit.																		
Operating Temperature	TOP	0.	60.	[°C]																		
Item	Symbol	Min.	Max.	Unit.																		
Operating Temperature	TOP	-10.	60.	[°C]																		
10	4.2 Absolute Ratings of Environment 	4.2 Absolute Ratings of Environment 																				
23	8.0 Reliability Test <table border="1"> <tr> <td>Low Temperature Operation (LTO)</td> <td>Ta= 0°C, 300hours.</td> </tr> </table>	Low Temperature Operation (LTO)	Ta= 0°C, 300hours.	8.0 Reliability Test <table border="1"> <tr> <td>Low Temperature Operation (LTO)</td> <td>Ta= -10°C, 300hours.</td> </tr> </table>	Low Temperature Operation (LTO)	Ta= -10°C, 300hours.																
Low Temperature Operation (LTO)	Ta= 0°C, 300hours.																					
Low Temperature Operation (LTO)	Ta= -10°C, 300hours.																					



1.0 Handling Precautions

- 1) Since front polarizer is easily damaged, please be cautious and not to scratch it.
- 2) Be sure to turn off power supply when inserting or disconnecting from input connector.
- 3) Wipe off water drop immediately. Long contact with water may cause discoloration or spots.
- 4) When the panel surface is soiled, wipe it with absorbent cotton or soft cloth.
- 5) Since the panel is made of glass, it may be broken or cracked if dropped or bumped on hard surface.
- 6) To avoid ESD (Electro Static Discharge) damage, be sure to ground yourself before handling TFT-LCD Module.
- 7) Do not open nor modify the module assembly.
- 8) Do not press the reflector sheet at the back of the module to any direction.
- 9) In case if a module has to be put back into the packing container slot after it was taken out from the container, do not press the center of the LED light bar edge. Instead, press at the far ends of the LED light bar edge softly. Otherwise the TFT Module may be damaged.
- 10) At the insertion or removal of the Signal Interface Connector, be sure not to rotate nor tilt the Interface Connector of the TFT Module.
- 11) TFT-LCD Module is not allowed to be twisted & bent even force is added on module in a very short time. Please design your display product well to avoid external force applying to module by end-user directly.
- 12) Small amount of materials having no flammability grade is used in the LCD module. The LCD module should be supplied by power complied with requirements of Limited Power Source (IEC60950-1 or UL60950-1), or be applied exemption.
- 13) Severe temperature condition may result in different luminance, response time and lamp ignition voltage.
- 14) Continuous operating TFT-LCD display under low temperature environment may accelerate lamp exhaustion and reduce luminance dramatically.
- 15) The data on this specification sheet is applicable when LCD module is placed in landscape position.
- 16) Continuous displaying fixed pattern may induce image sticking. It's recommended to use screen saver or shuffle content periodically if fixed pattern is displayed on the screen.



2.0 General Description

This specification applies to the 21.5 inch-wide Color AHVA (IPS-like) TFT-LCD Module G215HAN01.2. The display supports the FHD [1920(H) x 1080(V)] screen format and 16.7M colors. All input signals are LVDS interface compatible.

2.1 Display Characteristics

The following items are characteristics summary on the table under 25°C condition:

ITEMS	Unit	SPECIFICATIONS
Screen Diagonal	[mm]	21.5"
Active Area	[mm]	476.064 (H) x 267.786 (V)
Pixels H x V		1920(x3) x 1080
Pixel Pitch	[um]	247.95 (per one triad) x 247.95
Pixel Arrangement		R.G.B. Vertical Stripe
Display Mode		AHVA Mode, Normally Black
White Luminance (Center)	[cd/m ²]	300 cd/m ² (Typ.)
Contrast Ratio		1000 (Typ.)
Optical Response Time	[msec]	22
Nominal Input Voltage VDD	[Volt]	5 V (Typ)
Power Consumption (VDD line + LED line)	[Watt]	11.35 (Typ.) LCD module: PDD (Typ.)= 2.3 @ White pattern, Fv=60Hz Backlight unit : PBLU (Typ.) =9.05W
Weight	[Grams]	1740 (Typ)
Physical Size	[mm]	497.6(H) x 292.2(V) x 10.5 (D)Typ
Electrical Interface		Dual LVDS
Support Color		16.7M colors
Surface Treatment		Anti-Glare, 3H
RoHS Compliance		RoHS Compliance
Temperature Range		
Operating	[°C]	-10~ 60
Storage (Shipping)	[°C]	-20~ 60

2.2 Optical Characteristics

The optical characteristics are measured under stable conditions at 25 °C:

Item	Unit	Conditions	Min.	Typ.	Max.	Note
Central Luminance	cd/m ²	I _{LED} =65mA(center point)	240	300		1
Luminance Uniformity	%	9 points	75	80		2,3
Contrast ratio		Normal Direction	800	1000		4
Response Time	msec	Rising		12	22	5
		Falling		10	20	
		Rising + Falling		22	42	
Viewing Angle	degree	Horizontal (Right) CR >10 (Left)		89 89	- -	6
		Vertical (Up) CR > 10 (Down)		89 89	- -	
Color / Chromaticity Coordinates (CIE 1931)		Red x	0.616	0.646	0.676	
		Red y	0.305	0.335	0.365	
		Green x	0.274	0.304	0.334	
		Green y	0.585	0.615	0.645	
		Blue x	0.120	0.150	0.180	
		Blue y	0.031	0.061	0.091	
		White x	0.283	0.313	0.343	
White y	0.299	0.329	0.359			
Color Gamut	%			72		

Note 1: Measurement method

Equipment Pattern Generator, Power Supply, Digital Voltmeter, Luminance meter (SR_3 or equivalent)

Aperture 1φ with 50cm viewing distance

Test Point Center

Environment < 1 lux

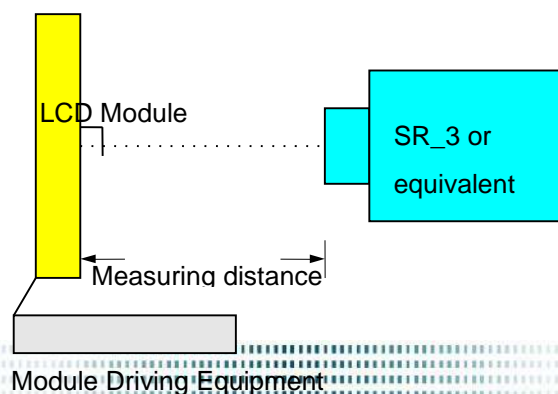

Note 2: Definition of 9 points position

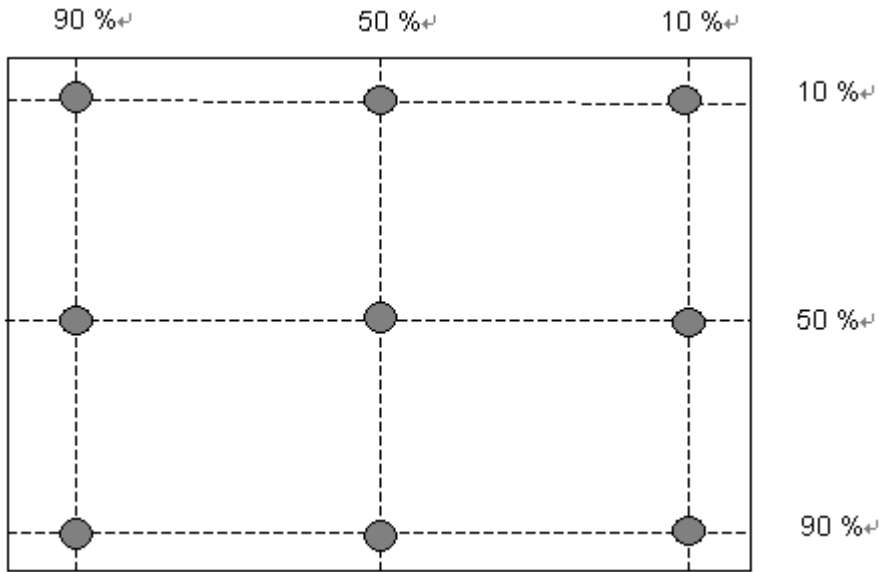

Note 3: The luminance uniformity of 9 points is defined by dividing the minimum luminance values by the maximum test point luminance

$$\delta_{w9} = \frac{\text{Minimum Brightness of 9 points}}{\text{Maximum Brightness of 9 points}}$$

Note 4: Definition of contrast ratio (CR):

$$\text{Contrast ratio (CR)} = \frac{\text{Brightness on the "White" state}}{\text{Brightness on the "Black" state}}$$

Note 5: Definition of response time:

The output signals of photo detector are measured when the input signals are changed from "White" to "Black" (falling time) and from "Black" to "White" (rising time), respectively. The response time interval is between 10% and 90% of amplitudes. Please refer to the figure as below.

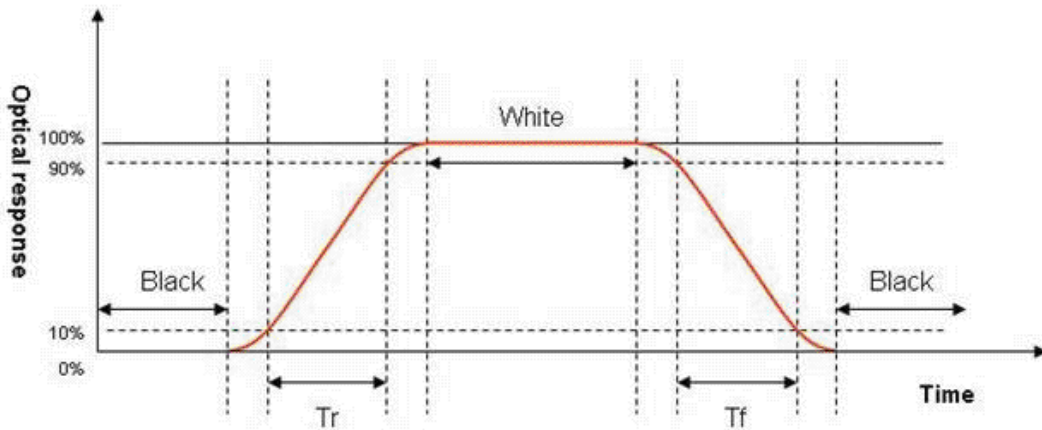
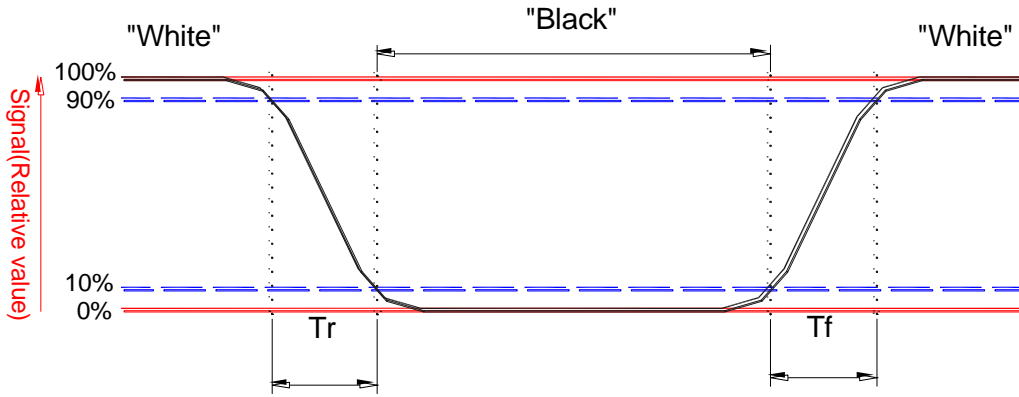

Note 6: Definition of viewing angle

Viewing angle is the measurement of contrast ratio ≥ 10 , at the screen center, over a 180° horizontal and 180° vertical range (off-normal viewing angles). The 180° viewing angle range is broken down as below: 90° (θ) horizontal left and right, and 90° (Φ) vertical high (up) and low (down). The measurement direction is typically perpendicular to the display surface with the screen rotated to its center to develop the desired measurement viewing angle.

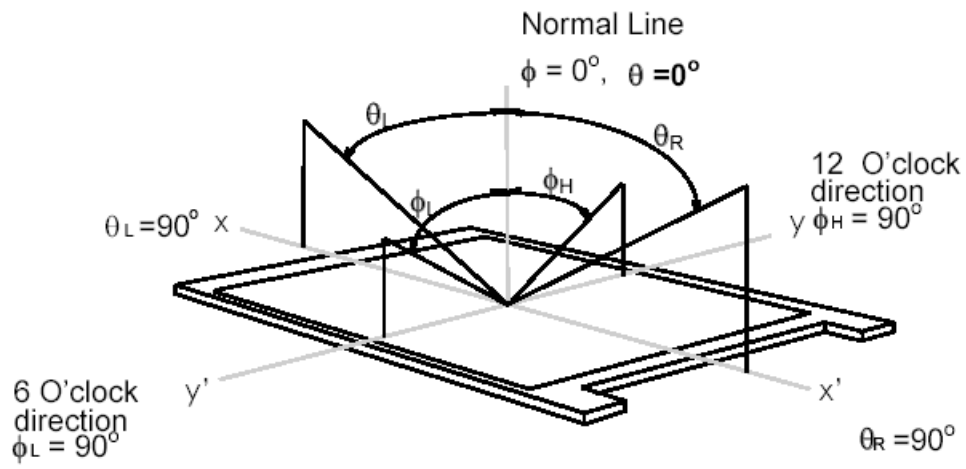

3.0 Functional Block Diagram

The following diagram shows the functional block of the 21.5 inch Color TFT-LCD Module:

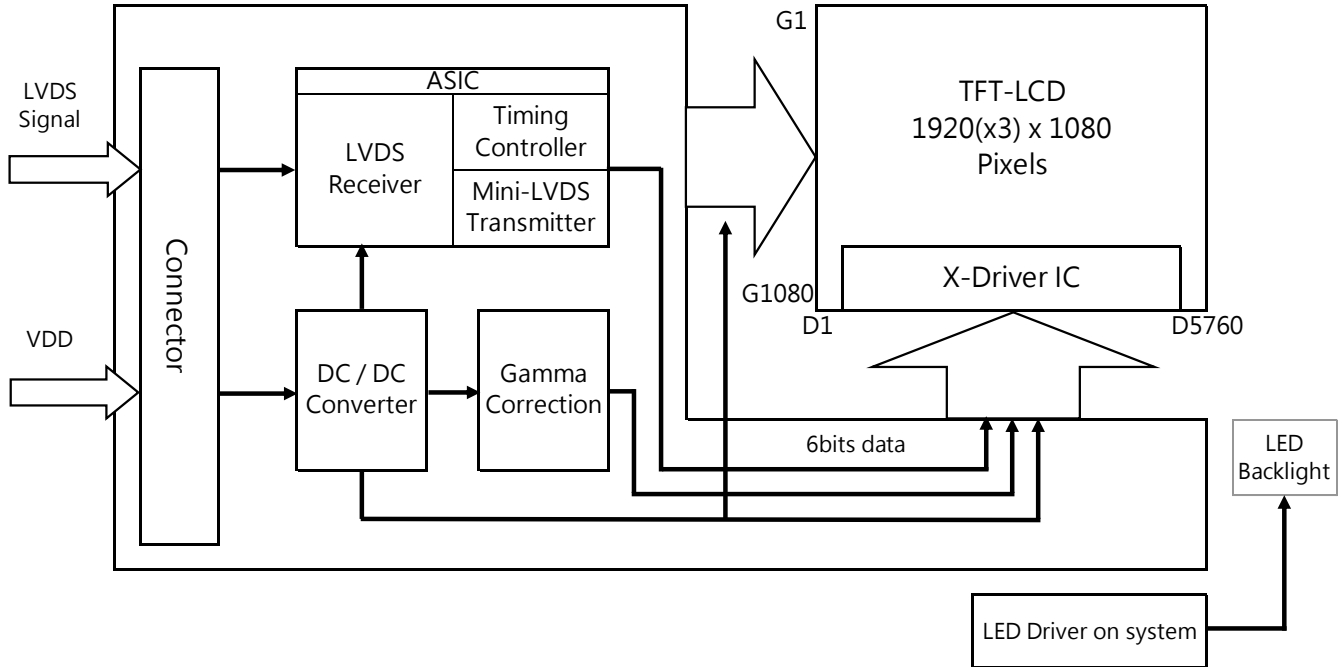

4.0 Absolute Maximum Ratings

Absolute maximum ratings of the module are as following:

4.1 TFT LCD Module

Item	Symbol	Min	Max	Unit	Conditions
Logic/LCD Drive Voltage	VDD	-0.3	+5.5	[Volt]	Note 1,2

4.2 Absolute Ratings of Environment

Item	Symbol	Min.	Max.	Unit	Conditions
Operating Temperature	TOP	-10	60	[°C]	Note 3 & 4
Operation Humidity	HOP	5	90	[%RH]	
Storage Temperature	TST	-20	60	[°C]	
Storage Humidity	HST	5	90	[%RH]	

Note 1: With in Ta (25 °C)

Note 2: Permanent damage to the device may occur if exceeding maximum values

Note 3: For quality performance, please refer to AUO IIS(Incoming Inspection Standard).

Note 4: Operation Temperature +60°C is defined as panel surface temperature.

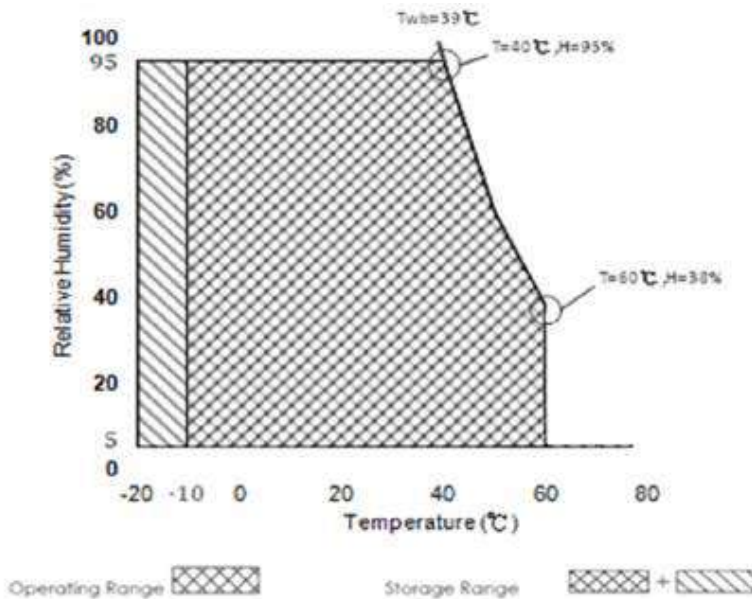

5.0 Electrical characteristics

5.1 TFT LCD Module

5.1.1 Power Specification

Input power specifications are as follows:

Symbol	Parameter	Min	Typ	Max	Unit	Conditions
VDD	Logic/LCD Drive Voltage	4.5	5.0	5.5	[Volt]	+/-10%
IDD	Input Current	-	0.46	0.55	[A]	VDD= 5.0V, All White Pattern At 60Hz,
PDD	VDD Power	-	2.3	2.75	[Watt]	VDD= 5.0V, All White Pattern At 60Hz
IRush	Inrush Current	-		3.0	[A]	Note 1
VDDrp	Allowable Logic/LCD Drive Ripple Voltage	-	-	500	[mV] p-p	VDD= 5.0V, All White Pattern At 60Hz

Note 1: Measurement conditions:

The duration of rising time of power input is 470us.

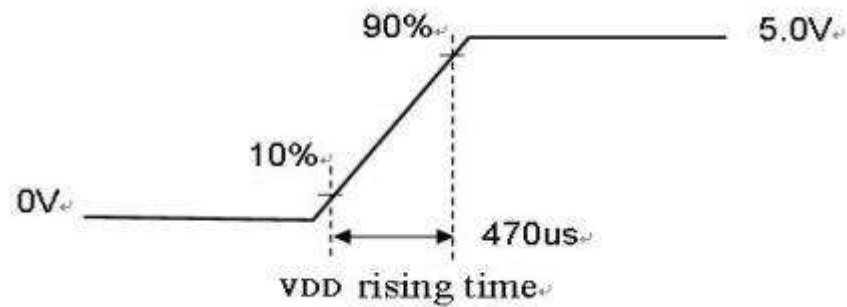
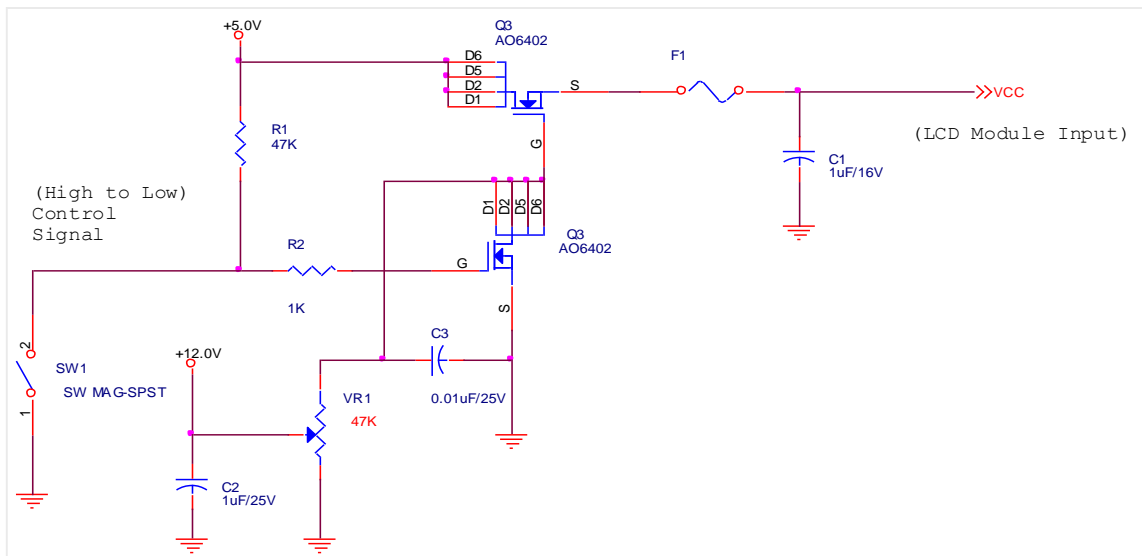

5.1.2 Signal Electrical Characteristics

Input signals shall be low or Hi-Z state when VDD is off. Please refer to specifications of SN75LVDS82DGG (Texas Instruments) in detail.

Characteristics of each signal are as follows:

Symbol	Parameter	Min	Typ	Max	Units	Condition
V _{TH}	Differential Input High Threshold			100	[mV]	V _{ICM} = 1.2V Note 1
V _{TL}	Differential Input Low Threshold	-100			[mV]	V _{ICM} = 1.2V Note 1
V _{ID}	Input Differential Voltage	100	400	600	[mV]	Note 1
V _{ICM}	Differential Input Common Mode Voltage	1.0	1.2	1.5	[V]	V _{TH} -V _{TL} = 200mV (max) Note 1

Note 1: LVDS Signal Waveform

Use RxOCLK- & RxOCLK+ as example.

Single-End

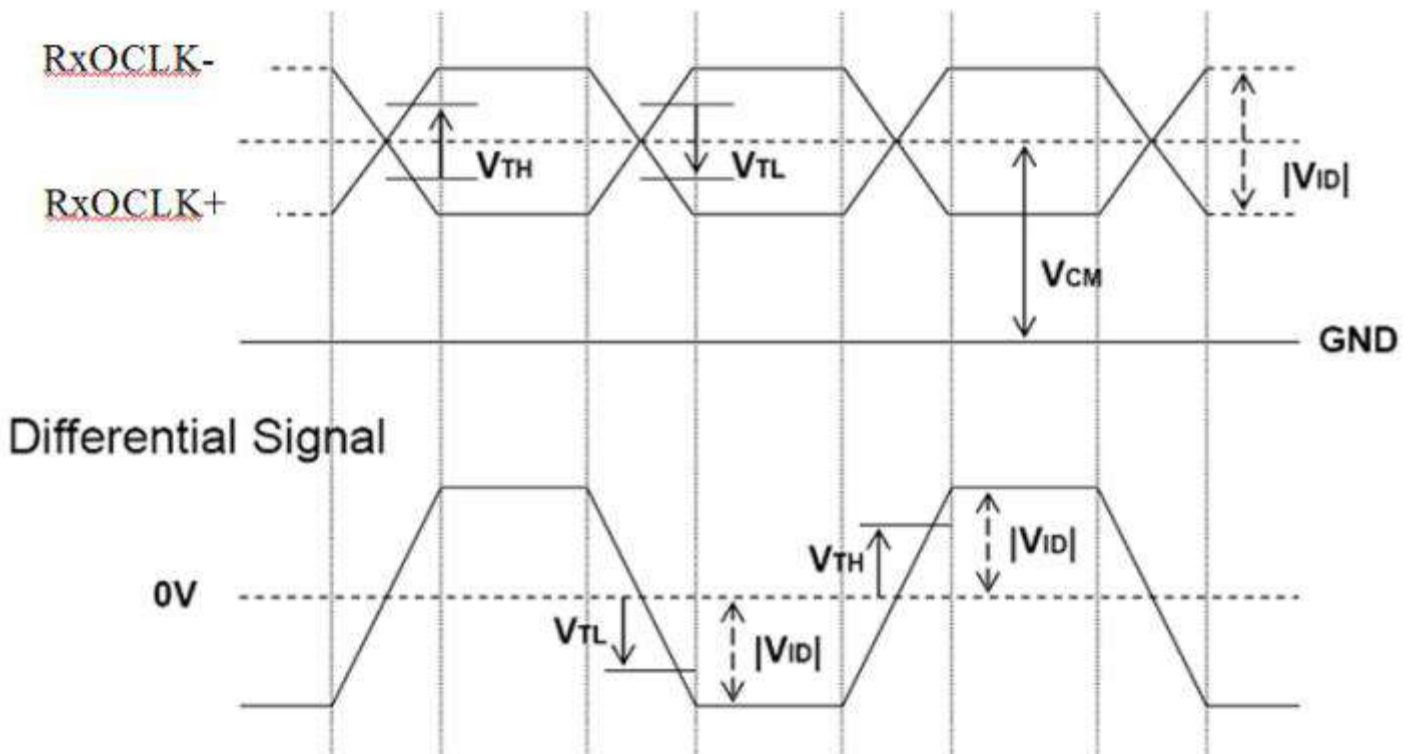

5.2 Backlight Unit

Following characteristics are measured under a stable condition at 25 °C (Room Temperature):

Symbol	Parameter	Min.	Typ.	Max.	Unit	Remark
IL	LED Supply Current		65		mA	Ta = 25 °C
VL	LED Supply Voltage	-	2.9	3.1	Volt	I _F =65 mA, Ta = 25°C
PLED	LED Power Consumption	-	0.189		Watt	I _F =65 mA, Ta = 25°C
LL	LED Life Time	50,000			Hrs	I _F =65 mA, Ta= 25°C

Note 1: Ta means ambient temperature of TFT-LCD module.

Note 2: I_F, V_F, P_{LED} are defined for single LED.

Note 3: If G215HAN01.2 module is driven by high current or at high ambient temperature & humidity condition. The operating life will be reduced.

Note 4: Operation life means brightness goes down to 50% initial brightness. Minimum operating life time is estimated data.

Note 4: Each LED light bar consists of 48 pcs LED package (4 strings x 12 pcs / string)

6.0 Signal Characteristic

6.1 Pixel Format Image

Following figure shows the relationship of the input signals and LCD pixel format.

	1			2				1919			1920		
1st Line	R	G	B	R	G	B	R	G	B	R	G	B
	-	-	-	-	-	-	-	-	-	-	-	-	-

1080 Line	R	G	B	R	G	B	R	G	B	R	G	B

6.2 The input data format

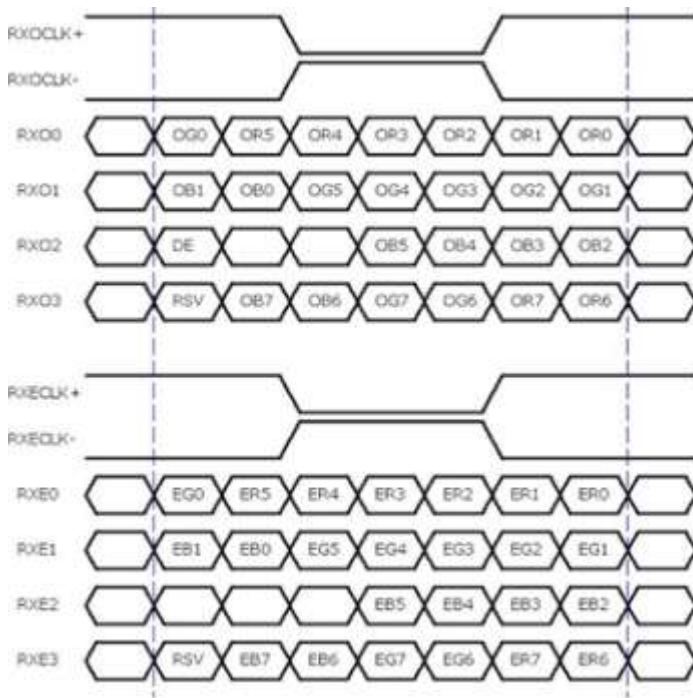

8 Bit Color Bit Order			
MSB	R7	G7	B7
	R6	G6	B6
	R5	G5	B5
	R4	G4	B4
	R3	G3	B3
	R2	G2	B2
	R1	G1	B1
LSB	R0	G0	B0

Note1: Normally DE mode only. VS and HS on EVEN channel are not used.

Note2: Please follow VESA.

Note3: 8-bits signal input.

6.3 Signal Description

The module using a pair of LVDS receiver **SN75LVDS82 / SN75LVDS83**

(Texas Instruments) or compatible. LVDS is a differential signal technology for LCD interface and high speed data transfer device. Transmitter shall be SN75LVDS83(negative edge sampling) or compatible. The first LVDS port(RxOxxx) transmits odd pixels while the second LVDS port(RxExxx) transmits even pixels.

PIN #	SIGNAL NAME	DESCRIPTION
1	RxO0-	Negative LVDS differential data input (Odd data)
2	RxO0+	Positive LVDS differential data input (Odd data)
3	RxO1-	Negative LVDS differential data input (Odd data)
4	RxO1+	Positive LVDS differential data input (Odd data)
5	RxO2-	Negative LVDS differential data input (Odd data)
6	RxO2+	Positive LVDS differential data input (Odd data)
7	GND	Ground
8	RxOCLK-	Negative LVDS differential clock input (Odd clock)
9	RxOCLK+	Positive LVDS differential clock input (Odd clock)
10	RxO3-	Negative LVDS differential data input (Odd data)
11	RxO3+	Positive LVDS differential data input (Odd data)
12	RxE0-	Negative LVDS differential data input (Even data)
13	RxE0+	Positive LVDS differential data input (Even data)
14	GND	Ground
15	RxE1-	Negative LVDS differential data input (Even data)
16	RxE1+	Positive LVDS differential data input (Even data)
17	GND	Ground
18	RxE2-	Negative LVDS differential data input (Even data)
19	RxE2+	Positive LVDS differential data input (Even data)
20	RxECLK-	Negative LVDS differential clock input (Even clock)
21	RxECLK+	Positive LVDS differential clock input (Even clock)
22	RxE3-	Negative LVDS differential data input (Even data)
23	RxE3+	Positive LVDS differential data input (Even data)
24	GND	Ground
25	NC	No connection (for AUO test only. Do not connect)
26	NC	No connection (for AUO test only. Do not connect)
27	NC	No connection (for AUO test only. Do not connect)
28	VDD	Power Supply Input Voltage

29	VDD	Power Supply Input Voltage
30	VDD	Power Supply Input Voltage

Note1: Start from right side

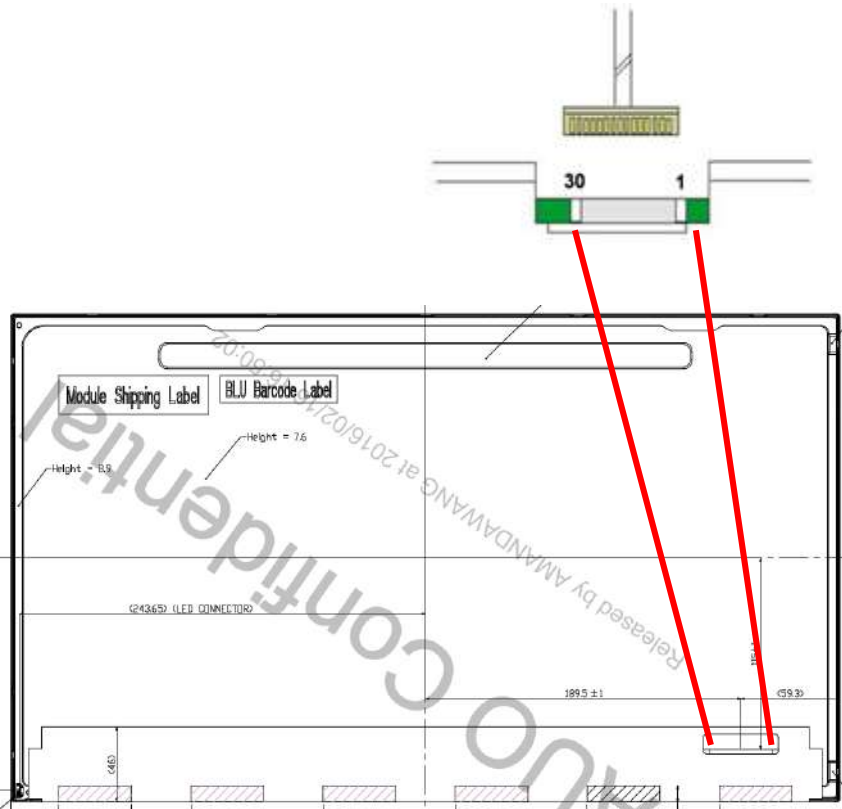



Note2: Input signals of clock shall be the same timing.

Note3: Please follow TV VESA Pin Assignment

6.4 Timing Characteristics

Signal	Item	Symbol	Min	Typ	Max	Unit
V-section	Period	Tv	1094	1130	1836	Th
	Active	Tdisp(v)	1080	1080	1080	Th
	Blanking	Tbp(v)+Tfp(v)+PWvs	14	50	756	Th
H-section	Period	Th	1000	1050	1678	Tclk
	Active	Tdisp(h)	960	960	960	Tclk
	Blanking	Tbp(h)+Tfp(h)+PWhs	40	90	718	Tclk
Clock	Period	Tclk	11.2	14	18.6	ns
	Frequency	Freq.	53.7	71.2	90	MHz
Frame Rate	Frame Rate	1/Tv	49	60	76	Hz

Note 1: Only DE mode operation.

The input of Hsync & Vsync signal does not have an effect upon the LCD normal operation.

Note 2: The performance of the electro-optical characteristics may be influenced by variance of the vertical refresh rates.

Note 3: Horizontal period should be even.

6.5 Timing diagram

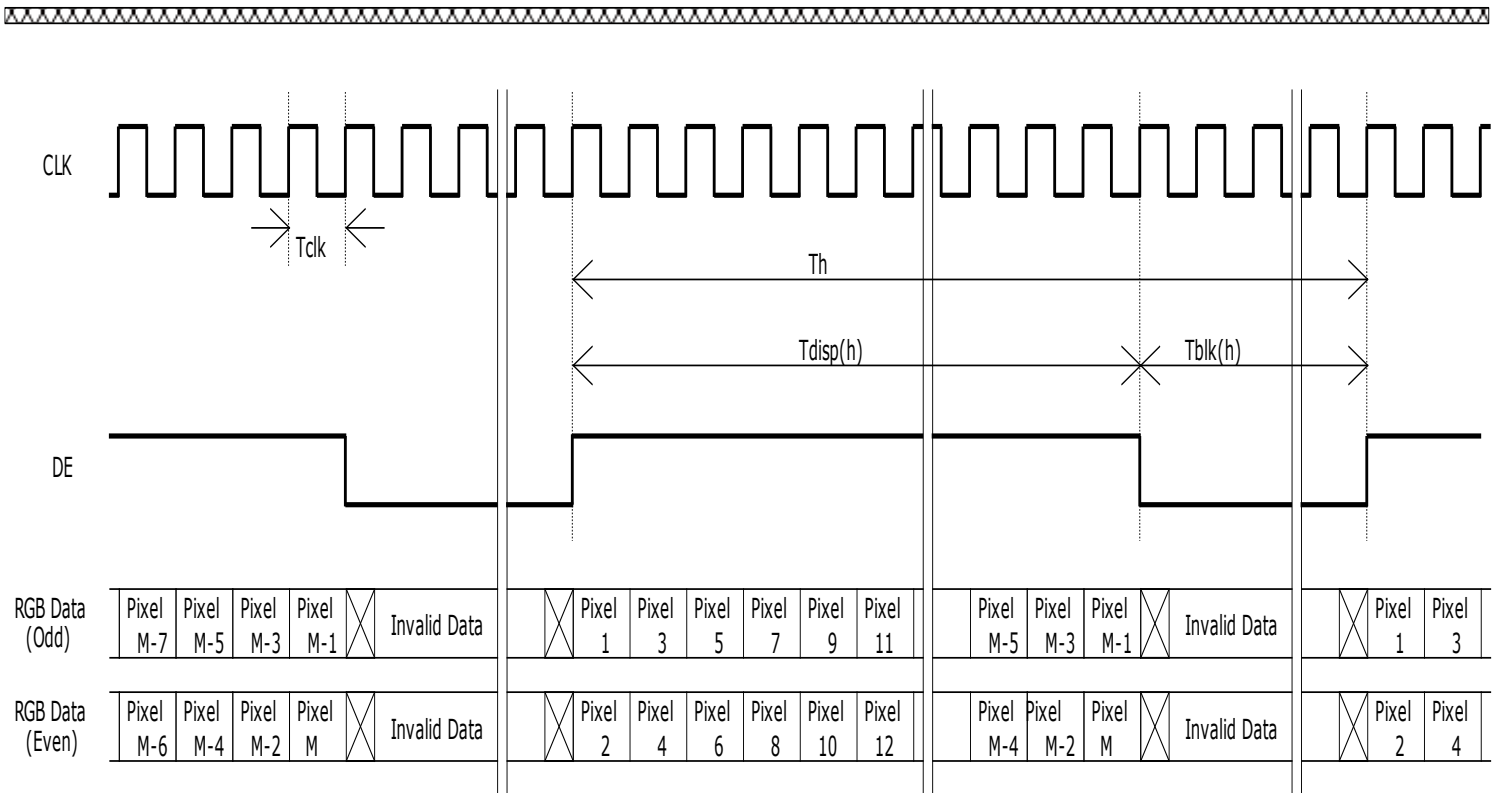
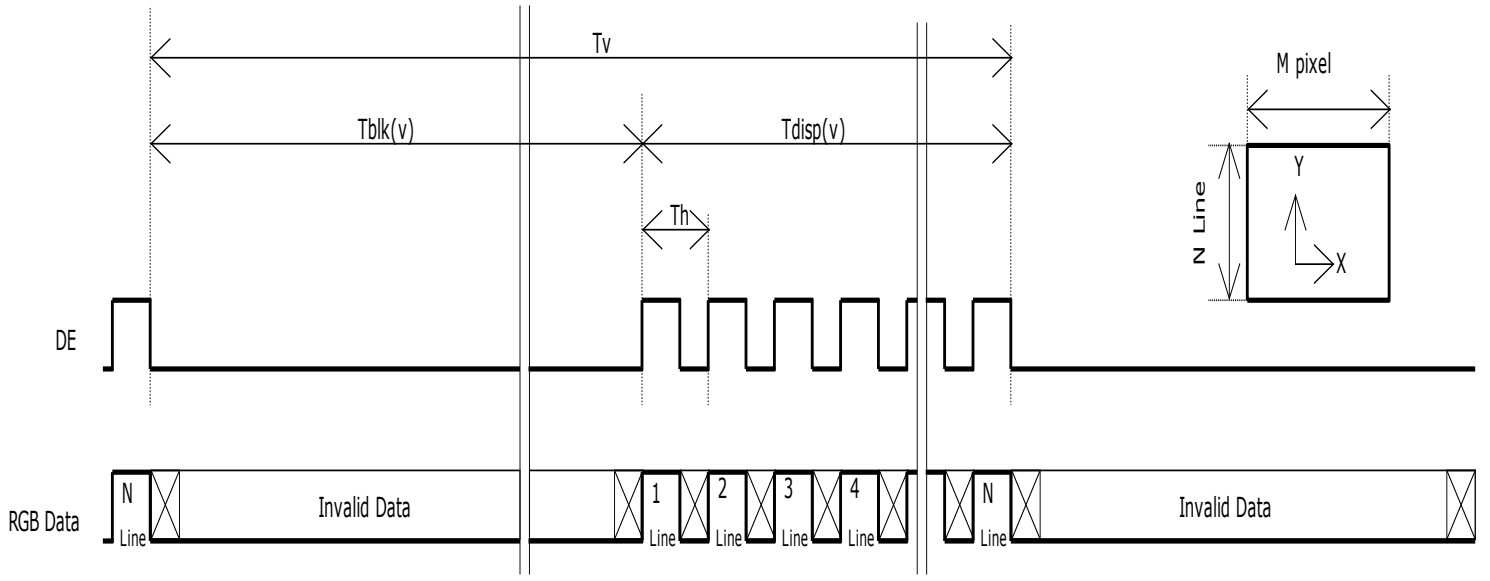

6.6 Power ON/OFF Sequence

VDD power and LED on/off sequence are as follows. Interface signals are also shown in the chart. Signals from any system shall be Hi-Z state or low level when VDD is off.

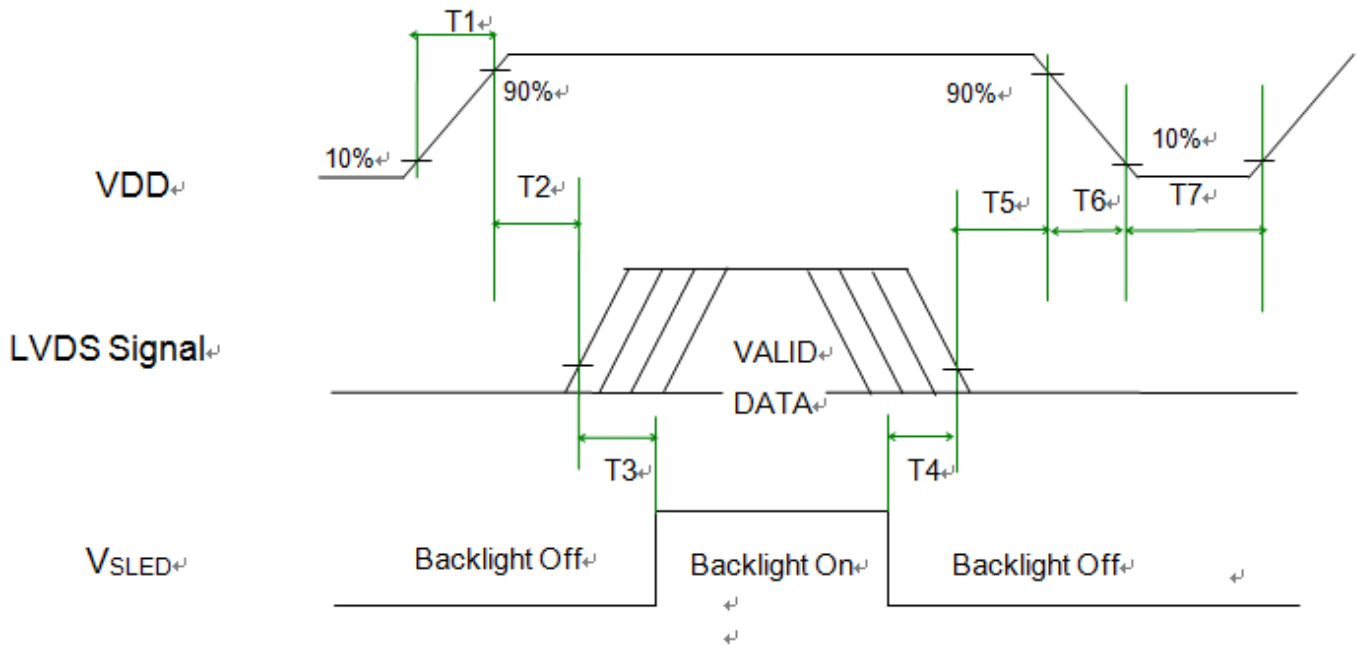

Power ON/OFF sequence timing

Parameter	Value			Units
	Min.	Typ.	Max.	
T1	0.5	-	10	[ms]
T2	0	-	50	[ms]
T3	500	-	-	[ms]
T4	100	-	-	[ms]
T5	0	-	50	[ms]
T6	0	-	200	[ms]
T7	1000	-	-	[ms]

7.0 Connector & Pin Assignment

Physical interface is described as for the connector on module. These connectors are capable of accommodating the following signals and will be following components.

7.1 TFT LCD Module

Connector Name / Designation	Interface Connector / Interface card
Manufacturer	STM
Type Part Number	MSBKT2407P30HB
Mating Housing Part Number	FI-X30HL or FI-X30C2L-NPB

7.1.1 Pin Assignment

Pin#	Signal Name	Pin#	Signal Name
1	RxOIN0-	2	RxOIN0+
3	RxOIN1-	4	RxOIN1+
5	RxOIN2-	6	RxOIN2+
7	GND	8	RxOCLKIN-
9	RxOCLKIN+	10	RxOIN3-
11	RxOIN3+	12	RxEIN0-
13	RxEIN0+	14	GND
15	RxEIN1-	16	RxEIN1+
17	GND	18	RxEIN2-
19	RxEIN2+	20	RxECLKIN-
21	RxECLKIN+	22	RxEIN3-
23	RxEIN3+	24	GND
25	Aging	26	SCL For PVCOM
27	SDA For PVCOM	28	VDD
29	VDD	30	VDD

7.2 LED Backlight Unit: LED Connector

Connector Name / Designation	LED Connector
Manufacturer	ENTERY or equivalent
Connector Model Number	3707K-S06N-21R or equivalent
Mating Connector Model Number	H112K-P06N-00B (Non-Locking type) H112K-P06N-13B (Locking type)

7.3 LED Connector Pin Assignment

Pin#	Symbol	Description
1	Ch1	LED Current Feedback Terminal (Channel 1)
2	Ch2	LED Current Feedback Terminal (Channel 2)
3	V _{SLED}	LED Power Supply Voltage Input Terminal
4	V _{SLED}	LED Power Supply Voltage Input Terminal
5	Ch3	LED Current Feedback Terminal (Channel 3)
6	Ch4	LED Current Feedback Terminal (Channel 4)

Drawing

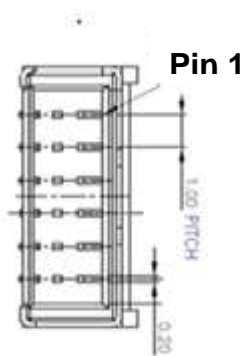



8.0 Reliability Test

Environment test conditions are listed as following table.

Items	Required Condition	Note
Temperature Humidity Bias (THB)	Ta= 50°C, 80%RH, 300hours	
High Temperature Operation (HTO)	Ta= 60°C, 300hours	
Low Temperature Operation (LTO)	Ta= -10°C, 300hours	
High Temperature Storage (HTS)	Ta= 60°C, 300hours	
Low Temperature Storage (LTS)	Ta= -20°C, 300hours	
Vibration Test (Non-operation)	Acceleration: 1.5 Grms Wave: Random Frequency: 10 - 200 Hz Sweep: 30 Minutes each Axis (X, Y, Z)	
Shock Test (Non-operation)	Acceleration: 50 G Wave: Half-sine Active Time: 20 ms Direction: ±X, ±Y, ±Z (one time for each Axis)	
Thermal Shock Test (TST)	-20°C /30min, 60°C /30min, 100 cycles	1
On/Off Test	On/10sec, Off/10sec, 30,000 cycles	
ESD (Electro Static Discharge)	Contact Discharge: ± 8KV, 150pF(330Ω) 1sec, 8 points, 25 times/ point.	2
	Air Discharge: ± 15KV, 150pF(330Ω) 1sec 8 points, 25 times/ point.	

Note 1: The TFT-LCD module will not sustain damage after being subjected to 100 cycles of rapid temperature change. A cycle of rapid temperature change consists of varying the temperature from -20°C to 60°C, and back again. Power is not applied during the test. After temperature cycling, the unit is placed in normal room ambient for at least 4 hours before power on.

Note 2: According to EN61000-4-2 , ESD class B: Some performance degradation allowed. No data lost. Self-recoverable. No hardware failures.

Note 3 : Mura shall be ignored after high temperature reliability test.

9.0 Shipping Label & Packaging

9.1 Shipping Label

The label is on the panel as shown below:

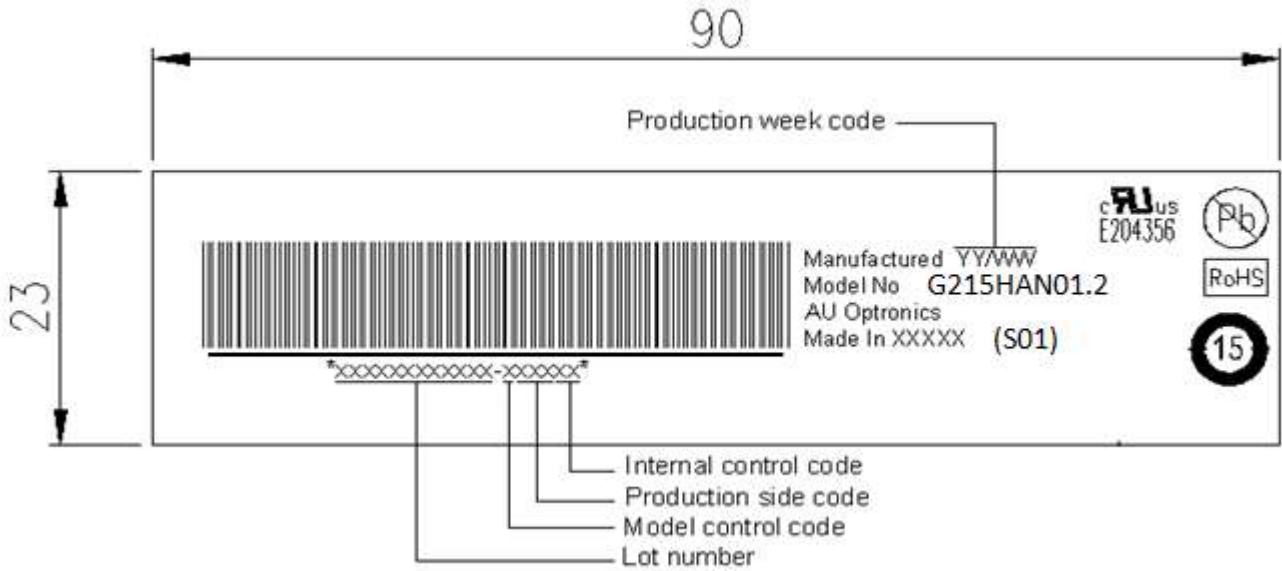

Note 1: For Pb Free products, AUO will add  for identification.

Note 2: For RoHS compatible products, AUO will add  for identification.

Note 3: For China RoHS compatible products, AUO will add  for identification.

Note 4: The Green Mark will be presented only when the green documents have been ready by AUO Internal Green Team.

9.2 Packaging

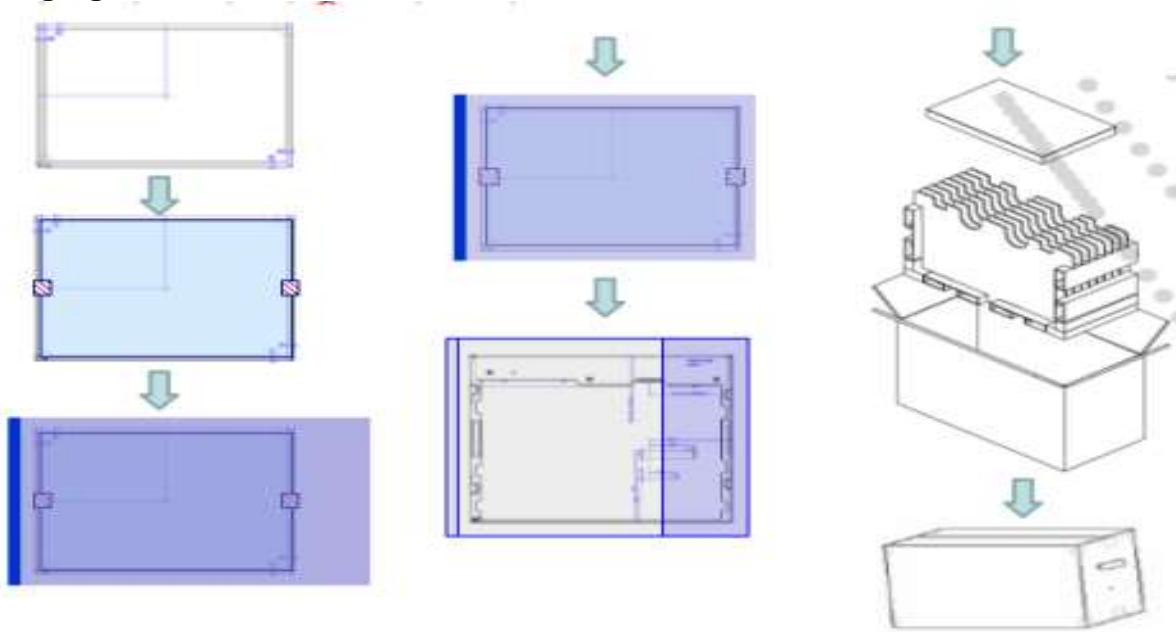

Max capacity : 8 TFT-LCD module per carton
 Max weight: 18.0 kg per carton
 Outside dimension of carton: 601mm*261mm*412mm
 Pallet size : 1060mm*760mm*132mm

9.3 Palletizing

Box stacked

Module by air : (1 *4) *3 layers , one pallet put 12 boxes , total 96pcs module

Module by sea : Double pallet (1 *4) *3 layers + (1*4) * 1 layer , total 128 pcs module

Module by sea_ HQ : Double pallet (1 *4) *3 layers + (1*4) * 2 layers , total 160 pcs module

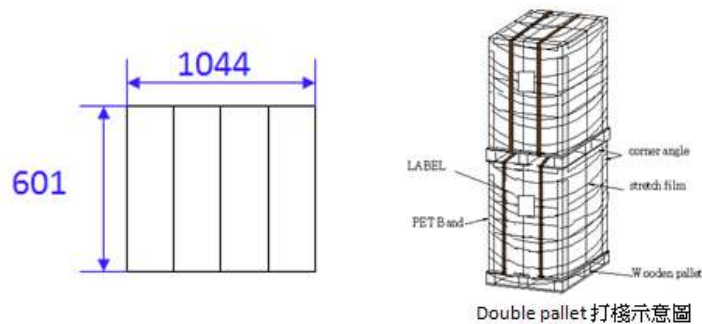

By air : one pallet
 By sea: double pallet

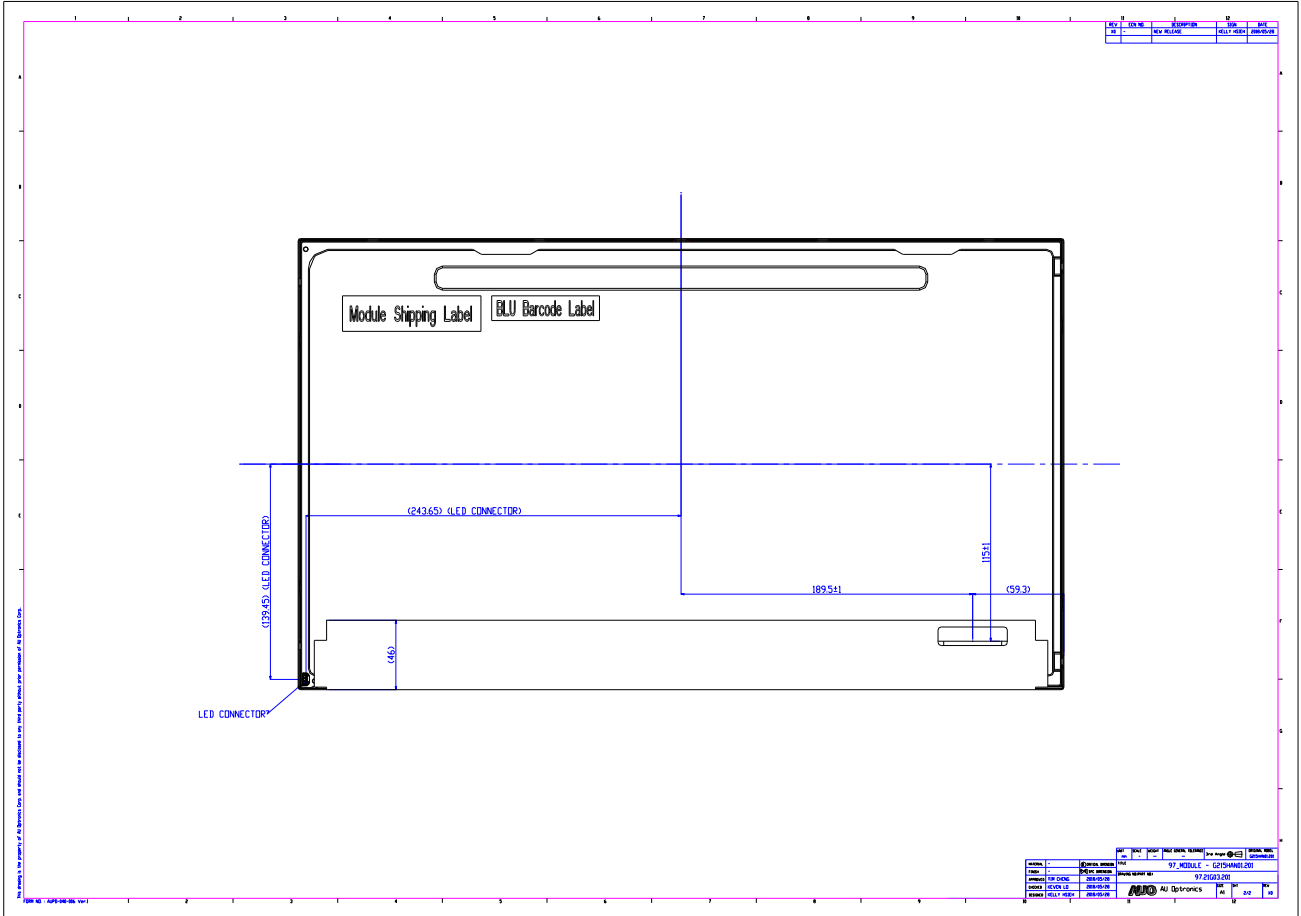



11 Safety

11.1 Sharp Edge Requirements

There will be no sharp edges or comers on the display assembly that could cause injury.

11.2 Materials

11.2.1 Toxicity

There will be no carcinogenic materials used anywhere in the display module. If toxic materials are used, they will be reviewed and approved by the responsible AUO toxicologist.

11.2.2 Flammability

All components including electrical components that do not meet the flammability grade UL94-V1 in the module will complete the flammability rating exception approval process.

The printed circuit board will be made from material rated 94-V1 or better. The actual UL flammability rating will be printed on the printed circuit board.

11.3 Capacitors

If any polarized capacitors are used in the display assembly, provisions will be made to keep them from being inserted backwards.

11.4 National Test Lab Requirement

The display module will satisfy all requirements for compliance to:

UL 60950-1, Second Edition

U.S.A. Information Technology Equipment