

SPECIFICATION FOR APPROVAL

() Preliminary Specification

(●) Final Specification

Title	55.0" WUXGA TFT LCD
-------	---------------------

BUYER	GENERAL
MODEL	

SUPPLIER	LG DISPLAY Co., Ltd.
*MODEL	LD550DUN
SUFFIX	TMA3(RoHS Verified)

APPROVED BY	SIGNATURE DATE
/	_____
/	_____
/	_____

APPROVED BY	SIGNATURE DATE
JaeBum Chun / Team Leader	_____
REVIEWED BY	
JongSeob Won / Project Leader	_____
PREPARED BY	
HyoJoon Park / Engineer	_____

Please return 1 copy for your confirmation with your signature and comments.

**PD Product Design Dept.
LG Display Co., Ltd**

Product Specification

CONTENTS

Number	ITEM	Page
	COVER	1
	CONTENTS	2
	RECORD OF REVISIONS	3
1	GENERAL DESCRIPTION	4
2	ABSOLUTE MAXIMUM RATINGS	5
3	ELECTRICAL SPECIFICATIONS	6
3-1	ELECTRICAL CHARACTERISTICS	6
3-2	INTERFACE CONNECTIONS	8
3-3	SIGNAL TIMING SPECIFICATIONS	10
3-4	LVDS SIGNAL SPECIFICATIONS	12
3-5	COLOR DATA REFERENCE	15
3-6	POWER SEQUENCE	16
4	OPTICAL SPECIFICATIONS	18
5	MECHANICAL CHARACTERISTICS	22
6	RELIABILITY	26
7	INTERNATIONAL STANDARDS	27
7-1	SAFETY	27
7-2	ENVIRONMENT	27
8	PACKING	28
8-1	INFORMATION OF LCM LABEL	28
8-2	PACKING FORM	28
9	PRECAUTIONS	29
9-1	MOUNTING PRECAUTIONS	29
9-2	OPERATING PRECAUTIONS	29
9-3	ELECTROSTATIC DISCHARGE CONTROL	30
9-4	PRECAUTIONS FOR STRONG LIGHT EXPOSURE	30
9-5	STORAGE	30
9-6	HANDLING PRECAUTIONS FOR PROTECTION FILM	30
9-7	APPROPRIATE CONDITION FOR commercial DISPLAY	30

Product Specification

RECORD OF REVISIONS

Revision No.	Revision Date	Page	Description
1.0	Nov. 26. 2018	-	Final CAS

1. General Description

The LD550DUN is a Color Active Matrix Liquid Crystal Display with an integral Light Emitting Diode (LED) Local Block backlight system. The matrix employs a-Si Thin Film Transistor as the active element. It is a transmissive display type which is operating in the normally black mode. It has a 54.64 inch diagonally measured active display area with WUXGA resolution (1080 vertical by 1920 horizontal pixel array). Each pixel is divided into Red, Green and Blue sub-pixels or dots which are arrayed in vertical stripes. Gray scale or the luminance of the sub-pixel color is determined with a 10-bit gray scale signal for each dot. Therefore, it can present a palette of more than 1.07Billion colors.

It has been designed to apply the 10-bit 2-port LVDS interface.

It is intended to support commercial Display where high brightness, super wide viewing angle, high color gamut, high color depth and fast response time are important.

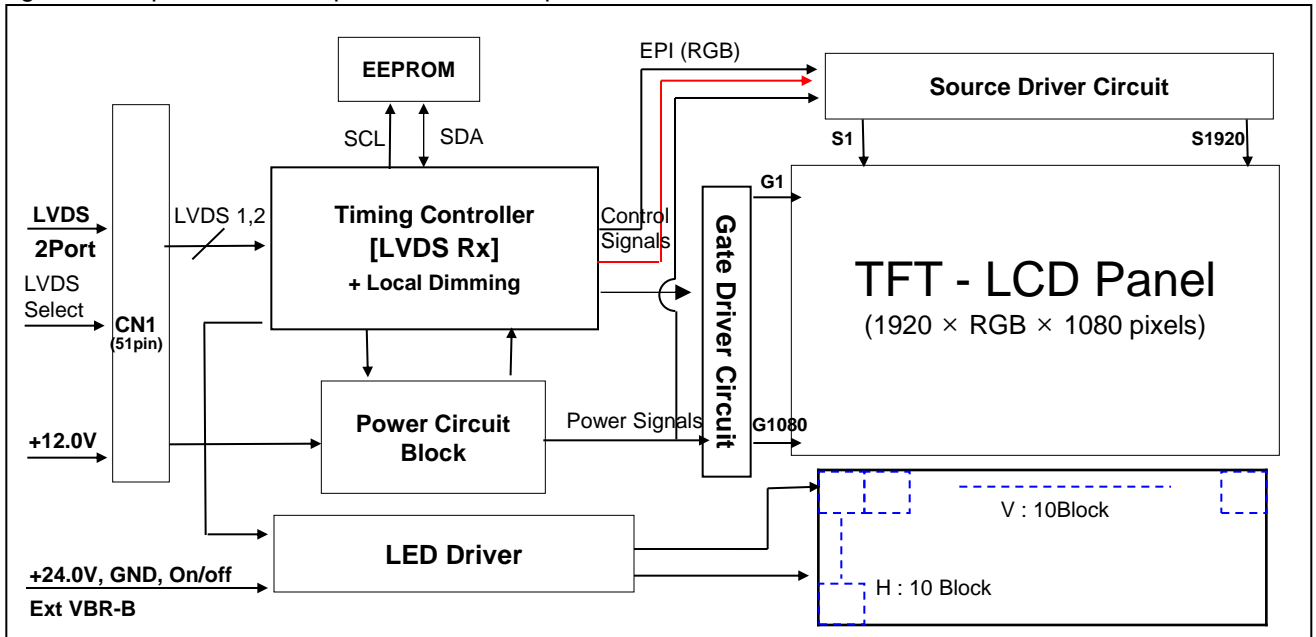

General Features

Active Screen Size	54.64 inches(1387.83mm) diagonal
Outline Dimension	1210.51 x 681.22 x 53.3(D)
Pixel Pitch	0.630(H) X 0.630(V)
Pixel Format	1920 horiz. by 1080 vert. Pixels, RGB stripe arrangement
Color Depth	10Bit (D), 1.07 Billion colors
Luminance, White	700 cd/m2 (Center 1point ,Typ.)
Viewing Angle (CR>10)	Viewing angle free (R/L 178 (Min.), U/D 178 (Min.))
Power Consumption	Total 203.6W (Typ.) [Logic=6.6W, Backlight=197.0W(@EXTVBR-B = 100%)]
Weight	12,500g (Typ.)
Display Mode	Transmissive mode, Normally black
Surface Treatment	Hard Coating(2H), Anti-glare treatment of the front polarizer (Haze 28%)
Possible Display Type	Landscape and Portrait Enabled

2. Absolute Maximum Ratings

The following items are maximum values which, if exceeded, may cause faulty operation or damage to the LCD module.

Table 1. ABSOLUTE MAXIMUM RATINGS

Parameter		Symbol	Value		Unit	Note
			Min	Max		
Power Input Voltage	LCD Circuit	V _{LCD}	-0.3	+14.0	V _{DC}	1
	Driver	V _{BL}	-0.3	+ 27.0	V _{DC}	
Driver Control Voltage	ON/OFF	V _{ON/OFF}	-0.3	+3.9	V _{DC}	
	Brightness	EXTVBR-B	-0.3	+3.9	V _{DC}	
	Status	Status	-0.3	+3.9	V _{DC}	
T-Con Option Selection Voltage		V _{LOGIC}	-0.3	+4.0	V _{DC}	
Operating Temperature		T _{OP}	0	+50	°C	2,3
Storage Temperature		T _{ST}	-20	+60	°C	
Panel Front Temperature		T _{SUR}	-	+68	°C	4
Operating Ambient Humidity		H _{OP}	10	90	%RH	2,3
Storage Humidity		H _{ST}	5	90	%RH	

Note.

1. Ambient temperature condition ($T_a = 25 \pm 2 \text{ }^\circ\text{C}$)
2. Temperature and relative humidity range are shown in the figure below.
Wet bulb temperature should be Max 39°C, and no condensation of water.
3. Gravity mura can be guaranteed below 40°C condition.
4. The maximum operating temperatures is based on the test condition that the surface temperature of display area is less than or equal to 68°C with LCD module alone in a temperature controlled chamber. Thermal management should be considered in final product design to prevent the surface temperature of display area from being over 68°C. The range of operating temperature may be degraded in case of improper thermal management in final product design.

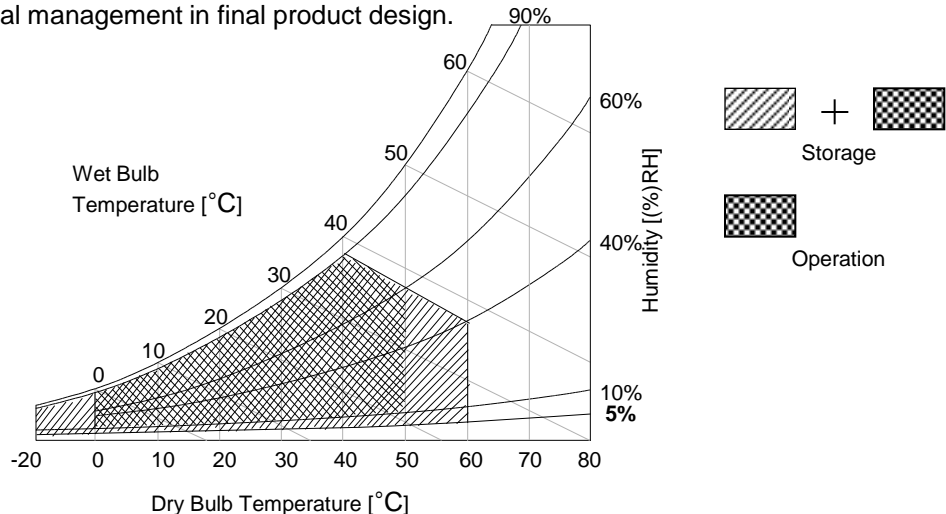

Product Specification

3. Electrical Specifications

3-1. Electrical Characteristics

It requires two power inputs. One is employed to power for the LCD circuit. The other is used for the LED backlight and LED Driver circuit.

Table 2. ELECTRICAL CHARACTERISTICS

Parameter		Symbol	Value			Unit	Note
			Min	Typ	Max		
Circuit :							
Power Input Voltage		V _{LCD}	10.8	12.0	13.2	V _{DC}	
Power Input Current		I _{LCD}	-	550	715	mA	1
			-	680	884	mA	2
T-CON Option Selection Voltage	Input High Voltage	V _{IH}	2.7	-	3.6	V _{DC}	
	Input Low Voltage	V _{IL}	0	-	0.7	V _{DC}	
Power Consumption		P _{LCD}	-	6.6	8.58	Watt	1
Rush current		I _{RUSH}	-	-	6	A	3

- Notes: 1. The specified current and power consumption are under the $V_{LCD}=12.0V$, $25 \pm 2^{\circ}C$, $f_v=60Hz$ condition whereas mosaic pattern(8 x 6) is displayed and f_v is the frame frequency.
 2. The current is specified at maximum current pattern.
 3. The duration of rush current is about 2ms and rising time of power input is 0.5ms (min.).
 4. Ripple voltage level is recommended under $\pm 5\%$ of typical voltage

White : 1023Gray
 Black : 0Gray

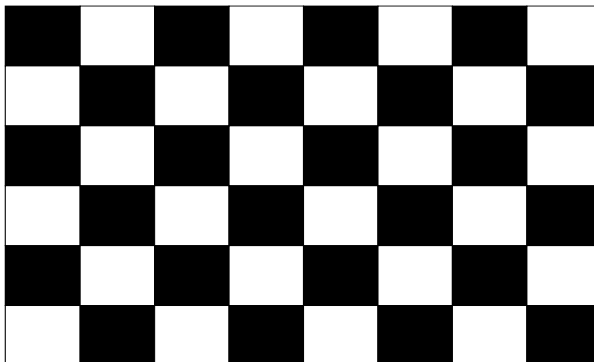

Mosaic Pattern(8 x 6)

Product Specification

Table 3. ELECTRICAL CHARACTERISTICS (Continue)

Parameter			Symbol	Values			Unit	Notes	
				Min	Typ	Max			
LED Driver :									
Power Supply Input Voltage			VBL	21.6	24.0	26.4	Vdc	1	
Power Supply Input Current			IBL	-	8.2	9.6	A	Ext V _{BR-B} = 100%	
Power Supply Input Current (In-Rush)			Irush	-	-	12.5	A	V _{BL} = 21.6V Ext V _{BR-B} = 100% 3	
Power Consumption			PBL	-	197.0	230.3	W	Ext V _{BR-B} = 100%	
Input Voltage for Control System Signals	On/Off	On	V on	2.5	-	3.6	Vdc	On Duty, 5	
		Off	V off	-0.3	0.0	0.7	Vdc		
	Brightness Adjust		ExtV _{BR-B}	1	-	100	%		
	PWM Frequency for NTSC & PAL		PAL		100		Hz		2
			NTSC		120		Hz		2
	Pulse Duty Level (PWM)		High Level	2.5	-	3.6	Vdc		HIGH : on duty LOW : off duty
Low Level			0.0	-	0.7	Vdc			
LED :									
Life Time				50,000			Hrs	6	

Notes :

- Electrical characteristics are determined after the unit has been 'ON' and stable for approximately 60 minutes at $25 \pm 2^\circ\text{C}$. The specified current and power consumption are under the typical supply Input voltage 24V and V_{BR} (ExtV_{BR-B} : 100%), it is total power consumption.
- LGD recommend that the PWM freq. is synchronized with Two times harmonic of V_{sync} signal of system. Though PWM frequency is over 120Hz (max 252Hz), function of LED Driver is not affected.
- The duration of rush current is about 200ms. This duration is applied to LED on time.
- Even though inrush current is over the specified value, there is no problem if I²T spec of fuse is satisfied.
- Ext_PWM Signal have to input available duty range.
Between 99% and 100% ExtV_{BR-B} duty have to be avoided. ($99\% < \text{ExtV}_{BR-B} < 100\%$)
But ExtV_{BR-B} 0% and 100% is possible.
- The life time is determined as the time at which brightness of the LED is 50% compared to that of initial value at the typical LED current on condition of continuous operating at $25 \pm 2^\circ\text{C}$, based on duty 100%.

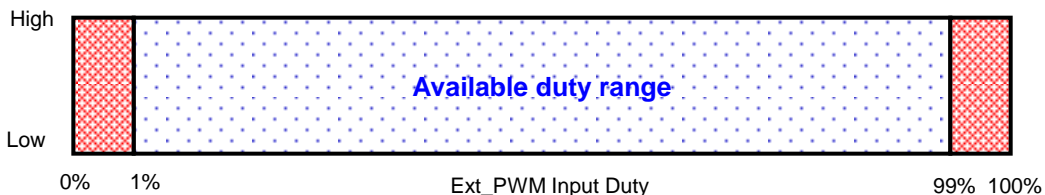

Product Specification

3-2. Interface Connections

This LCD module employs two kinds of interface connection, a 51-pin connector is used for the module electronics and Master 14-pin and Slave 12-pin connectors are used for the integral backlight system.

3-2-1. LCD Module

- LCD Connector(CN1): FI-RE51S-HF, Refer to below table.
- Mating Connector : FI-RE51HL

Table 4. MODULE CONNECTOR(CN1) PIN CONFIGURATION

No	Symbol	Description	No	Symbol	Description
1	Reverse	'H' = Reverse, 'L' = Forward	27	Bit Select	H' or NC= 10bit(D) , 'L' = 8bit
2	NC	No Connection	28	RE0N	SECOND LVDS Receiver Signal (A-)
3	NC	No Connection	29	RE0P	SECOND LVDS Receiver Signal (A+)
4	NC	No Connection (Reserved for LGD)	30	RE1N	SECOND LVDS Receiver Signal (B-)
5	NC	No Connection (Reserved for LGD)	31	RE1P	SECOND LVDS Receiver Signal (B+)
6	NC	No Connection (Reserved for LGD)	32	RE2N	SECOND LVDS Receiver Signal (C-)
7	LVDS Select	'H' =JEIDA , 'L' = VESA	33	RE2P	SECOND LVDS Receiver Signal (C+)
8	SCL	LED Driver Defect Detecting	34	GND	Ground
9	SDA	LED Driver Defect Detecting	35	RECLKN	SECOND LVDS Receiver Clock Signal(-)
10	Local Dimming	'H' =Enable only	36	RECLKP	SECOND LVDS Receiver Clock Signal(+)
11	GND	Ground	37	GND	Ground
12	RO0N	FIRST LVDS Receiver Signal (A-)	38	RE3N	SECOND LVDS Receiver Signal (D-)
13	RO0P	FIRST LVDS Receiver Signal (A+)	39	RE3P	SECOND LVDS Receiver Signal (D+)
14	RO1N	FIRST LVDS Receiver Signal (B-)	40	RE4N	SECOND LVDS Receiver Signal (E-)
15	RO1P	FIRST LVDS Receiver Signal (B+)	41	RE4P	SECOND LVDS Receiver Signal (E+)
16	RO2N	FIRST LVDS Receiver Signal (C-)	42	NC	No Connection
17	RO2P	FIRST LVDS Receiver Signal (C+)	43	NC	No Connection
18	GND	Ground	44	NC	No Connection
19	ROCLKN	FIRST LVDS Receiver Clock Signal(-)	45	GND	Ground
20	ROCLKP	FIRST LVDS Receiver Clock Signal(+)	46	GND	Ground
21	GND	Ground	47	GND	Ground
22	RO3N	FIRST LVDS Receiver Signal (D-)	48	VLCD	Power Supply +12.0V
23	RO3P	FIRST LVDS Receiver Signal (D+)	49	VLCD	Power Supply +12.0V
24	RO4N	FIRST LVDS Receiver Signal (E-)	50	VLCD	Power Supply +12.0V
25	RO4P	FIRST LVDS Receiver Signal (E+)	51	VLCD	Power Supply +12.0V
26	NC	No Connection	-	-	-

Notes:

1. All GND(ground) pins should be connected together to the LCD module's metal frame.
2. All VLCD (power input) pins should be connected together.
3. All Input levels of LVDS signals are based on the **EIA 644** Standard.
4. Specific pins(pin No. #2~#6) are used for internal data process of the LCD module.
These pins should be no connection.
5. It may be happened to Abnormal Display during the system interface signal is not
6. If Specific pin No. #7, #10, #27 is "NC" , LCD Module may be happened to Abnormal Display
- * Even when you use the reverse function, LCM can't be installed Reversed
7. Specially added pins #8 & #9, for LED Driver Defect Detecting (Appendix VIII)

Product Specification

3-2-2. Backlight Module

Master

-LED Driver Connector

: 20022WR-14B2(Yeonho) / 20022WR-12B2(Yeonho)

- Mating Connector

: 20022HS-14 / 20022HS-12

Table 5. LED DRIVER CONNECTOR PIN CONFIGURATION

Pin No	Symbol	Description	14PIN	12PIN	Note
1	VBL	Power Supply +24.0V	VBL	VBL	
2	VBL	Power Supply +24.0V	VBL	VBL	
3	VBL	Power Supply +24.0V	VBL	VBL	
4	VBL	Power Supply +24.0V	VBL	VBL	
5	VBL	Power Supply +24.0V	VBL	VBL	
6	GND	Backlight Ground	GND	GND	
7	GND	Backlight Ground	GND	GND	
8	GND	Backlight Ground	GND	GND	1
9	GND	Backlight Ground	GND	GND	
10	GND	Backlight Ground	GND	GND	
11	Status	Status	Status	NC	2
12	VON/OFF	Backlight ON/OFF control	VON/OFF	NC	
13	EXTVBR-B	External PWM	EXTVBR-B	-	3
14	NC	No connection	NC	-	1

Notes :1. GND should be connected to the LCD module's metal frame.

2. Normal : Low (under 0.7V) / Abnormal :Open

3. High : on duty / Low : off duty, Pin#13 can be opened. (if Pin #13 is open , EXTVBR-B is 100%)

4. Each impedance of pin #12 and #13 is over 50 [KΩ] .

◆ Rear view of LCM

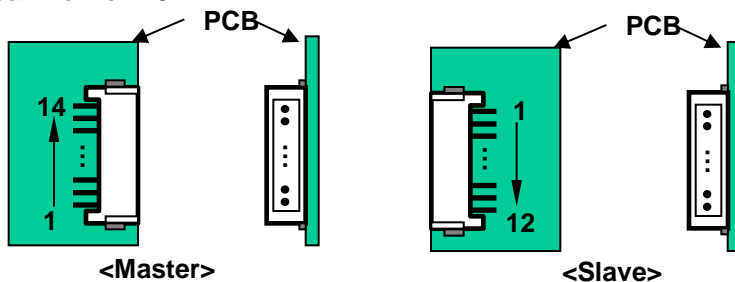

◆ Status

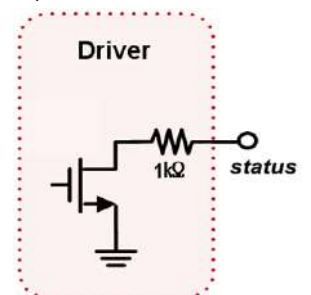

Product Specification

3-3. Signal Timing Specifications

Table 6 shows the signal timing required at the input of the LVDS transmitter. All of the interface signal timings should be satisfied with the following specification for normal operation.

Table 6. TIMING TABLE for NTSC & PAL (DE Only Mode)

ITEM		Symbol	Min	Typ	Max	Unit	notes
Horizontal	Display Period	tHV	960	960	960	tCLK	1920 / 2
	Blank	tHB	100	140	240	tCLK	1
	Total	tHP	1060	1100	1200	tCLK	
Vertical	Display Period	tVv	1080	1080	1080	Lines	
	Blank	tVB	20	45	300	Lines	1
	Total	tVP	1100	1125	1380	Lines	

ITEM		Symbol	Min	Typ	Max	Unit	notes
Frequency	DCLK	fCLK	63.00	74.25	78.00	MHz	
	Horizontal	fH	57.3	67.5	70	KHz	2
	Vertical	fV	47	60	63	Hz	2

Note: 1. The input of HSYNC & VSYNC signal does not have an effect on normal operation (DE Only Mode).
If you use spread spectrum of EMI, add some additional clock to minimum value for clock margin.

2. The performance of the electro-optical characteristics may be influenced by variance of the vertical refresh rate and the horizontal frequency

3. Spread Spectrum Rate (SSR) for 50kHz ~ 100kHz Modulation Frequency(FMOD) is calculated by $(7 - 0.06 \cdot F_{mod})$, where Modulation Frequency (FMOD) unit is KHz.
LVDS Receiver Spread spectrum Clock is defined as below figure

※ Timing should be set based on clock frequency.

Product Specification

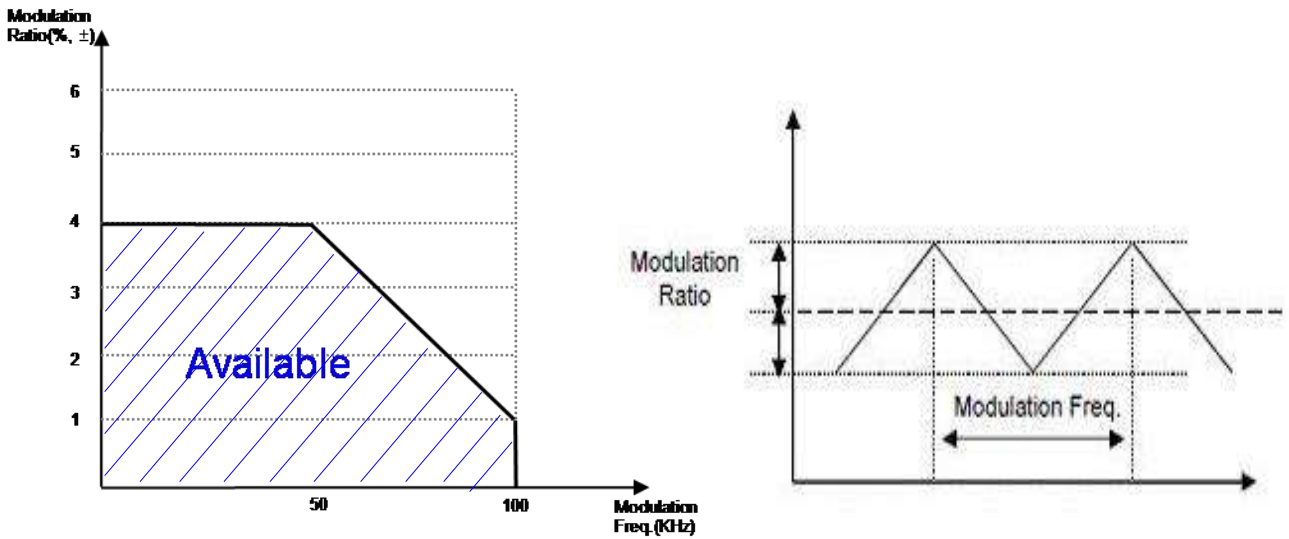

※ Please pay attention to the followings when you set Spread Spectrum Rate(SSR) and Modulation Frequency(FMOD)

1. Please set proper Spread Spectrum Rate(SSR) and Modulation Frequency (FMOD) of TV system LVDS output.
2. Please check FOS after you set Spread Spectrum Rate(SSR) and Modulation Frequency(FMOD) to avoid abnormal display. Especially, harmonic noise can appear when you use Spread Spectrum under FMOD 30 KHz.

3-4. LVDS Signal Specification

3-4-1. LVDS Input Signal Timing Diagram

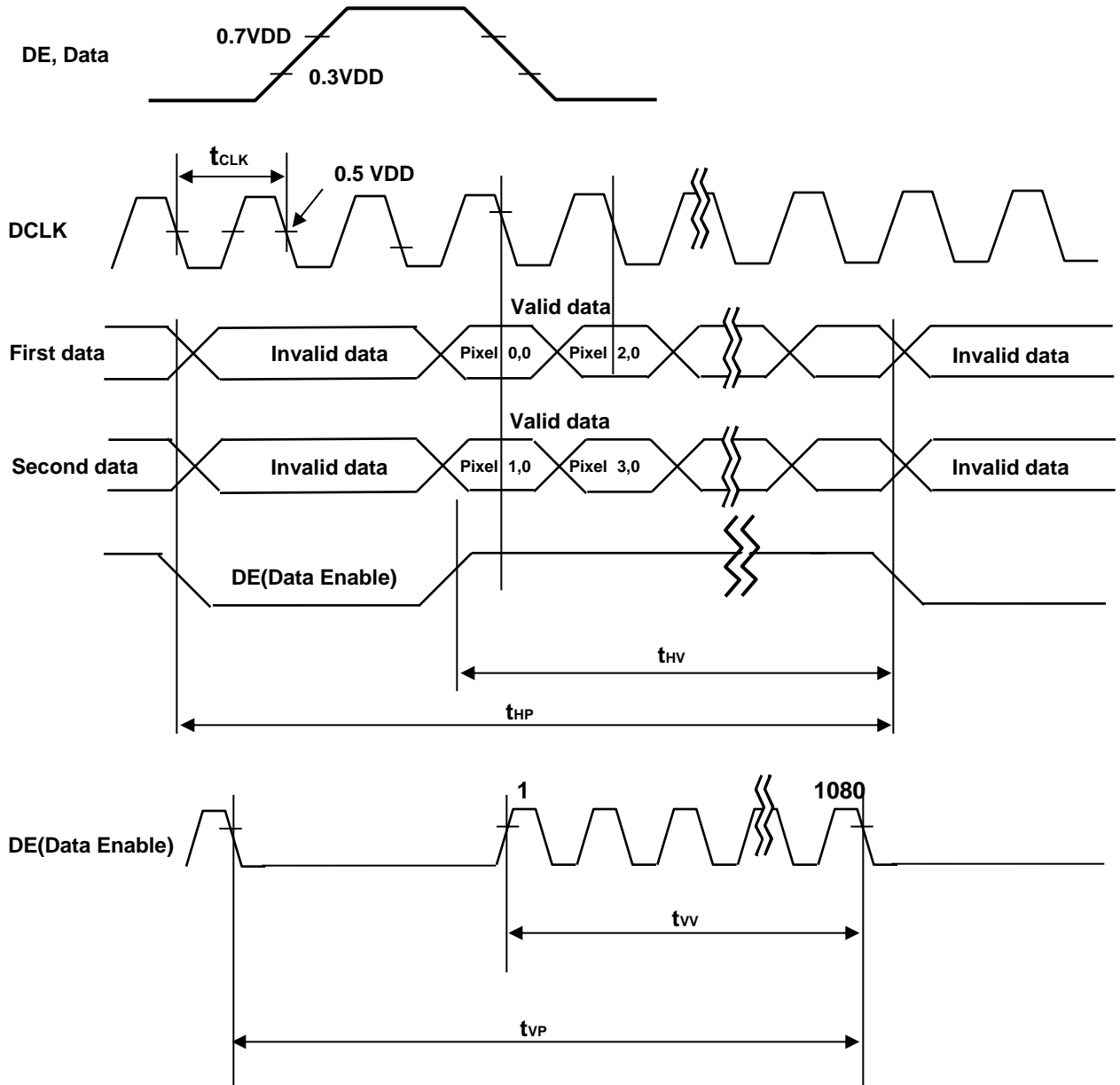

Product Specification

3-4-2. LVDS Input Signal Characteristics

1) DC Specification

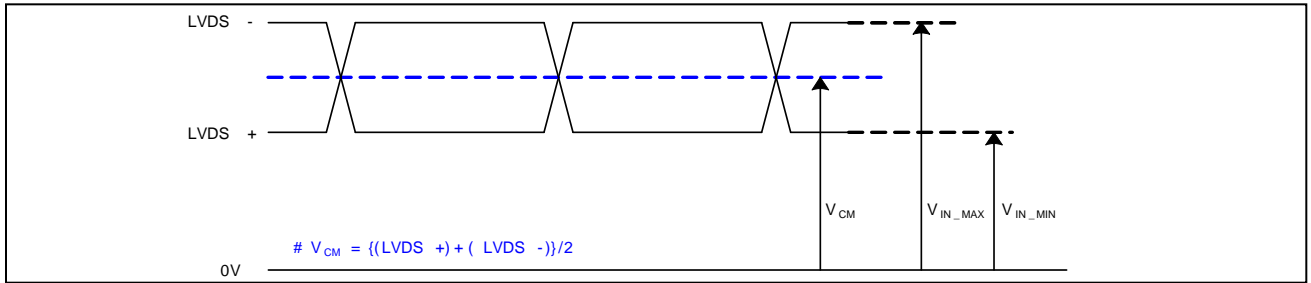

Description	Symbol	Min	Max	Unit	Note
LVDS Common mode Voltage	V_{CM}	1.0	1.5	V	-
LVDS Input Voltage Range	V_{IN}	0.7	1.8	V	-
Change in common mode Voltage	ΔV_{CM}		250	mV	-

2) AC Specification

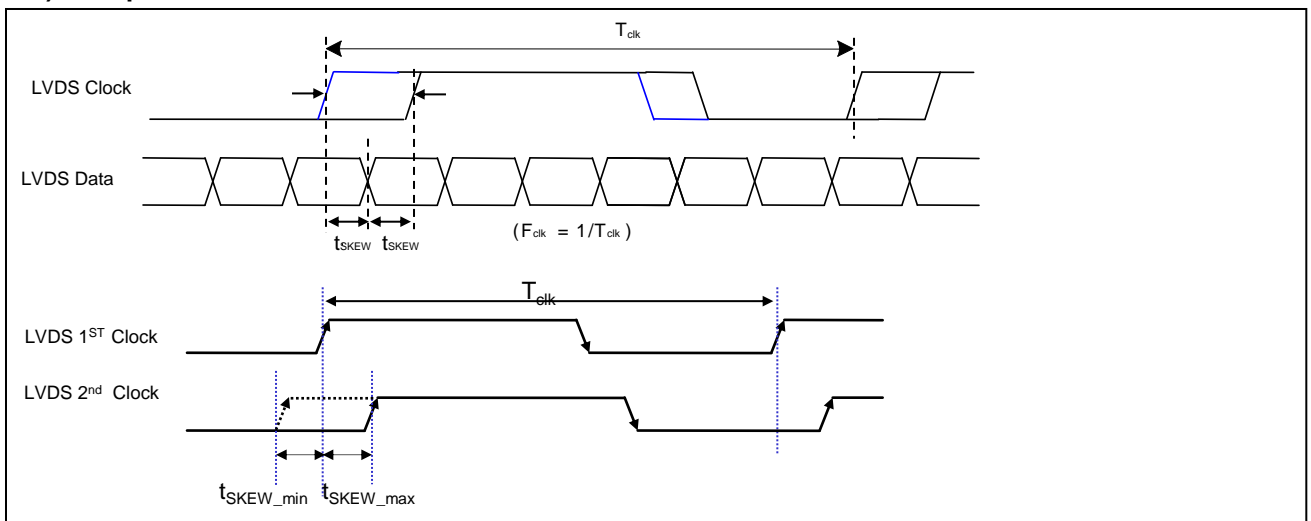

Description	Symbol	Min	Max	Unit	notes
LVDS Differential Voltage	V_{TH}	100	600	mV	Tested with Differential Probe 2
	V_{TL}	-600	-100	mV	
LVDS Clock to Data Skew	t_{SKEW}	-	$ (0.25 * T_{clk}) / 7 $	ps	-
Effective time of LVDS	t_{eff}	$ \pm 360 $	-	ps	-
LVDS Clock to Clock Skew (Even to Odd)	t_{SKEW_EO}	-	$ 1/7 * T_{clk} $	ps	-

Note 1. All Input levels of LVDS signals are based on the EIA 644 Standard.
 2. LVDS Differential Voltage is defined within t_{eff}

Product Specification

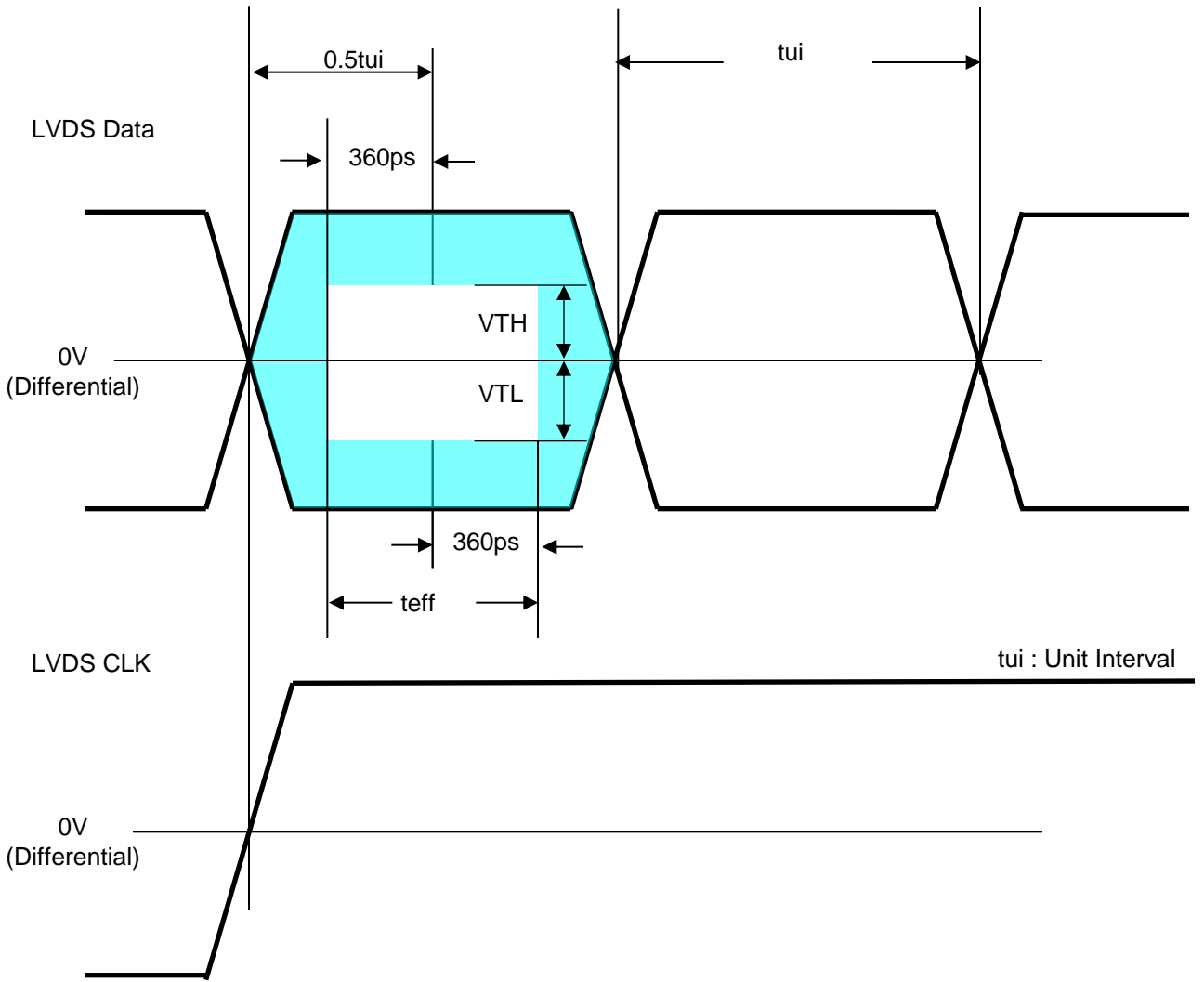

* This accumulated waveform is tested with differential probe

Product Specification

3-5. Color Data Reference

The brightness of each primary color(red,green,blue) is based on the 10-bit gray scale data input for the color. The higher binary input, the brighter the color. Table 8 provides a reference for color versus data input.

Table 7. COLOR DATA REFERENCE

Color		Input Color Data																													
		RED										GREEN										BLUE									
		MSB					LSB					MSB					LSB					MSB				LSB					
		R9	R8	R7	R6	R5	R4	R3	R2	R1	R0	G9	G8	G7	G6	G5	G4	G3	G2	G1	G0	B9	B8	B7	B6	B5	B4	B3	B2	B1	B0
Basic Color	Black	0	0	0	0	0	0	0	0	0	0	0	0	0	0	0	0	0	0	0	0	0	0	0	0	0	0	0	0	0	0
	Red (1023)	1	1	1	1	1	1	1	1	1	1	0	0	0	0	0	0	0	0	0	0	0	0	0	0	0	0	0	0	0	0
	Green(1023)	0	0	0	0	0	0	0	0	0	0	1	1	1	1	1	1	1	1	1	1	0	0	0	0	0	0	0	0	0	0
	Blue (1023)	0	0	0	0	0	0	0	0	0	0	0	0	0	0	0	0	0	0	0	0	1	1	1	1	1	1	1	1	1	1
	Cyan	0	0	0	0	0	0	0	0	0	0	1	1	1	1	1	1	1	1	1	1	1	1	1	1	1	1	1	1	1	1
	Magenta	1	1	1	1	1	1	1	1	1	1	0	0	0	0	0	0	0	0	0	0	1	1	1	1	1	1	1	1	1	1
	Yellow	1	1	1	1	1	1	1	1	1	1	1	1	1	1	1	1	1	1	1	1	0	0	0	0	0	0	0	0	0	0
	White	1	1	1	1	1	1	1	1	1	1	1	1	1	1	1	1	1	1	1	1	1	1	1	1	1	1	1	1	1	1
RED	RED (0000)	0	0	0	0	0	0	0	0	0	0	0	0	0	0	0	0	0	0	0	0	0	0	0	0	0	0	0	0	0	
	RED (0001)	0	0	0	0	0	0	0	0	0	1	0	0	0	0	0	0	0	0	0	0	0	0	0	0	0	0	0	0	0	0
									
	RED (1022)	1	1	1	1	1	1	1	1	1	0	0	0	0	0	0	0	0	0	0	0	0	0	0	0	0	0	0	0	0	0
	RED (1023)	1	1	1	1	1	1	1	1	1	1	0	0	0	0	0	0	0	0	0	0	0	0	0	0	0	0	0	0	0	0
GREEN	GREEN(0000)	0	0	0	0	0	0	0	0	0	0	0	0	0	0	0	0	0	0	0	0	0	0	0	0	0	0	0	0	0	
	GREEN(0001)	0	0	0	0	0	0	0	0	0	0	0	0	0	0	0	0	0	0	0	1	0	0	0	0	0	0	0	0	0	0
									
	GREEN(1022)	0	0	0	0	0	0	0	0	0	0	1	1	1	1	1	1	1	1	1	0	0	0	0	0	0	0	0	0	0	0
	GREEN(1023)	0	0	0	0	0	0	0	0	0	0	1	1	1	1	1	1	1	1	1	1	0	0	0	0	0	0	0	0	0	0
BLUE	BLUE (0000)	0	0	0	0	0	0	0	0	0	0	0	0	0	0	0	0	0	0	0	0	0	0	0	0	0	0	0	0	0	
	BLUE (0001)	0	0	0	0	0	0	0	0	0	0	0	0	0	0	0	0	0	0	0	0	0	0	0	0	0	0	0	0	1	
									
	BLUE (1022)	0	0	0	0	0	0	0	0	0	0	0	0	0	0	0	0	0	0	0	0	1	1	1	1	1	1	1	1	0	0
	BLUE (1023)	0	0	0	0	0	0	0	0	0	0	0	0	0	0	0	0	0	0	0	0	1	1	1	1	1	1	1	1	1	1

3-6. Power Sequence

3-6-1. LCD Driving circuit

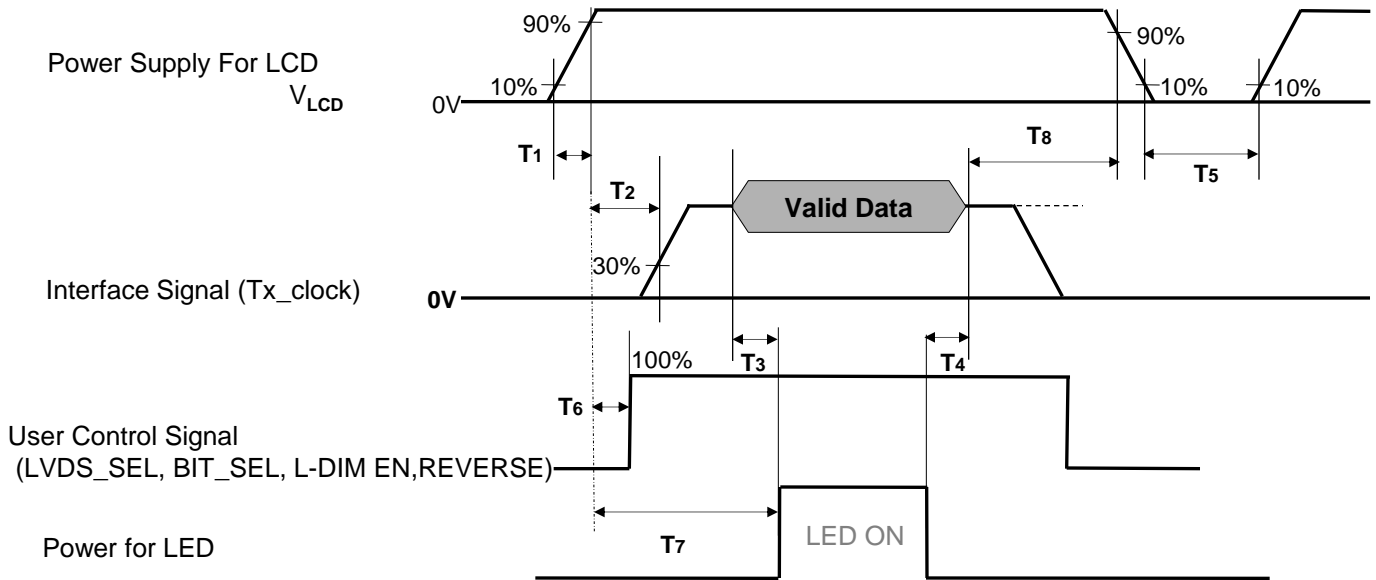
Table 8. POWER SEQUENCE

Parameter	Value			Unit	Notes
	Min	Typ	Max		
T1	0.5	-	20	ms	1
T2	0	-	-	ms	2
T3	200	-	-	ms	3
T4	200	-	-	ms	3
T5	1.0	-	-	s	4
T6	0	-	T2	ms	5
T7	0.5	-	-	s	6
T8	100	-	-	ms	7

- notes :
- Even though T1 is over the specified value, there is no problem if I2T spec of fuse is satisfied.
 - If T2 is satisfied with specification after removing LVDS Cable, there is no problem.
 - The T3 / T4 is recommended value, the case when failed to meet a minimum specification, abnormal display would be shown. There is no reliability problem.
 - T5 should be measured after the Module has been fully discharged between power off and on period.
 - If the on time of signals (Interface signal and user control signals) precedes the on time of Power (V_{LCD}), it will be happened abnormal display. When T6 is NC status, T6 doesn't need to be measured.
 - If there is no abnormal display, no problem.
 - It is recommendation specification that T8 has to be 100ms as a minimum value.
- ※ Please avoid floating state of interface signal at invalid period.
 - ※ When the power supply for LCD (V_{LCD}) is off, be sure to pull down the valid and invalid data to 0V.

Product Specification

3-6-2. Sequence for LED Driver

Power Supply For LED Driver

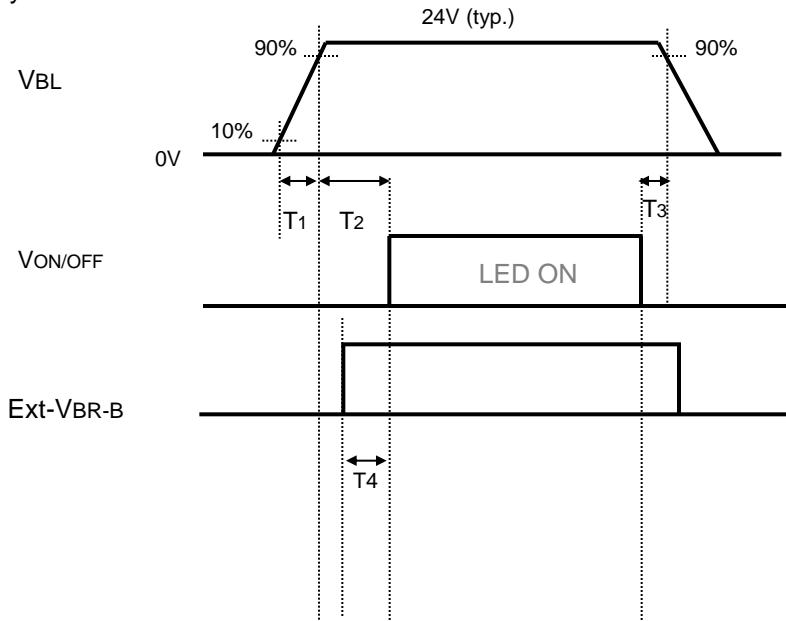

3-6-3. Deep condition for LED Driver

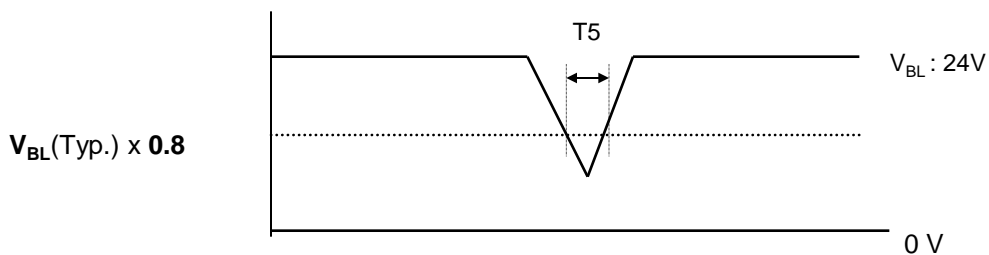

Table 9. Power Sequence for LED DRIVER

Parameter	Values			Units	Remarks
	Min	Typ	Max		
T1	20	-	-	ms	1
T2	500	-	-	ms	
T3	10	-	-	ms	
T4	0	-	-	ms	
T5	-	-	10	ms	$V_{BL}(Typ.) \times 0.8$

Notes : 1. T1 describes rising time of 0V to 24V and this parameter does not applied at restarting time. Even though T1 is over the specified value, there is no problem if I²T spec of fuse is satisfied.

Product Specification

4. Optical Specification

Optical characteristics are determined after the unit has been 'ON' and stable in a dark environment at $25 \pm 2^\circ\text{C}$. The values specified are at an approximate distance 50cm from the LCD surface at a viewing angle of Φ and θ equal to 0° .

FIG. 1 shows additional information concerning the measurement equipment and method.

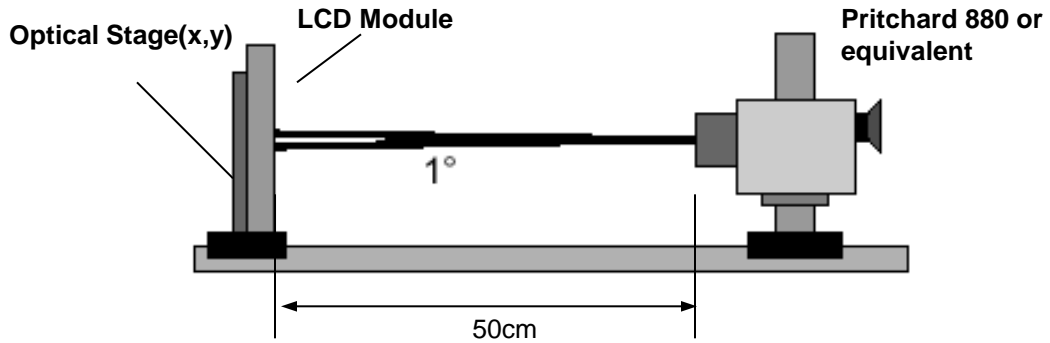

FIG. 1 Optical Characteristic Measurement Equipment and Method

$T_a = 25 \pm 2^\circ\text{C}$, $V_{\text{LCD}} = 12.0\text{V}$, $f_v = 60\text{Hz}$,
 $\text{Dclk} = 74.25\text{MHz}$, Ext VBR-B=100%

Table 10. OPTICAL CHARACTERISTICS

Parameter	Symbol	Value			Unit	Note		
		Min	Typ	Max				
Contrast Ratio	CR	800	1100	-		1		
Dynamic Contrast Ratio	DCR	20000	30000	-		8		
Surface Luminance, white	L_{WH}	560	700	-	cd/m ²	2		
Luminance Variation	δ_{WHITE} 13P	80	90	-		3		
Response Time	Gray-to-Gray	G to G	-	8	12	ms	4	
Color Coordinates [CIE1931]	RED	Rx	Typ -0.03	0.647	Typ +0.03			
		Ry		0.331				
	GREEN	Gx		0.313				
		Gy		0.609				
	BLUE	Bx		0.154				
		By		0.056				
	WHITE	Wx		Typ -0.02		0.279	Typ +0.02	
		Wy		0.292				
Color Temperature			10,000		K			
Color Gamut			72		%			
Half Luminance Angle								
	Horizontal	$\Theta_{r,l}$	50	-	-	degree	5	
	Vertical	$\Theta_{u,d}$	50	-	-			
Viewing Angle (CR>10)								
	x axis, right($\phi=0^\circ$)	θ_r	89	-	-	degree	6	
	x axis, left ($\phi=180^\circ$)	θ_l	89	-	-			
	y axis, up ($\phi=90^\circ$)	θ_u	89	-	-			
	y axis, down ($\phi=270^\circ$)	θ_d	89	-	-			
Gray Scale			-	-	-		7	

Product Specification

Notes :1. Contrast Ratio(CR) is defined mathematically as :

$$CR(\text{Contrast Ratio}) = \text{Maximum CR}_n (n=1, 2, 3, 4, 5)$$

$$CR_n = \frac{\text{Surface Luminance at position } n \text{ with all white pixels}}{\text{Surface Luminance at position } n \text{ with all black pixels}}$$

n = the Position number(1, 2, 3, 4, 5). For more information, see FIG 2.

2. Surface luminance are determined after the unit has been 'ON' and 60min after lighting the backlight in a dark environment at $25 \pm 2^\circ\text{C}$. Surface luminance is the luminance value at center 1-point across the LCD surface 50cm from the surface with all pixels displaying white. For more information see the FIG. 2.
3. δ WHITE(13P) = $\frac{\text{Minimum}(\text{Lon1}, \text{Lon2}, \text{Lon3}, \dots, \text{Lon13})}{\text{Maximum}(\text{Lon1}, \text{Lon2}, \text{Lon3}, \dots, \text{Lon13})} * 100(\%)$
 Where Lon1 to Lon9 are the luminance with all pixels displaying white at 9 locations .
 For more information, see the FIG. 2-2.
4. Response time is the time required for the display to transition from G(N) to G(M) (Rise Time, Tr_R) and from G(M) to G(N) (Decay Time, Tr_D). For additional information see the FIG. 3. (N<M)
 ※ G to G Spec is average of measured time (N, M = 0 (Black) ~ 1023(White), 128 gray step).
5. Viewing angle is the angle at which the contrast ratio is greater than 10. The angles are determined for the horizontal or x axis and the vertical or y axis with respect to the z axis which is normal to the LCD module surface. For more information, see the FIG. 4.
 Half Luminance Angle is the angle over the middle brightness 50%
6. Half Luminance Angle is a angle of half luminance compare to center luminance at 255 gray.
 For more information, see the FIG. 4
7. Gray scale specification
 Gamma Value is approximately 2.2. For more information, see the Table 11.
8. Dynamic Contrast Ratio(DCR) is defined mathematically as : L_w / L_k
 -. L_w : White Center Pattern
 -. L_k : Black Center Pattern
 Use the corner-box pattern for local dimming measurements , For more information, see the FIG. 5

Table 11. GRAY SCALE SPECIFICATION

Gray Level	Luminance [%] (Typ.)
L0	0.07
L63	0.27
L127	1.04
L191	2.49
L255	4.68
L319	7.66
L383	11.5
L447	16.1
L511	21.6
L575	28.1
L639	35.4
L703	43.7
L767	53.0
L831	63.2
L895	74.5
L959	86.7
L1023	100

Measuring point for surface luminance & measuring point for luminance variation.

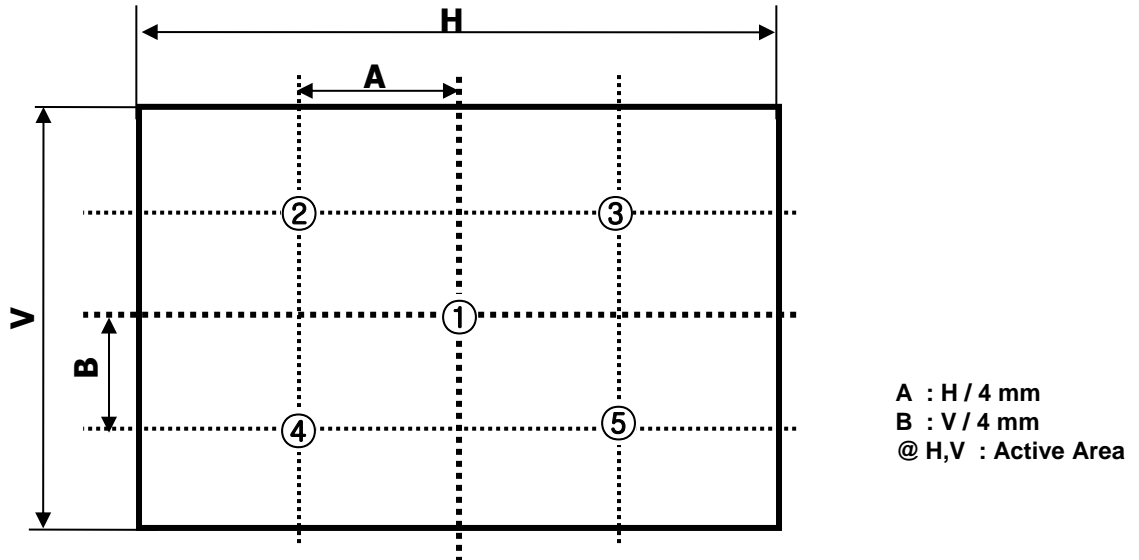

FIG. 2 5 Points for Luminance Measure

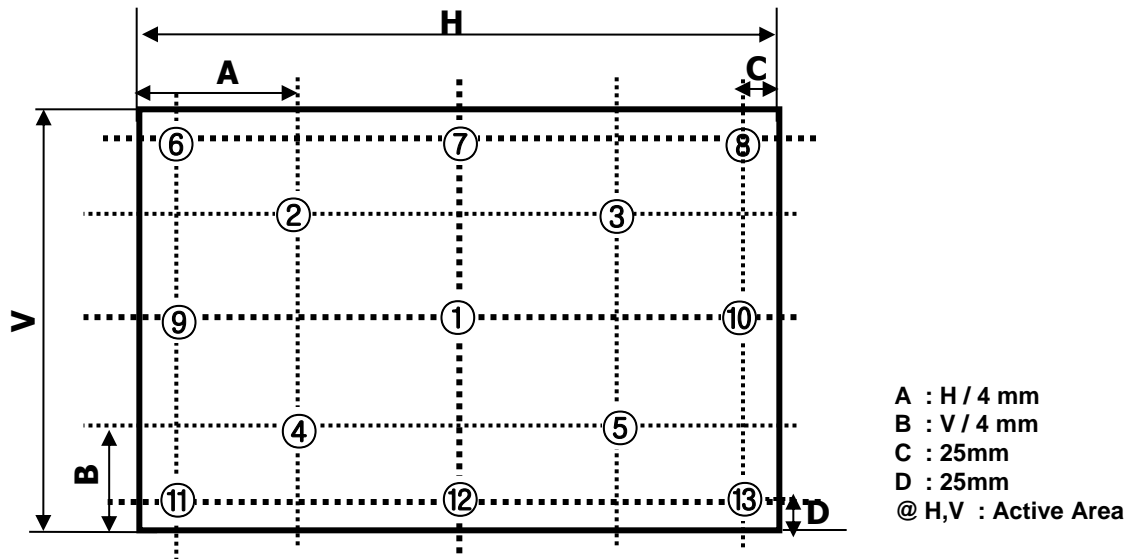

FIG. 2-2 13 Points for Luminance Measure

Product Specification

Response time is defined as the following figure and shall be measured by switching the input signal for “Gray(N)” and “Gray(M)”.

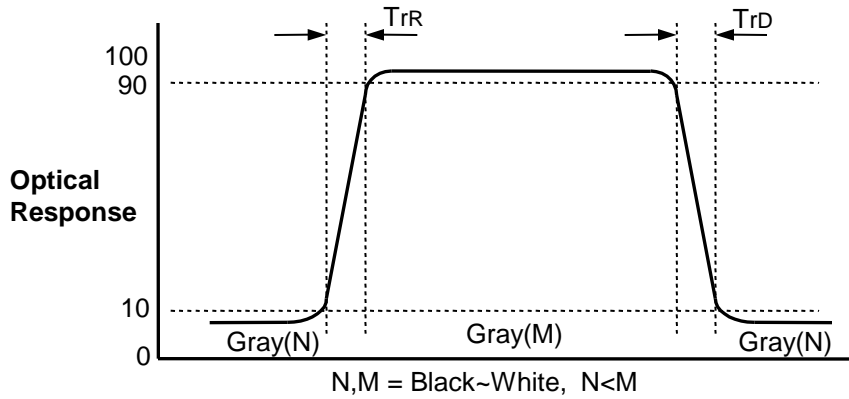

FIG. 3 Response Time

Dimension of viewing angle range

Half Luminance Angle : The angle of 50% luminance compare to normal direction luminance

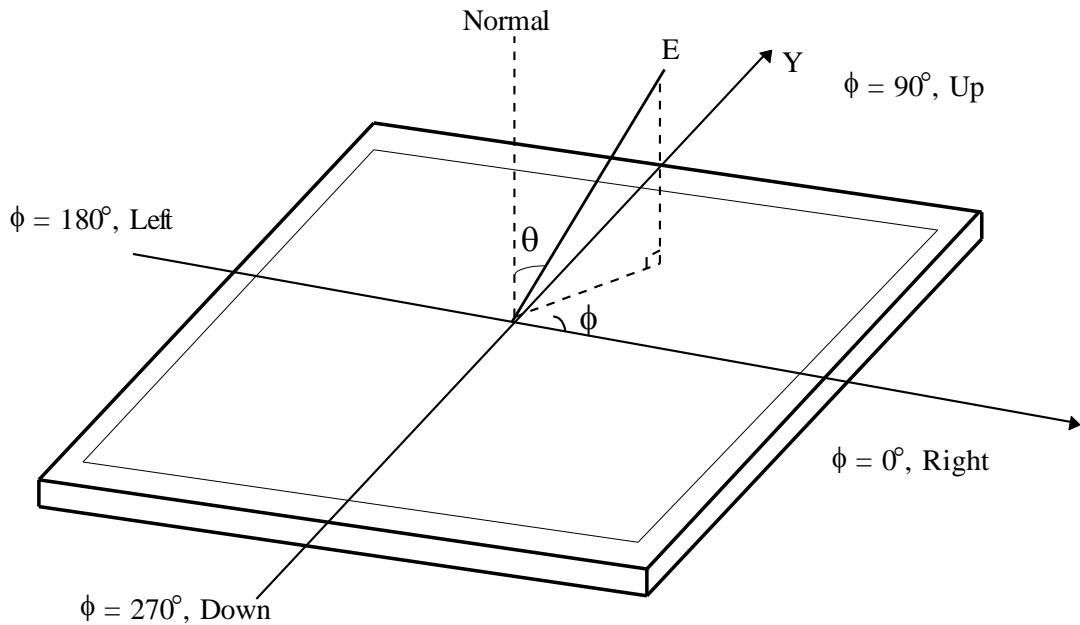

FIG. 4 Viewing Angle

Product Specification

Use the corner-box pattern for local dimming measurements.

We measure the center contrast of a 1/5 size white box compared to four 1/10 size boxes placed in each corner.

Measure the luminance L_w of the white-center pattern.
 Measure the luminance L_k of the black-center pattern.

Calculate $DCR = L_w / L_k$.

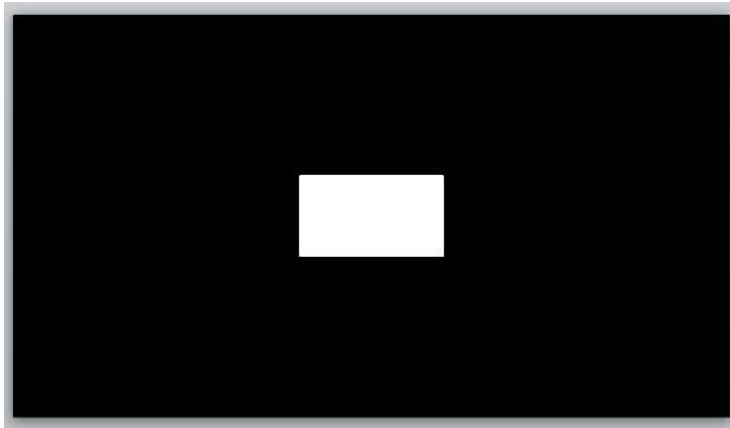

White center measurement is made on 20% linear box ; L_w
 (1/5 size of H and V of display)

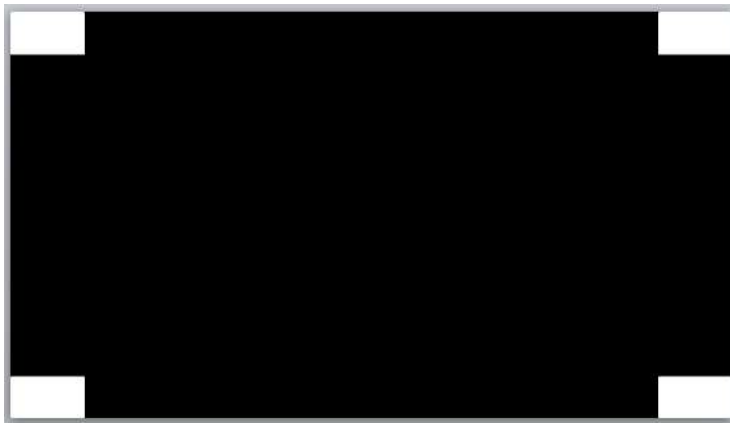

Black center measurement is made with 10% linear boxes in corners ; L_k
 (1/10 size of H and V of display)

FIG. 5 DCR Measurement Pattern

5. Mechanical Characteristics

Table 12 provides general mechanical characteristics.

Table 12. MECHANICAL CHARACTERISTICS

Item	Value	
Outline Dimension	Horizontal	1210.51 mm
	Vertical	681.22 mm
	Depth	53.3 mm
Active Display Area	Horizontal	1209.63 mm
	Vertical	680.34 mm
Weight	12.5kg (Typ.), 12.9kg (Max.)	

Note : Please refer to a mechanic drawing in terms of tolerance at the next page.

Product Specification

[FRONT VIEW]

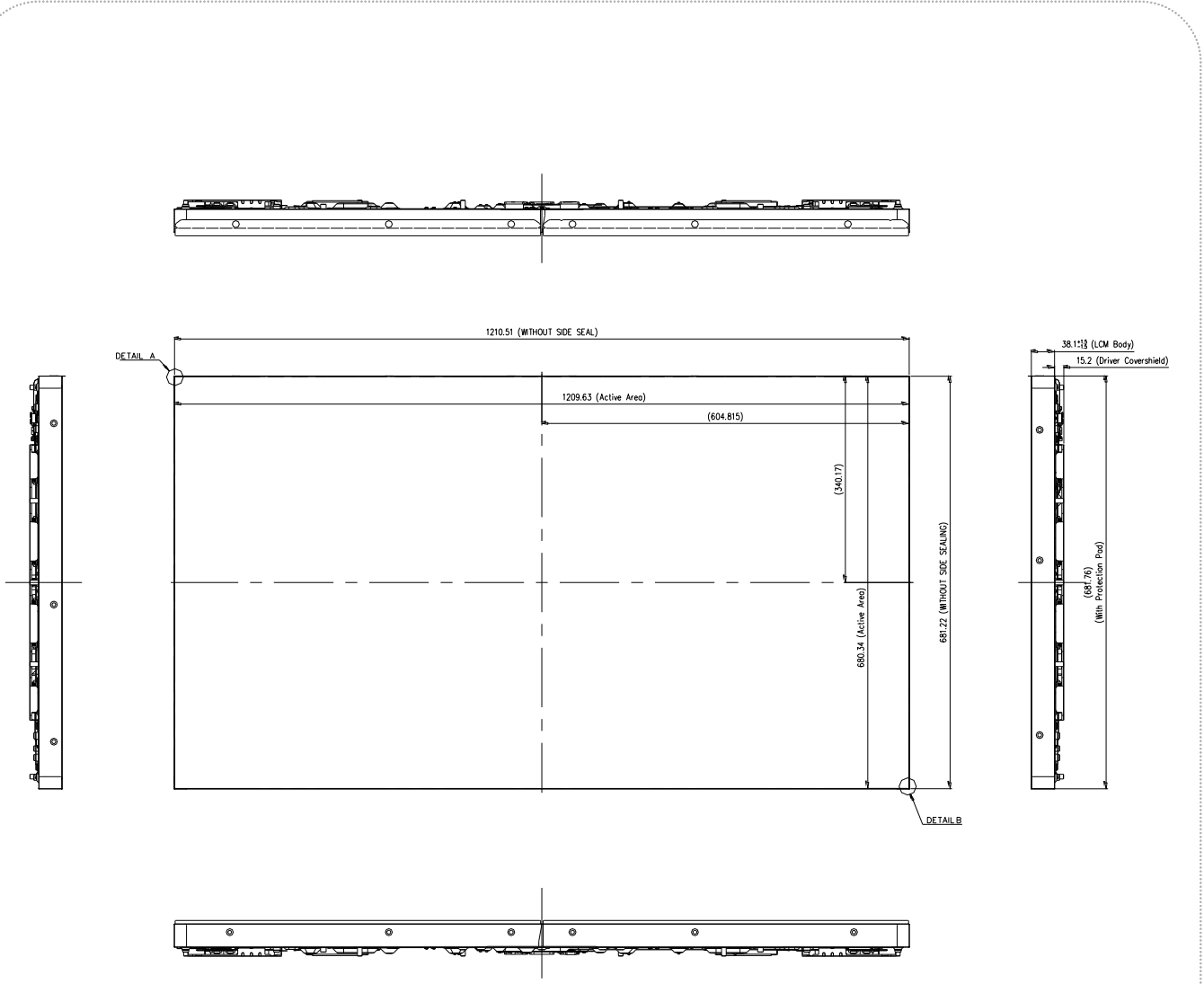

NOTES

1. Unspecified tolerance is ± 1.0 .
2. Side seal thickness about
A: 0.11mm, B: 0.05mm
3. Max Torque : refer to the table
4. Max Depth : refer to the table
5. Same figure means the same dimension.
6. Don't peel off black circle tapes and don't use screw hole at 4 sides.

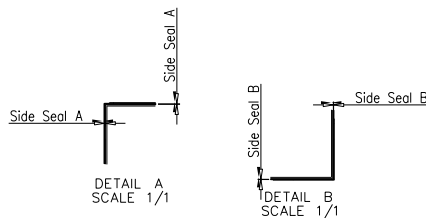

Date	Version
2018.03.28	0.0
2018.08.15	0.1
2018.09.18	0.2
2018.10.02	0.3
2018.11.16	0.4

Product Specification

<REAR VIEW>

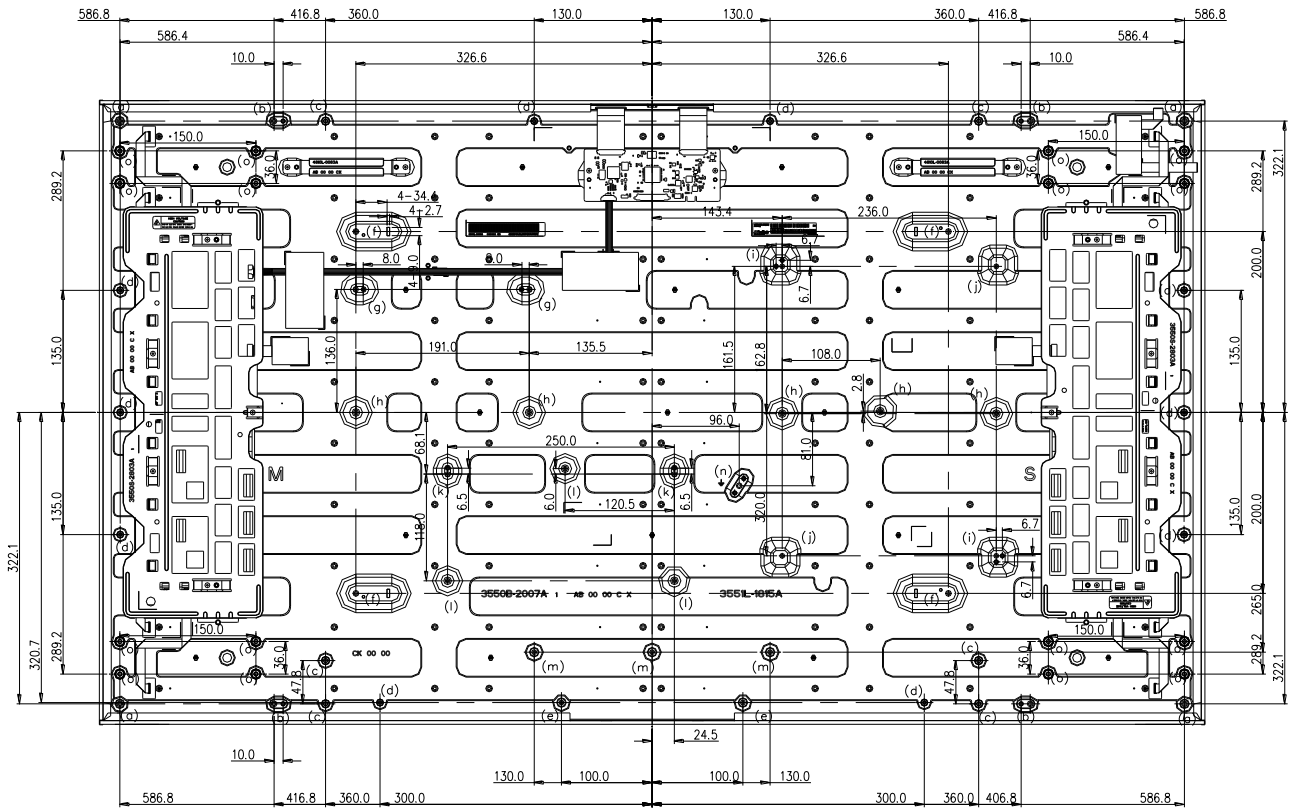

Date	Version
2018.03.28	0.0
2018.08.15	0.1
2018.09.18	0.2
2018.10.02	0.3
2018.11.16	0.4

Item	tap	Height from Body	Depth	torque	note
(a)	M 4.0	4.0mm	Max 3.7	Max 10kgf.cm	Emboes
(b)	M 4.0	4.0mm	Max 3.7	Max 10kgf.cm	Emboes
(c)	M 4.0	8.5mm	Max 5.5	Max 10kgf.cm	Pennut
(d)	M 3.0	15.0mm	Max 7.0	Max 6kgf.cm	Pennut
(e)	M 3.0	4.5mm	Max 5.4	Max 6kgf.cm	Emboes
(f)	M 4.0	10.3mm	Max 9.5	Max 10kgf.cm	Emboes
(g)	M 3.0	11.0mm	Max 10.0	Max 6kgf.cm	Emboes
(h)	M 3.0	11.0mm	Max 10.0	Max 6kgf.cm	Emboes
(i)	M 3.0	11.0mm	Max 10.0	Max 6kgf.cm	Emboes
(j)	M 3.0	11.0mm	Max 10.0	Max 6kgf.cm	Emboes
(k)	M 3.0	9.7mm	Max 9.0	Max 6kgf.cm	Emboes
(l)	M 3.0	9.7mm	Max 9.0	Max 6kgf.cm	Emboes
(m)	M 3.0	4.5mm	Max 5.4	Max 6kgf.cm	Emboes
(n)	M 4.0	6.0mm	Max 5.5	Max 10kgf.cm	Emboes
(o)	M 4.0	8.5mm	Max 5.5	Max 10kgf.cm	Pennut

6. Reliability

Table 13. ENVIRONMENT TEST CONDITION

No.	Test Item	Condition
1	High temperature storage test	Ta= 60°C 90%, 240h
2	Low temperature storage test	Ta= -20°C 240h
3	High temperature operation test	Ta= 50°C 50%RH 500h
4	Low temperature operation test	Ta= 0°C 500h
5	Humidity condition Operation	Ta= 40 °C ,90%RH
6	Altitude operating storage / shipment	0 - 16,400 ft 0 - 40,000 ft

Note : Before and after Reliability test, LCM should be operated with normal function.

7. International Standards

7-1. Safety

- a) UL 60950-1, Underwriters Laboratories Inc.
Information Technology Equipment - Safety - Part 1 : General Requirements.
- b) CAN/CSA-C22.2 No. 60950-1-07, Canadian Standards Association.
Information Technology Equipment - Safety - Part 1 : General Requirements.
- c) EN 60950-1, European Committee for Electrotechnical Standardization (CENELEC).
Information Technology Equipment - Safety - Part 1 : General Requirements.
- d) IEC 60950-1, The International Electrotechnical Commission (IEC).
Information Technology Equipment - Safety - Part 1 : General Requirements

7-2. Environment

- a) RoHS, Directive 2011/65/EU of the European Parliament and of the council of 8 June 2011

Product Specification

8. Packing

8-1. Information of LCM Label

a) Lot Mark

A	B	C	D	E	F	G	H	I	J	K	L	M
---	---	---	---	---	---	---	---	---	---	---	---	---

A,B,C : SIZE(INCH)
E : MONTH

D : YEAR
F ~ M : SERIAL NO.

Note

1. YEAR

Year	2011	2012	2013	2014	2015	2016	2017	2018	2019	2020
Mark	A	B	C	D	E	F	G	H	J	K

2. MONTH

Month	Jan	Feb	Mar	Apr	May	Jun	Jul	Aug	Sep	Oct	Nov	Dec
Mark	1	2	3	4	5	6	7	8	9	A	B	C

b) Location of Lot Mark

Serial No. is printed on the label. The label is attached to the backside of the LCD module.
This is subject to change without prior notice.

8-2. Packing Form

a) Package quantity in one box : 10 pcs

b) Pallet Assy Size : 1440mm(W) X 1140mm(D) X 950mm(H)

Product Specification

9. Precautions

Please pay attention to the followings when you use this TFT LCD module.

9-1. Mounting Precautions

- (1) You must mount a module using specified mounting holes (Details refer to the drawings).
- (2) You should consider the mounting structure so that uneven force (ex. Twisted stress) is not applied to the module. And the case on which a module is mounted should have sufficient strength so that external force is not transmitted directly to the module.
- (3) Please attach the surface transparent protective plate to the surface in order to protect the polarizer. Transparent protective plate should have sufficient strength in order to resist external force.
- (4) You should adopt radiation structure to satisfy the temperature specification.
- (5) Acetic acid type and chlorine type materials for the cover case are not desirable because the former generates corrosive gas of attacking the polarizer at high temperature and the latter causes circuit break by electro-chemical reaction.
- (6) Do not touch, push or rub the exposed polarizers with glass, tweezers or anything harder than HB pencil lead. And please do not rub with dust clothes with chemical treatment.
Do not touch the surface of polarizer for bare hand or greasy cloth.(Some cosmetics are detrimental to the polarizer.)
- (7) When the surface becomes dusty, please wipe gently with absorbent cotton or other soft materials like chamois soaks with petroleum benzine. Normal-hexane is recommended for cleaning the adhesives used to attach front / rear polarizers. Do not use acetone, toluene and alcohol because they cause chemical damage to the polarizer.
- (8) Wipe off saliva or water drops as soon as possible. Their long time contact with polarizer causes deformations and color fading.
- (9) Do not open the case because inside circuits do not have sufficient strength.

9-2. Operating Precautions

- (1) The spike noise causes the mis-operation of circuits. It should be lower than following voltage :
 $V = \pm 200\text{mV}$ (Over and under shoot voltage)
- (2) Response time depends on the temperature. (In lower temperature, it becomes longer.)
- (3) Brightness depends on the temperature. (In lower temperature, it becomes lower.)
And in lower temperature, response time (required time that brightness is stable after turned on) becomes longer
- (4) Be careful for condensation at sudden temperature change. Condensation makes damage to polarizer or electrical contacted parts. And after fading condensation, smear or spot will occur.
- (5) When fixed patterns are displayed for a long time, remnant image is likely to occur.
- (6) Module has high frequency circuits. Sufficient suppression to the electromagnetic interference shall be done by system manufacturers. Grounding and shielding methods may be important to minimized the interference.
- (7) Please do not give any mechanical and/or acoustical impact to LCM. Otherwise, LCM can't be operated its full characteristics perfectly.
- (8) A screw which is fastened up the steels should be a machine screw.
(if not, it can causes conductive particles and deal LCM a fatal blow)
- (9) Please do not set LCD on its edge.
- (10) The conductive material and signal cables are kept away from LED driver inductor to prevent abnormal display, sound noise and temperature rising.

9-3. Electrostatic Discharge Control

Since a module is composed of electronic circuits, it is not strong to electrostatic discharge. Make certain that treatment persons are connected to ground through wrist band etc. And don't touch interface pin directly.

9-4. Precautions for Strong Light Exposure

Strong light exposure causes degradation of polarizer and color filter.

9-5. Storage

When storing modules as spares for a long time, the following precautions are necessary.

- (1) Store them in a dark place. Do not expose the module to sunlight or fluorescent light. Keep the temperature between 5°C and 35°C at normal humidity.
- (2) The polarizer surface should not come in contact with any other object.
It is recommended that they be stored in the container in which they were shipped.

9-6. Handling Precautions for Protection Film

- (1) The protection film is attached to the bezel with a small masking tape.
When the protection film is peeled off, static electricity is generated between the film and polarizer.
This should be peeled off slowly and carefully by people who are electrically grounded and with well ion-blown equipment or in such a condition, etc.
- (2) When the module with protection film attached is stored for a long time, sometimes there remains a very small amount of glue still on the bezel after the protection film is peeled off.
- (3) You can remove the glue easily. When the glue remains on the bezel surface or its vestige is recognized, please wipe them off with absorbent cotton waste or other soft material like chamois soaked with normal-hexane.

9-7. Appropriate Condition for commercial Display

- Generally large-sized LCD modules are designed for consumer applications (TV).
Accordingly, a long-term display like in commercial Display (PD) application, can cause uneven display including image sticking. To optimize module's lifetime and function, several operating usages are required.

1. Normal operating condition

- Temperature: 0 ~ 40 °C
 - Operating Ambient Humidity : 10 ~ 90 %
 - Display pattern: dynamic pattern (Real display)
- Note) Long-term static display can cause image sticking.
- . Be careful for expose the module to sunlight. It causes degradation of polarizer and color filter.

2. Operating usages under abnormal condition

- a. Ambient condition
 - Well-ventilated place is recommended to set up PD system.
- b. Power and screen save
 - Periodical power-off or screen save is needed after long-term display.

Product Specification

3. Operating usages to protect against image sticking due to long-term static display
 - a. Suitable operating time: under 24 hours a day.
 - b. Static information display recommended to use with moving image.
 - Cycling display between 5 minutes' information(static) display and 10 seconds' moving image.
 - c. Background and character (image) color change
 - Use different colors for background and character, respectively.
 - Change colors themselves periodically.
 - d. Avoid combination of background and character with large different luminance.
 - 1) Abnormal condition just means conditions except normal condition.
 - 2) Black image or moving image is strongly recommended as a screen save.
4. Lifetime in this spec. is guaranteed only when PD is used according to operating usages.
 5. Module should be turned clockwise based on front view when used in portrait mode.

APPENDIX-I-1

■ Required signal assignment for Flat Link (Thine : THC63LVD103) Transmitter(Pin7="L or NC")

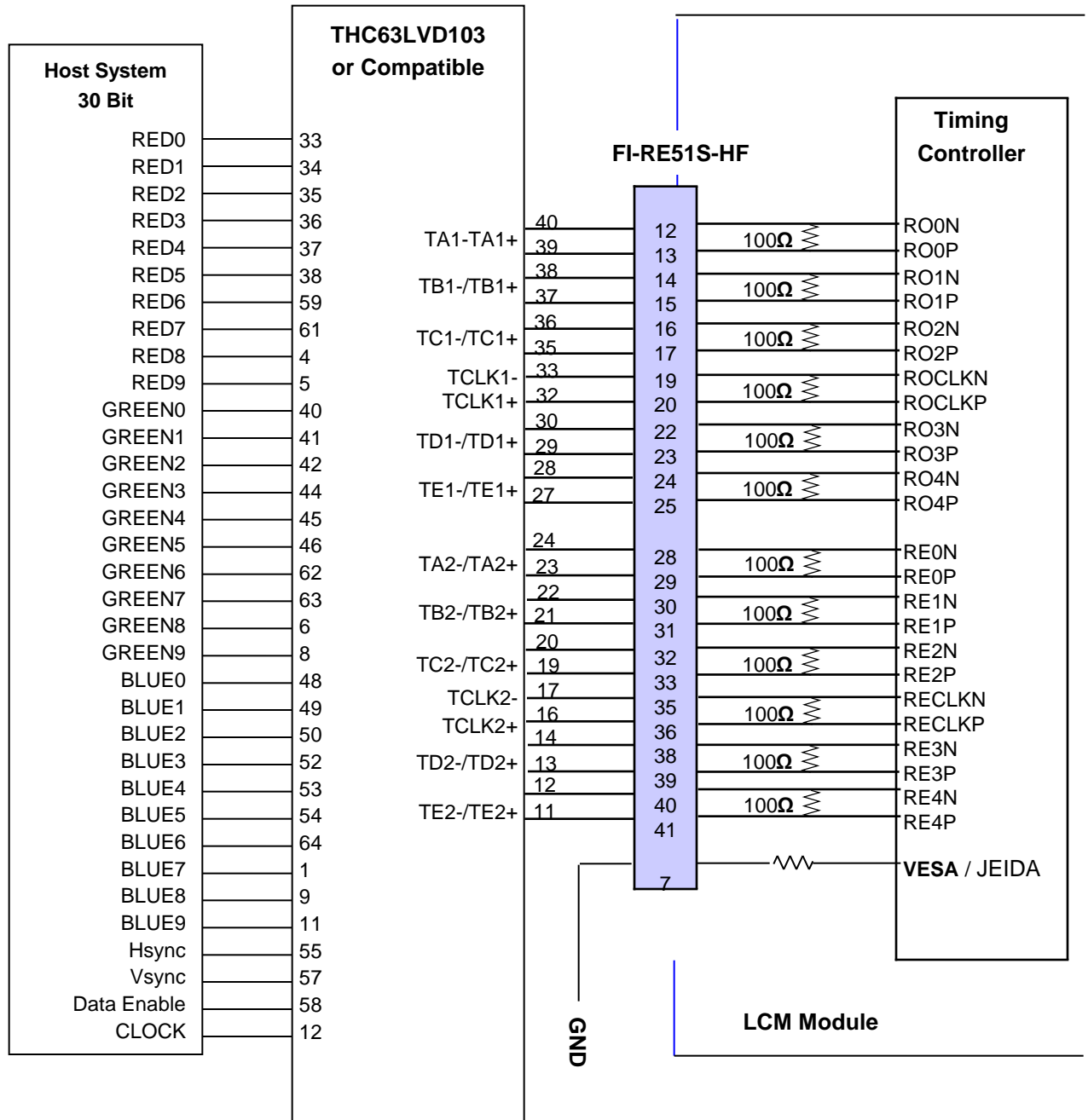

Note: 1. The LCD module uses a 100 Ohm[Ω] resistor between positive and negative lines of each receiver input.

2. Refer to LVDS Transmitter Data Sheet for detail descriptions. (THC63LVD103 or Compatible)

3. '9' means MSB and '0' means LSB at R,G,B pixel data.

APPENDIX-I-2

Required signal assignment for Flat Link (Thine : THC63LVD103) Transmitter(Pin7="H")

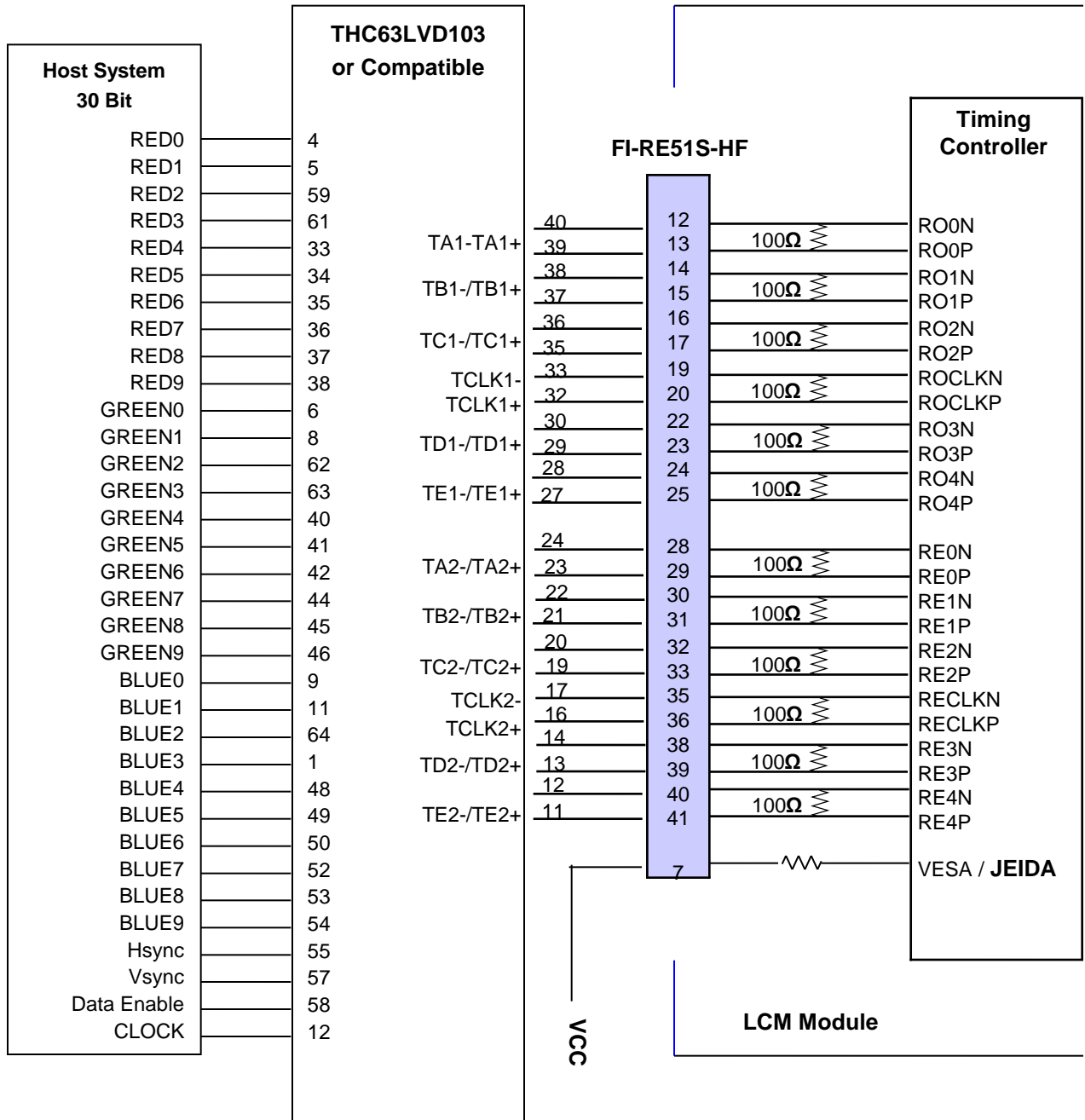

- Note :1. The LCD module uses a 100 Ohm[Ω] resistor between positive and negative lines of each receiver input.
 2. Refer to LVDS Transmitter Data Sheet for detail descriptions. (THC63LVD103 or Compatible)
 3. '9' means MSB and '0' means LSB at R,G,B pixel data.

APPENDIX- II

LVDS Data-Mapping info. (10bit)

■ LVDS Select : "H" Data-Mapping (JEIDA format)

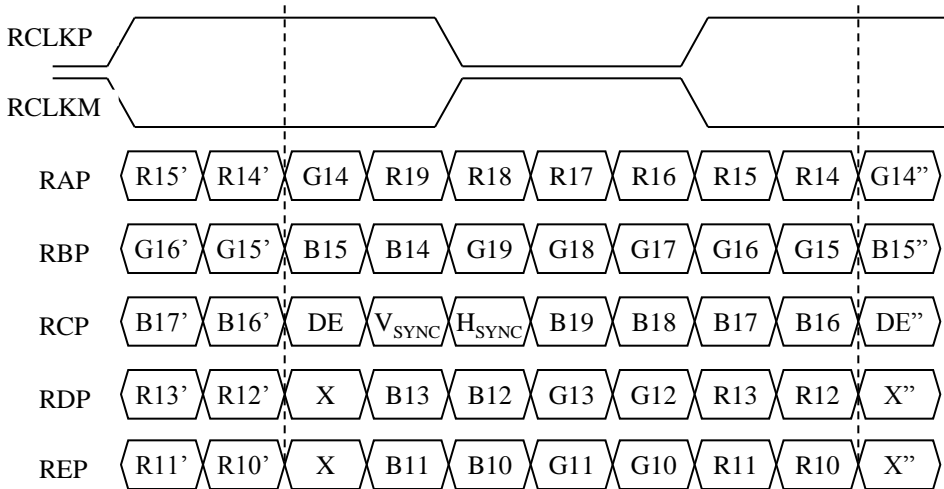

■ LVDS Select : "L" Data-Mapping (VESA format)

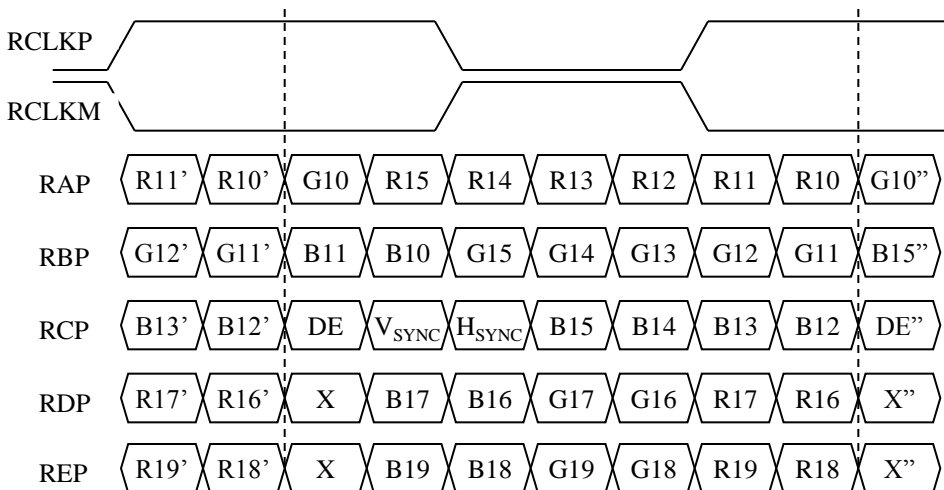

APPENDIX-III

■ Pallet Ass'y

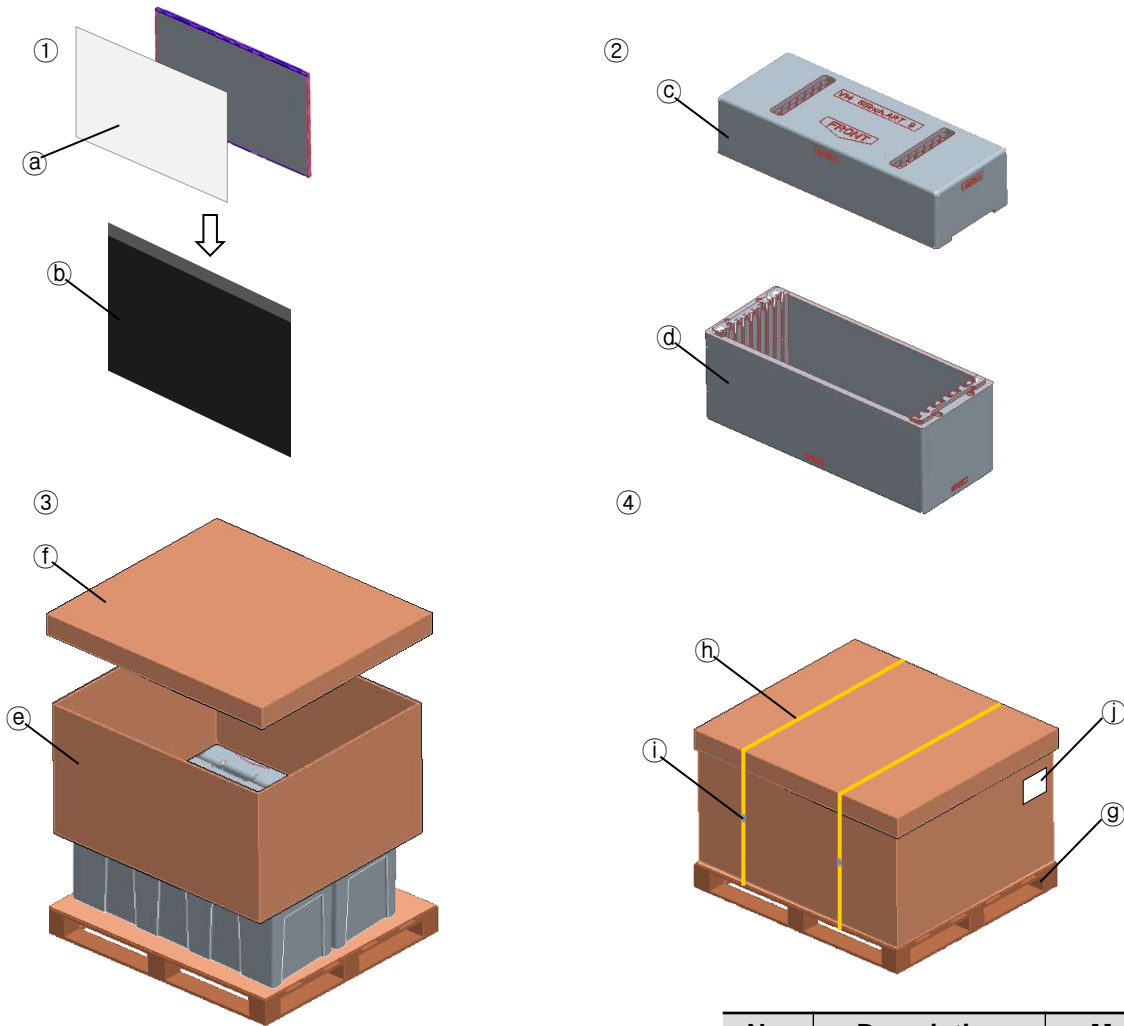

No.	Description	Material
(a)	Protect Film	PP+PE
(b)	BAG	AL
(c)	PackingTop	EPS
(d)	Packing,Bottom	EPS
(e)	Angle Packing	Double Wall
(f)	Angle Cover	Single Wall
(g)	Pallet	Plywood
(h)	Band	PP
(i)	Clip	Steel
(j)	Label	Paper

Product Specification

APPENDIX-IV

■ LCM Label

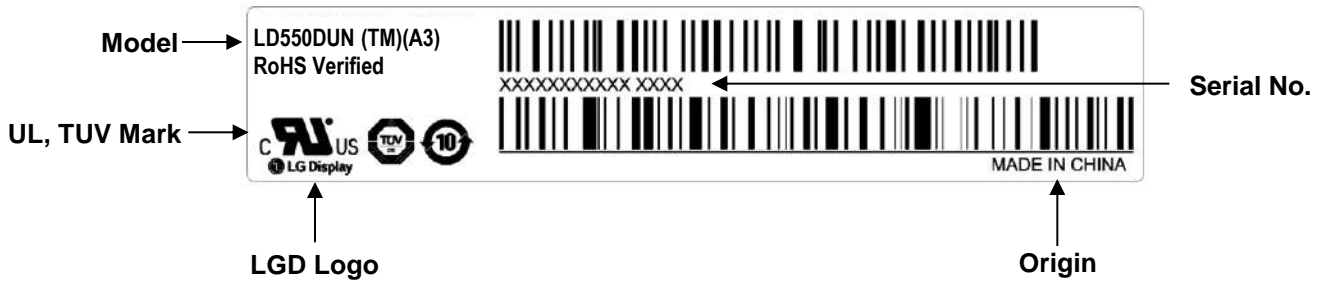

■ Production site

– LG Display (Guangzhou) Co., LTD

notes 1. The origin of LCM Label will be changed according to the production site.

Product Specification

APPENDIX- V

■ Pallet Label



APPENDIX- VI

■ Option Pin Circuit Block Diagram

1) Circuit Block Diagram of LVDS Format Selection pin

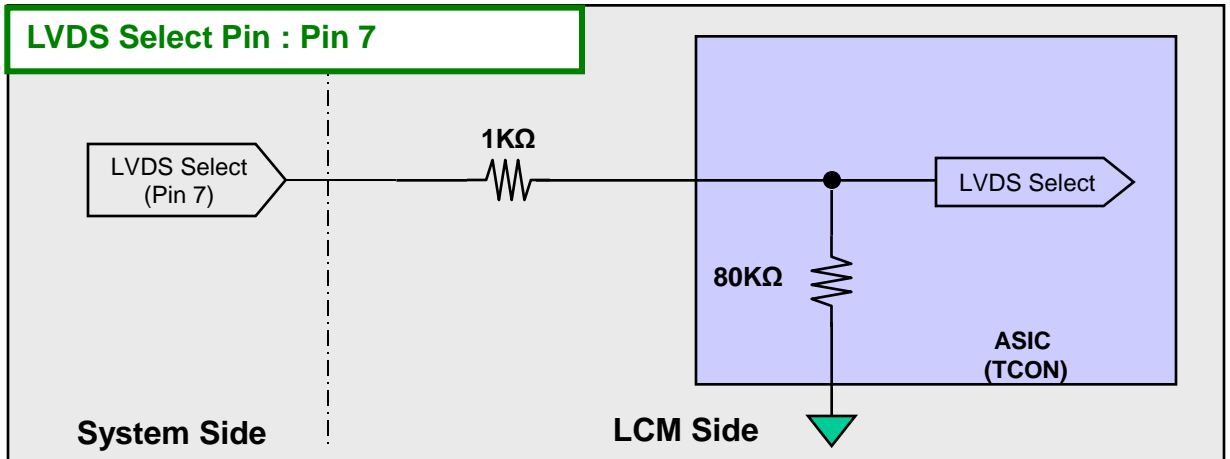

2) Circuit Block Diagram of L-DIM Enable Selection pin

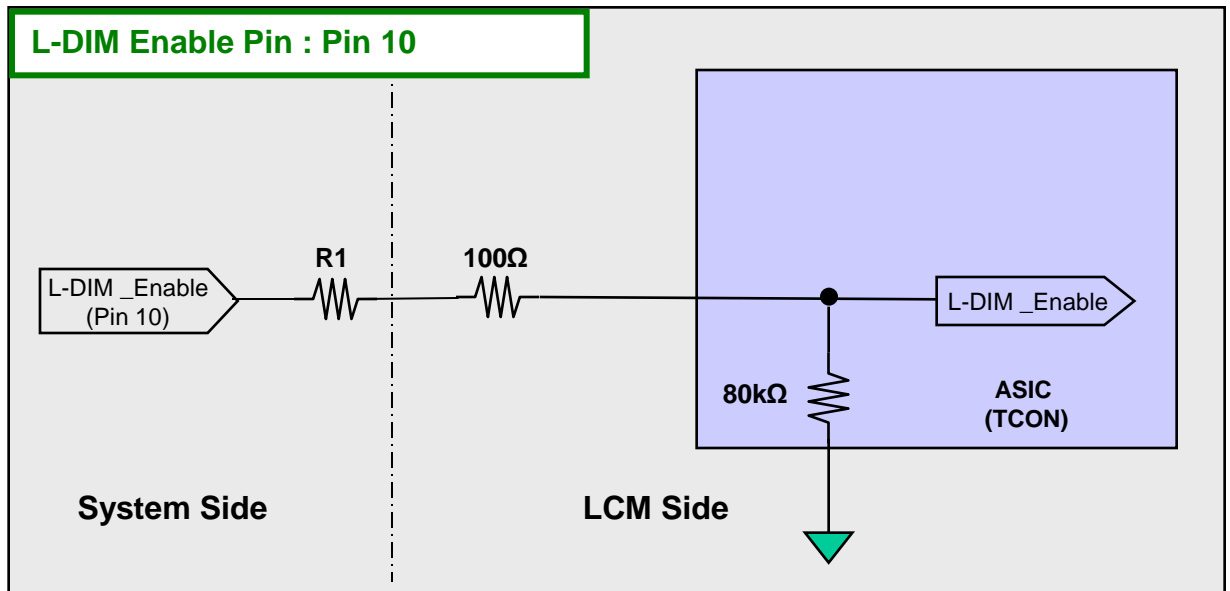

APPENDIX- VII

■ EXT_{VB}R-B & Local Dimming Design Guide

- 1) When L-Dim Enable is "L", Vertical Sync Signal = System Dimming with 100Hz or 120Hz frequency.
- 2) Local Dimming signals are synchronized with V-Sync Freq. of System in T-Con Board.
- 3) EXT_{VB}R-B Specification (VCC = 3.3V) @ Local Dimming , Reverse Specification
 - a) High Voltage Range : 2.5 V ~ 3.6 V
 - b) Low Voltage Range : 0.0 V ~ 0.7 V

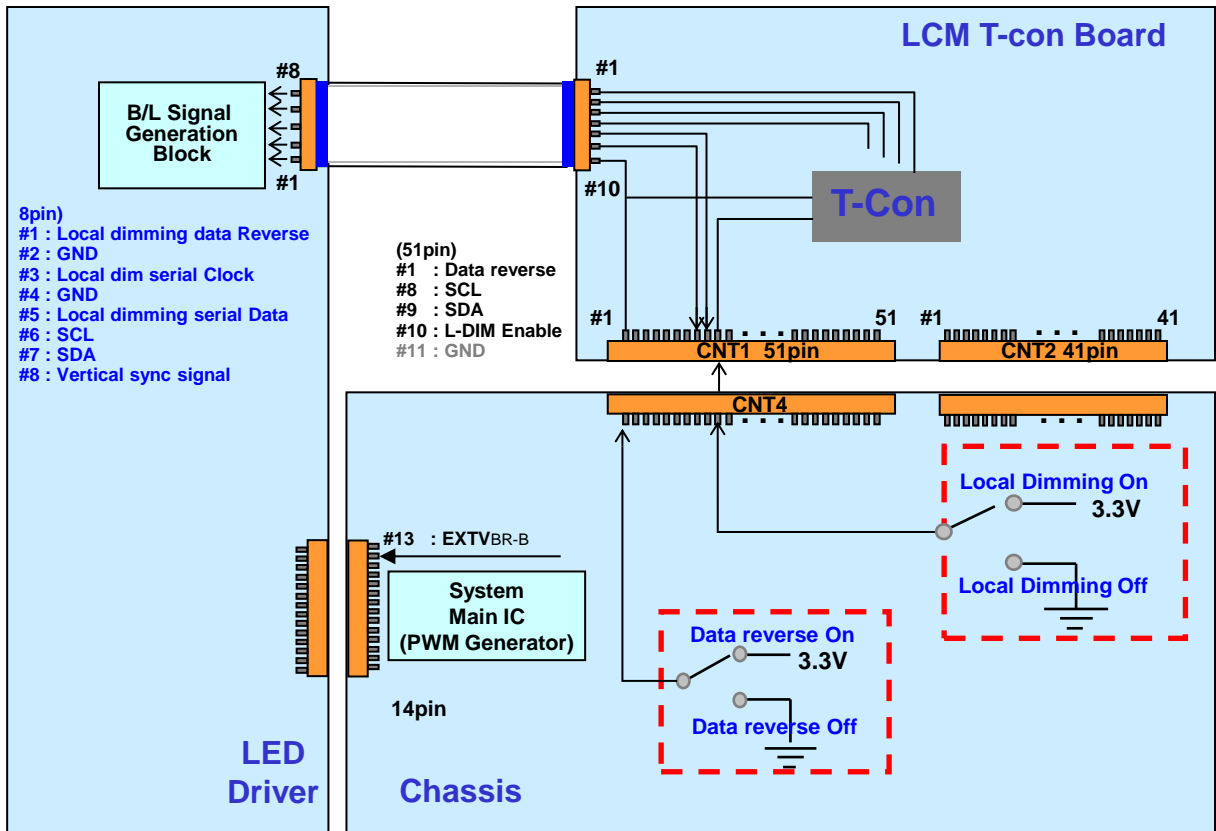

<With Driver Model>

EXT _{VB} R-B Frequency	100 Hz for PAL 120 Hz for NTSC
Rising Time	MAX 10.0 μs
Falling Time	MAX 10.0 μs

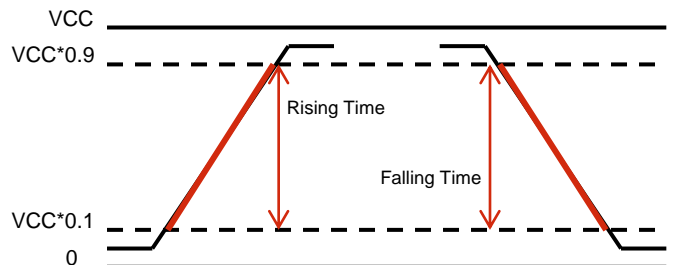

Product Specification

APPENDIX- VIII-1

Defect Detecting Mode (LED Driver)

- 1) It is possible to get defect information by I²C when LCM is defected
- 2) Failure mode that can be detected
 - Open LED, Over Voltage
 - Protection Operation status, Local Dimming Operation status

I²C Data format (2Byte)

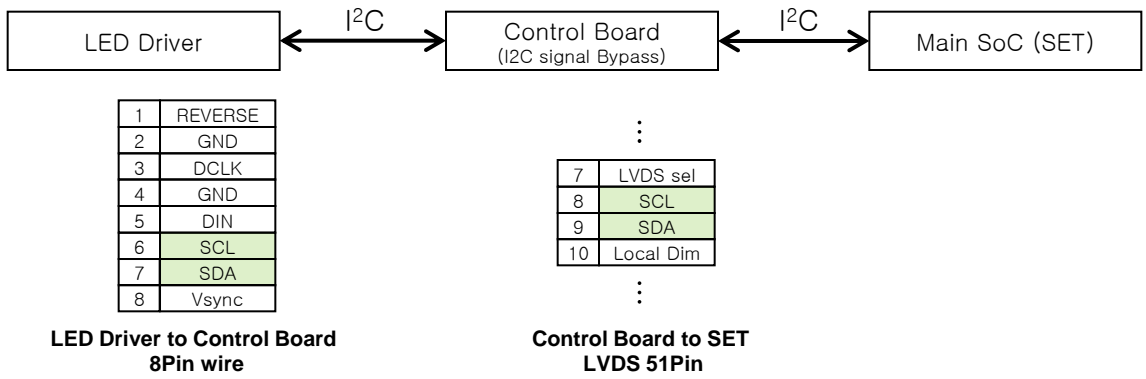
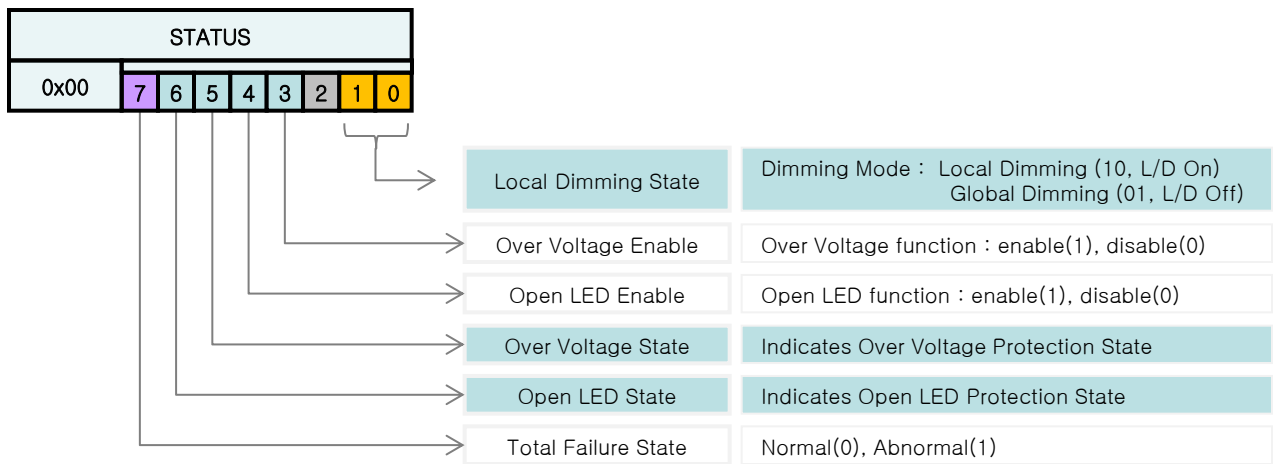

APPENDIX- VIII-2

■ SCL, SDA Pin Circuit Diagram

1) Circuit Block Diagram of LVDS SCL pin

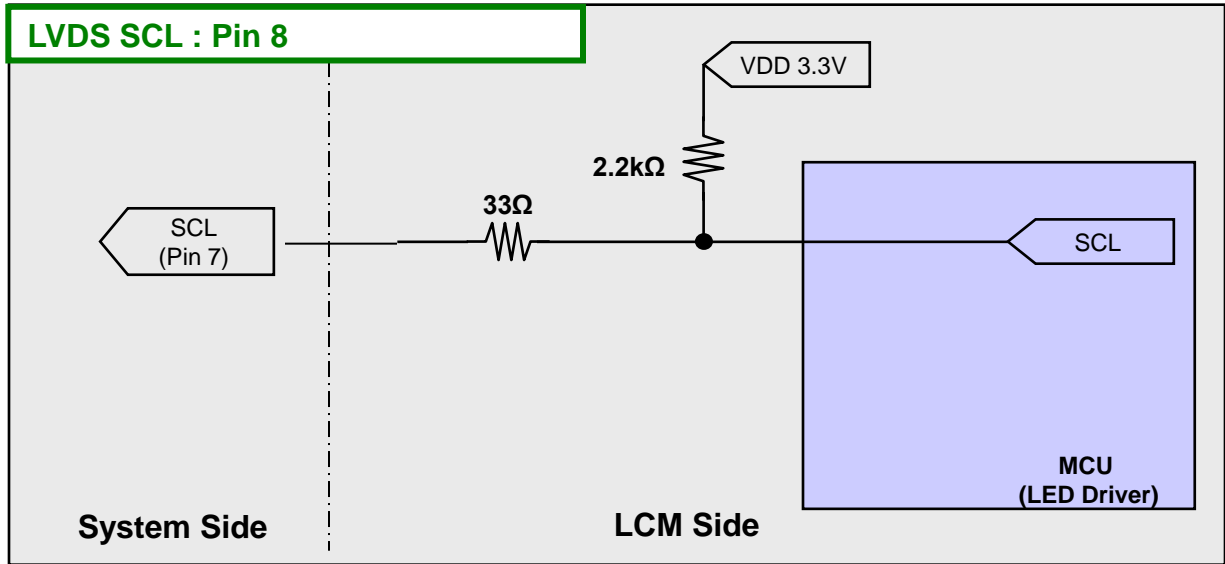

1) Circuit Block Diagram of LVDS SDA pin

