



AUO Display+

Preliminary Specification

Final Specification

<b>Module</b>	<b>6.5 Inch Color TFT-LCD</b>
<b>Model Name</b>	<b>G065VN01 V2 (97D06G01.221)</b>

<b>Company</b>	
_____	
<b>Checked &amp; Approved by</b>	<b>Date</b>
_____	_____

<b>Approved by</b>	<b>Date</b>
<u>LeaDer Feng</u>	<u>2022/12/12</u>
<b>Prepared by</b>	
<u>Danny Liao</u>	<u>2022/12/12</u>
General Display Business Unit / AUO Display Plus Corporation	

## Contents

<b>1. Operating Precautions .....</b>	<b>5</b>
<b>2. General Description.....</b>	<b>6</b>
2.1 Display Characteristics.....	6
2.2 Optical Characteristics .....	7
<b>3. Functional Block Diagram.....</b>	<b>9</b>
<b>4. Absolute Maximum Ratings .....</b>	<b>10</b>
4.1 Absolute Ratings .....	10
4.2 Absolute Ratings of Environment .....	10
<b>5. Electrical Characteristics .....</b>	<b>11</b>
5.1 TFT-LCD Driving .....	11
5.2 Backlight Unit Driving .....	13
<b>6. Signal Characteristic .....</b>	<b>13</b>
6.1 Pixel Format Image .....	13
6.2 Scanning Direction .....	14
6.3 The Input Data Format .....	15
6.4 TFT- LCD Interface Signal Description.....	16
6.5 TFT- LCD Interface Timing .....	18
6.6 LED Backlight Unit Interface Signal Description .....	19
6.7 Power ON/OFF Sequence .....	20
<b>7. Connector &amp; Pin Assignment.....</b>	<b>21</b>
7.1 TFT- LCD Signal (CN1): LCD Connector .....	21
7.2 LED Backlight Unit (CN2): Backlight Connector.....	21
7.3 PIN 1 definition of CN1 and CN2 .....	22
<b>8. Reliability Test Criteria .....</b>	<b>23</b>
<b>9. Mechanical Characteristics.....</b>	<b>24</b>
<b>10. Label and Packaging .....</b>	<b>25</b>
10.1 Shipping Label (on the rear side of TFT-LCD display) .....	25
10.2 Carton Package .....	25
<b>11 Safety .....</b>	<b>26</b>
11.1 Keen Edge Requirements .....	26
11.2 Materials .....	26
11.3 Capacitors .....	26
11.4 National Test Lab Requirement .....	26

## Record of Revision

Version and Date	Page	Old description	New Description	Remark																																																																																																																																																																																																																																												
0.1, Dec. 01, 2021	All	First edition preliminary specifications																																																																																																																																																																																																																																														
0.2 Jan. 27, 2022	6	<table border="1" style="width: 100%; border-collapse: collapse;"> <tr> <td style="width: 60%;">Typical Power Consumption</td> <td style="width: 10%;">Watt</td> <td style="width: 30%; text-align: center;">TBD</td> </tr> </table>	Typical Power Consumption	Watt	TBD	<table border="1" style="width: 100%; border-collapse: collapse;"> <tr> <td style="width: 60%;">Typical Power Consumption</td> <td style="width: 10%;">Watt</td> <td style="width: 30%; text-align: center;">2.4</td> </tr> </table>	Typical Power Consumption	Watt	2.4																																																																																																																																																																																																																																							
Typical Power Consumption	Watt	TBD																																																																																																																																																																																																																																														
Typical Power Consumption	Watt	2.4																																																																																																																																																																																																																																														
	11	<p><b>5.1.1 Power Specification</b></p> <table border="1" style="width: 100%; border-collapse: collapse;"> <thead> <tr> <th>Symbol</th> <th>Parameter</th> <th>Min</th> <th>Typ</th> <th>Max</th> <th>Units</th> <th>Remark</th> </tr> </thead> <tbody> <tr> <td>VDD</td> <td>Logic/LCD Drive Voltage</td> <td>3.0</td> <td>3.3</td> <td>3.6</td> <td>Volt</td> <td></td> </tr> <tr> <td>IDD</td> <td>VDD Current</td> <td>-</td> <td>TBD</td> <td>TBD</td> <td>mA</td> <td>All White Pattern (VDD=3.3V, at 60Hz)</td> </tr> <tr> <td>Inrush</td> <td>LCD Inrush Current</td> <td>-</td> <td>-</td> <td>1.0</td> <td>A</td> <td>Note 1</td> </tr> <tr> <td>PDD</td> <td>VDD Power</td> <td>-</td> <td>TBD</td> <td>-</td> <td>Watt</td> <td>All White Pattern (VDD=3.3V, at 60Hz)</td> </tr> </tbody> </table>	Symbol	Parameter	Min	Typ	Max	Units	Remark	VDD	Logic/LCD Drive Voltage	3.0	3.3	3.6	Volt		IDD	VDD Current	-	TBD	TBD	mA	All White Pattern (VDD=3.3V, at 60Hz)	Inrush	LCD Inrush Current	-	-	1.0	A	Note 1	PDD	VDD Power	-	TBD	-	Watt	All White Pattern (VDD=3.3V, at 60Hz)	<p><b>5.1.1 Power Specification</b></p> <table border="1" style="width: 100%; border-collapse: collapse;"> <thead> <tr> <th>Symbol</th> <th>Parameter</th> <th>Min</th> <th>Typ</th> <th>Max</th> <th>Units</th> <th>Remark</th> </tr> </thead> <tbody> <tr> <td>VDD</td> <td>Logic/LCD Drive Voltage</td> <td>3.0</td> <td>3.3</td> <td>3.6</td> <td>Volt</td> <td></td> </tr> <tr> <td>IDD</td> <td>VDD Current</td> <td>-</td> <td>0.30</td> <td>0.33</td> <td>mA</td> <td>All White Pattern (VDD=3.3V, at 60Hz)</td> </tr> <tr> <td>Inrush</td> <td>LCD Inrush Current</td> <td>-</td> <td>-</td> <td>1.0</td> <td>A</td> <td>Note 1</td> </tr> <tr> <td>PDD</td> <td>VDD Power</td> <td>-</td> <td>0.9</td> <td>-</td> <td>Watt</td> <td>All White Pattern (VDD=3.3V, at 60Hz)</td> </tr> </tbody> </table>	Symbol	Parameter	Min	Typ	Max	Units	Remark	VDD	Logic/LCD Drive Voltage	3.0	3.3	3.6	Volt		IDD	VDD Current	-	0.30	0.33	mA	All White Pattern (VDD=3.3V, at 60Hz)	Inrush	LCD Inrush Current	-	-	1.0	A	Note 1	PDD	VDD Power	-	0.9	-	Watt	All White Pattern (VDD=3.3V, at 60Hz)																																																																																																																																																																							
Symbol	Parameter	Min	Typ	Max	Units	Remark																																																																																																																																																																																																																																										
VDD	Logic/LCD Drive Voltage	3.0	3.3	3.6	Volt																																																																																																																																																																																																																																											
IDD	VDD Current	-	TBD	TBD	mA	All White Pattern (VDD=3.3V, at 60Hz)																																																																																																																																																																																																																																										
Inrush	LCD Inrush Current	-	-	1.0	A	Note 1																																																																																																																																																																																																																																										
PDD	VDD Power	-	TBD	-	Watt	All White Pattern (VDD=3.3V, at 60Hz)																																																																																																																																																																																																																																										
Symbol	Parameter	Min	Typ	Max	Units	Remark																																																																																																																																																																																																																																										
VDD	Logic/LCD Drive Voltage	3.0	3.3	3.6	Volt																																																																																																																																																																																																																																											
IDD	VDD Current	-	0.30	0.33	mA	All White Pattern (VDD=3.3V, at 60Hz)																																																																																																																																																																																																																																										
Inrush	LCD Inrush Current	-	-	1.0	A	Note 1																																																																																																																																																																																																																																										
PDD	VDD Power	-	0.9	-	Watt	All White Pattern (VDD=3.3V, at 60Hz)																																																																																																																																																																																																																																										
	13	<table border="1" style="width: 100%; border-collapse: collapse;"> <thead> <tr> <th>Symbol</th> <th>Parameter</th> <th>Min</th> <th>Typ</th> <th>Max</th> <th>Units</th> <th>Remark</th> </tr> </thead> <tbody> <tr> <td>Vin</td> <td>Input Voltage</td> <td>9</td> <td>12</td> <td>15</td> <td>Volt</td> <td></td> </tr> <tr> <td>Iin</td> <td>Input Current</td> <td>-</td> <td>TBD</td> <td>-</td> <td>A</td> <td>100% PWM duty</td> </tr> <tr> <td>Pvin</td> <td>Power Consumption</td> <td>-</td> <td>TBD</td> <td>-</td> <td>W</td> <td>100% PWM duty</td> </tr> </tbody> </table>	Symbol	Parameter	Min	Typ	Max	Units	Remark	Vin	Input Voltage	9	12	15	Volt		Iin	Input Current	-	TBD	-	A	100% PWM duty	Pvin	Power Consumption	-	TBD	-	W	100% PWM duty	<table border="1" style="width: 100%; border-collapse: collapse;"> <thead> <tr> <th>Symbol</th> <th>Parameter</th> <th>Min</th> <th>Typ</th> <th>Max</th> <th>Units</th> <th>Remark</th> </tr> </thead> <tbody> <tr> <td>Vin</td> <td>Input Voltage</td> <td>6</td> <td>12</td> <td>15</td> <td>Volt</td> <td></td> </tr> <tr> <td>Iin</td> <td>Input Current</td> <td>-</td> <td>0.767</td> <td>-</td> <td>A</td> <td>100% PWM duty</td> </tr> <tr> <td>Pvin</td> <td>Power Consumption</td> <td>-</td> <td>0.9</td> <td>-</td> <td>W</td> <td>100% PWM duty</td> </tr> </tbody> </table>	Symbol	Parameter	Min	Typ	Max	Units	Remark	Vin	Input Voltage	6	12	15	Volt		Iin	Input Current	-	0.767	-	A	100% PWM duty	Pvin	Power Consumption	-	0.9	-	W	100% PWM duty																																																																																																																																																																																					
Symbol	Parameter	Min	Typ	Max	Units	Remark																																																																																																																																																																																																																																										
Vin	Input Voltage	9	12	15	Volt																																																																																																																																																																																																																																											
Iin	Input Current	-	TBD	-	A	100% PWM duty																																																																																																																																																																																																																																										
Pvin	Power Consumption	-	TBD	-	W	100% PWM duty																																																																																																																																																																																																																																										
Symbol	Parameter	Min	Typ	Max	Units	Remark																																																																																																																																																																																																																																										
Vin	Input Voltage	6	12	15	Volt																																																																																																																																																																																																																																											
Iin	Input Current	-	0.767	-	A	100% PWM duty																																																																																																																																																																																																																																										
Pvin	Power Consumption	-	0.9	-	W	100% PWM duty																																																																																																																																																																																																																																										
	24																																																																																																																																																																																																																																															
0.3 Feb. 16, 2022	7	<p><b>2.2 Optical Characteristics</b></p> <p>The optical characteristics are measured under stable conditions at 25°C (Room Temperature).</p> <table border="1" style="width: 100%; border-collapse: collapse;"> <thead> <tr> <th>Item</th> <th>Unit</th> <th>Conditions</th> <th>Min.</th> <th>Typ.</th> <th>Max.</th> <th>Remark</th> </tr> </thead> <tbody> <tr> <td>White Luminance</td> <td>cd/m<sup>2</sup></td> <td>F<sub>max</sub> = 100% (center point)</td> <td>600</td> <td>800</td> <td>-</td> <td>Note 1</td> </tr> <tr> <td>Uniformity</td> <td>%</td> <td>5 Points</td> <td>-</td> <td>-</td> <td>1.25</td> <td>Note 1, 2, 3</td> </tr> <tr> <td>Contrast Ratio</td> <td>-</td> <td>-</td> <td>700</td> <td>1000</td> <td>-</td> <td>Note 4</td> </tr> <tr> <td rowspan="3">Response Time</td> <td>mscc</td> <td>Rising</td> <td>-</td> <td>10</td> <td>15</td> <td rowspan="3">Note 5</td> </tr> <tr> <td>mscc</td> <td>Falling</td> <td>-</td> <td>15</td> <td>20</td> </tr> <tr> <td>mscc</td> <td>Rising + Falling</td> <td>-</td> <td>25</td> <td>35</td> </tr> <tr> <td rowspan="3">Viewing Angle</td> <td>degree</td> <td>Horizontal (Right)</td> <td>80</td> <td>89</td> <td>-</td> <td rowspan="3">Note 6</td> </tr> <tr> <td>degree</td> <td>Horizontal (Left)</td> <td>80</td> <td>89</td> <td>-</td> </tr> <tr> <td>degree</td> <td>Vertical (Upper)</td> <td>80</td> <td>89</td> <td>-</td> </tr> <tr> <td rowspan="7">Color / Chromaticity Coordinates (CIE 1931)</td> <td>White x</td> <td>-</td> <td>0.263</td> <td>0.313</td> <td>0.363</td> <td></td> </tr> <tr> <td>White y</td> <td>-</td> <td>0.279</td> <td>0.329</td> <td>0.379</td> <td></td> </tr> <tr> <td>Red x</td> <td>-</td> <td>TBD</td> <td>TBD</td> <td>TBD</td> <td></td> </tr> <tr> <td>Red y</td> <td>-</td> <td>TBD</td> <td>TBD</td> <td>TBD</td> <td></td> </tr> <tr> <td>Green x</td> <td>-</td> <td>TBD</td> <td>TBD</td> <td>TBD</td> <td></td> </tr> <tr> <td>Green y</td> <td>-</td> <td>TBD</td> <td>TBD</td> <td>TBD</td> <td></td> </tr> <tr> <td>Blue x</td> <td>-</td> <td>TBD</td> <td>TBD</td> <td>TBD</td> <td></td> </tr> <tr> <td>Blue y</td> <td>-</td> <td>TBD</td> <td>TBD</td> <td>TBD</td> <td></td> </tr> <tr> <td>Color Gamut</td> <td>%</td> <td>-</td> <td>50</td> <td>55</td> <td>-</td> <td></td> </tr> </tbody> </table>	Item	Unit	Conditions	Min.	Typ.	Max.	Remark	White Luminance	cd/m <sup>2</sup>	F <sub>max</sub> = 100% (center point)	600	800	-	Note 1	Uniformity	%	5 Points	-	-	1.25	Note 1, 2, 3	Contrast Ratio	-	-	700	1000	-	Note 4	Response Time	mscc	Rising	-	10	15	Note 5	mscc	Falling	-	15	20	mscc	Rising + Falling	-	25	35	Viewing Angle	degree	Horizontal (Right)	80	89	-	Note 6	degree	Horizontal (Left)	80	89	-	degree	Vertical (Upper)	80	89	-	Color / Chromaticity Coordinates (CIE 1931)	White x	-	0.263	0.313	0.363		White y	-	0.279	0.329	0.379		Red x	-	TBD	TBD	TBD		Red y	-	TBD	TBD	TBD		Green x	-	TBD	TBD	TBD		Green y	-	TBD	TBD	TBD		Blue x	-	TBD	TBD	TBD		Blue y	-	TBD	TBD	TBD		Color Gamut	%	-	50	55	-		<p><b>2.2 Optical Characteristics</b></p> <p>The optical characteristics are measured under stable conditions at 25°C (Room Temperature).</p> <table border="1" style="width: 100%; border-collapse: collapse;"> <thead> <tr> <th>Item</th> <th>Unit</th> <th>Conditions</th> <th>Min.</th> <th>Typ.</th> <th>Max.</th> <th>Remark</th> </tr> </thead> <tbody> <tr> <td>White Luminance</td> <td>cd/m<sup>2</sup></td> <td>F<sub>max</sub> = 100% (center point)</td> <td>600</td> <td>800</td> <td>-</td> <td>Note 1</td> </tr> <tr> <td>Uniformity</td> <td>%</td> <td>5 Points</td> <td>-</td> <td>-</td> <td>1.25</td> <td>Note 1, 2, 3</td> </tr> <tr> <td>Contrast Ratio</td> <td>-</td> <td>-</td> <td>700</td> <td>1000</td> <td>-</td> <td>Note 4</td> </tr> <tr> <td rowspan="3">Response Time</td> <td>mscc</td> <td>Rising</td> <td>-</td> <td>15</td> <td>20</td> <td rowspan="3">Note 5</td> </tr> <tr> <td>mscc</td> <td>Falling</td> <td>-</td> <td>10</td> <td>15</td> </tr> <tr> <td>mscc</td> <td>Rising + Falling</td> <td>-</td> <td>25</td> <td>35</td> </tr> <tr> <td rowspan="3">Viewing Angle</td> <td>degree</td> <td>Horizontal (Right)</td> <td>80</td> <td>89</td> <td>-</td> <td rowspan="3">Note 6</td> </tr> <tr> <td>degree</td> <td>Horizontal (Left)</td> <td>80</td> <td>89</td> <td>-</td> </tr> <tr> <td>degree</td> <td>Vertical (Upper)</td> <td>80</td> <td>89</td> <td>-</td> </tr> <tr> <td rowspan="7">Color / Chromaticity Coordinates (CIE 1931)</td> <td>White x</td> <td>-</td> <td>0.263</td> <td>0.313</td> <td>0.363</td> <td></td> </tr> <tr> <td>White y</td> <td>-</td> <td>0.279</td> <td>0.329</td> <td>0.379</td> <td></td> </tr> <tr> <td>Red x</td> <td>-</td> <td>0.554</td> <td>0.604</td> <td>0.654</td> <td></td> </tr> <tr> <td>Red y</td> <td>-</td> <td>0.369</td> <td>0.391</td> <td>0.416</td> <td></td> </tr> <tr> <td>Green x</td> <td>-</td> <td>0.260</td> <td>0.306</td> <td>0.350</td> <td></td> </tr> <tr> <td>Green y</td> <td>-</td> <td>0.549</td> <td>0.586</td> <td>0.646</td> <td></td> </tr> <tr> <td>Blue x</td> <td>-</td> <td>0.181</td> <td>0.151</td> <td>0.221</td> <td></td> </tr> <tr> <td>Blue y</td> <td>-</td> <td>0.065</td> <td>0.115</td> <td>0.185</td> <td></td> </tr> <tr> <td>Color Gamut</td> <td>%</td> <td>-</td> <td>50</td> <td>55</td> <td>-</td> <td></td> </tr> </tbody> </table>	Item	Unit	Conditions	Min.	Typ.	Max.	Remark	White Luminance	cd/m <sup>2</sup>	F <sub>max</sub> = 100% (center point)	600	800	-	Note 1	Uniformity	%	5 Points	-	-	1.25	Note 1, 2, 3	Contrast Ratio	-	-	700	1000	-	Note 4	Response Time	mscc	Rising	-	15	20	Note 5	mscc	Falling	-	10	15	mscc	Rising + Falling	-	25	35	Viewing Angle	degree	Horizontal (Right)	80	89	-	Note 6	degree	Horizontal (Left)	80	89	-	degree	Vertical (Upper)	80	89	-	Color / Chromaticity Coordinates (CIE 1931)	White x	-	0.263	0.313	0.363		White y	-	0.279	0.329	0.379		Red x	-	0.554	0.604	0.654		Red y	-	0.369	0.391	0.416		Green x	-	0.260	0.306	0.350		Green y	-	0.549	0.586	0.646		Blue x	-	0.181	0.151	0.221		Blue y	-	0.065	0.115	0.185		Color Gamut	%	-	50	55	-		
Item	Unit	Conditions	Min.	Typ.	Max.	Remark																																																																																																																																																																																																																																										
White Luminance	cd/m <sup>2</sup>	F <sub>max</sub> = 100% (center point)	600	800	-	Note 1																																																																																																																																																																																																																																										
Uniformity	%	5 Points	-	-	1.25	Note 1, 2, 3																																																																																																																																																																																																																																										
Contrast Ratio	-	-	700	1000	-	Note 4																																																																																																																																																																																																																																										
Response Time	mscc	Rising	-	10	15	Note 5																																																																																																																																																																																																																																										
	mscc	Falling	-	15	20																																																																																																																																																																																																																																											
	mscc	Rising + Falling	-	25	35																																																																																																																																																																																																																																											
Viewing Angle	degree	Horizontal (Right)	80	89	-	Note 6																																																																																																																																																																																																																																										
	degree	Horizontal (Left)	80	89	-																																																																																																																																																																																																																																											
	degree	Vertical (Upper)	80	89	-																																																																																																																																																																																																																																											
Color / Chromaticity Coordinates (CIE 1931)	White x	-	0.263	0.313	0.363																																																																																																																																																																																																																																											
	White y	-	0.279	0.329	0.379																																																																																																																																																																																																																																											
	Red x	-	TBD	TBD	TBD																																																																																																																																																																																																																																											
	Red y	-	TBD	TBD	TBD																																																																																																																																																																																																																																											
	Green x	-	TBD	TBD	TBD																																																																																																																																																																																																																																											
	Green y	-	TBD	TBD	TBD																																																																																																																																																																																																																																											
	Blue x	-	TBD	TBD	TBD																																																																																																																																																																																																																																											
Blue y	-	TBD	TBD	TBD																																																																																																																																																																																																																																												
Color Gamut	%	-	50	55	-																																																																																																																																																																																																																																											
Item	Unit	Conditions	Min.	Typ.	Max.	Remark																																																																																																																																																																																																																																										
White Luminance	cd/m <sup>2</sup>	F <sub>max</sub> = 100% (center point)	600	800	-	Note 1																																																																																																																																																																																																																																										
Uniformity	%	5 Points	-	-	1.25	Note 1, 2, 3																																																																																																																																																																																																																																										
Contrast Ratio	-	-	700	1000	-	Note 4																																																																																																																																																																																																																																										
Response Time	mscc	Rising	-	15	20	Note 5																																																																																																																																																																																																																																										
	mscc	Falling	-	10	15																																																																																																																																																																																																																																											
	mscc	Rising + Falling	-	25	35																																																																																																																																																																																																																																											
Viewing Angle	degree	Horizontal (Right)	80	89	-	Note 6																																																																																																																																																																																																																																										
	degree	Horizontal (Left)	80	89	-																																																																																																																																																																																																																																											
	degree	Vertical (Upper)	80	89	-																																																																																																																																																																																																																																											
Color / Chromaticity Coordinates (CIE 1931)	White x	-	0.263	0.313	0.363																																																																																																																																																																																																																																											
	White y	-	0.279	0.329	0.379																																																																																																																																																																																																																																											
	Red x	-	0.554	0.604	0.654																																																																																																																																																																																																																																											
	Red y	-	0.369	0.391	0.416																																																																																																																																																																																																																																											
	Green x	-	0.260	0.306	0.350																																																																																																																																																																																																																																											
	Green y	-	0.549	0.586	0.646																																																																																																																																																																																																																																											
	Blue x	-	0.181	0.151	0.221																																																																																																																																																																																																																																											
Blue y	-	0.065	0.115	0.185																																																																																																																																																																																																																																												
Color Gamut	%	-	50	55	-																																																																																																																																																																																																																																											
	23	<p><b>8. Reliability Test Criteria</b></p> <table border="1" style="width: 100%; border-collapse: collapse;"> <thead> <tr> <th>Items</th> <th>Required Condition</th> <th>Remark</th> </tr> </thead> <tbody> <tr> <td>Temperature Humidity Bias</td> <td>40°C/90%, 300hr</td> <td>Note 2</td> </tr> <tr> <td>High Temperature Operation</td> <td>60°C, 200hr</td> <td>Note 2</td> </tr> <tr> <td>Low Temperature Operation</td> <td>-30°C, 300hr</td> <td>Note 2</td> </tr> <tr> <td>High Temperature Storage</td> <td>60°C, 300 hours</td> <td>Note 2</td> </tr> <tr> <td>Low Temperature Storage</td> <td>-30°C, 300 hours</td> <td>Note 2</td> </tr> <tr> <td>Thermal Shock Test</td> <td>-30°C/30 min, 60°C/30 min, 100cycles</td> <td>Note 2</td> </tr> <tr> <td>Hot Start Test</td> <td>60°C/1 Hr (min.), power on/off per 5 minutes, repeat 5 times</td> <td>Note 2</td> </tr> <tr> <td>Cold Start Test</td> <td>-30°C/1 Hr (min.), power on/off per 5 minutes, repeat 5 times</td> <td>Note 2</td> </tr> <tr> <td>Shock Test (Non-Operating)</td> <td>50G, 20ms, Half-sine wave, (x, y, z)</td> <td>Note 2</td> </tr> <tr> <td>Vibration Test (Non-Operating)</td> <td>1.5G, 10-200-10Hz, Sine wave, 30mins/axis, 3 direction (X, Y, Z)</td> <td>Note 2</td> </tr> <tr> <td>ESD</td> <td>Contact Discharge: ±8KV, 150pF(3300) 1sec, 8 points, 25 times/point Air Discharge: ±15KV, 150pF(3300) 1sec, 8 points, 25 times/point</td> <td>Note 1,2</td> </tr> </tbody> </table>	Items	Required Condition	Remark	Temperature Humidity Bias	40°C/90%, 300hr	Note 2	High Temperature Operation	60°C, 200hr	Note 2	Low Temperature Operation	-30°C, 300hr	Note 2	High Temperature Storage	60°C, 300 hours	Note 2	Low Temperature Storage	-30°C, 300 hours	Note 2	Thermal Shock Test	-30°C/30 min, 60°C/30 min, 100cycles	Note 2	Hot Start Test	60°C/1 Hr (min.), power on/off per 5 minutes, repeat 5 times	Note 2	Cold Start Test	-30°C/1 Hr (min.), power on/off per 5 minutes, repeat 5 times	Note 2	Shock Test (Non-Operating)	50G, 20ms, Half-sine wave, (x, y, z)	Note 2	Vibration Test (Non-Operating)	1.5G, 10-200-10Hz, Sine wave, 30mins/axis, 3 direction (X, Y, Z)	Note 2	ESD	Contact Discharge: ±8KV, 150pF(3300) 1sec, 8 points, 25 times/point Air Discharge: ±15KV, 150pF(3300) 1sec, 8 points, 25 times/point	Note 1,2	<p><b>8. Reliability Test Criteria</b></p> <table border="1" style="width: 100%; border-collapse: collapse;"> <thead> <tr> <th>Items</th> <th>Required Condition</th> <th>Remark</th> </tr> </thead> <tbody> <tr> <td>Temperature Humidity Bias</td> <td>60°C/90%, 300hr</td> <td>Note 2</td> </tr> <tr> <td>High Temperature Operation</td> <td>60°C, 300hr</td> <td>Note 2</td> </tr> <tr> <td>Low Temperature Operation</td> <td>-30°C, 300hr</td> <td>Note 2</td> </tr> <tr> <td>High Temperature Storage</td> <td>60°C, 300 hours</td> <td>Note 2</td> </tr> <tr> <td>Low Temperature Storage</td> <td>-30°C, 300 hours</td> <td>Note 2</td> </tr> <tr> <td>Thermal Shock Test</td> <td>-30°C/30 min, 60°C/30 min, 100cycles</td> <td>Note 2</td> </tr> <tr> <td>Hot Start Test</td> <td>60°C/1 Hr (min.), power on/off per 5 minutes, repeat 5 times</td> <td>Note 2</td> </tr> <tr> <td>Cold Start Test</td> <td>-30°C/1 Hr (min.), power on/off per 5 minutes, repeat 5 times</td> <td>Note 2</td> </tr> <tr> <td>Shock Test (Non-Operating)</td> <td>50G, 20ms, Half-sine wave, (x, y, z)</td> <td>Note 2</td> </tr> <tr> <td>Vibration Test (Non-Operating)</td> <td>1.5G, 10-200-10Hz, Sine wave, 30mins/axis, 3 direction (X, Y, Z)</td> <td>Note 2</td> </tr> <tr> <td>ESD</td> <td>Contact Discharge: ±8KV, 150pF(3300) 1sec, 8 points, 25 times/point Air Discharge: ±15KV, 150pF(3300) 1sec, 8 points, 25 times/point</td> <td>Note 1,2</td> </tr> <tr> <td>Altitude Test</td> <td>Operating: 14,000 ft, Ramp: 2000 ft/min, 8hrs Non-operating: 40,000 ft, Ramp: 2000 ft/min, 24hrs</td> <td>Note 2</td> </tr> </tbody> </table>	Items	Required Condition	Remark	Temperature Humidity Bias	60°C/90%, 300hr	Note 2	High Temperature Operation	60°C, 300hr	Note 2	Low Temperature Operation	-30°C, 300hr	Note 2	High Temperature Storage	60°C, 300 hours	Note 2	Low Temperature Storage	-30°C, 300 hours	Note 2	Thermal Shock Test	-30°C/30 min, 60°C/30 min, 100cycles	Note 2	Hot Start Test	60°C/1 Hr (min.), power on/off per 5 minutes, repeat 5 times	Note 2	Cold Start Test	-30°C/1 Hr (min.), power on/off per 5 minutes, repeat 5 times	Note 2	Shock Test (Non-Operating)	50G, 20ms, Half-sine wave, (x, y, z)	Note 2	Vibration Test (Non-Operating)	1.5G, 10-200-10Hz, Sine wave, 30mins/axis, 3 direction (X, Y, Z)	Note 2	ESD	Contact Discharge: ±8KV, 150pF(3300) 1sec, 8 points, 25 times/point Air Discharge: ±15KV, 150pF(3300) 1sec, 8 points, 25 times/point	Note 1,2	Altitude Test	Operating: 14,000 ft, Ramp: 2000 ft/min, 8hrs Non-operating: 40,000 ft, Ramp: 2000 ft/min, 24hrs	Note 2																																																																																																																																																																		
Items	Required Condition	Remark																																																																																																																																																																																																																																														
Temperature Humidity Bias	40°C/90%, 300hr	Note 2																																																																																																																																																																																																																																														
High Temperature Operation	60°C, 200hr	Note 2																																																																																																																																																																																																																																														
Low Temperature Operation	-30°C, 300hr	Note 2																																																																																																																																																																																																																																														
High Temperature Storage	60°C, 300 hours	Note 2																																																																																																																																																																																																																																														
Low Temperature Storage	-30°C, 300 hours	Note 2																																																																																																																																																																																																																																														
Thermal Shock Test	-30°C/30 min, 60°C/30 min, 100cycles	Note 2																																																																																																																																																																																																																																														
Hot Start Test	60°C/1 Hr (min.), power on/off per 5 minutes, repeat 5 times	Note 2																																																																																																																																																																																																																																														
Cold Start Test	-30°C/1 Hr (min.), power on/off per 5 minutes, repeat 5 times	Note 2																																																																																																																																																																																																																																														
Shock Test (Non-Operating)	50G, 20ms, Half-sine wave, (x, y, z)	Note 2																																																																																																																																																																																																																																														
Vibration Test (Non-Operating)	1.5G, 10-200-10Hz, Sine wave, 30mins/axis, 3 direction (X, Y, Z)	Note 2																																																																																																																																																																																																																																														
ESD	Contact Discharge: ±8KV, 150pF(3300) 1sec, 8 points, 25 times/point Air Discharge: ±15KV, 150pF(3300) 1sec, 8 points, 25 times/point	Note 1,2																																																																																																																																																																																																																																														
Items	Required Condition	Remark																																																																																																																																																																																																																																														
Temperature Humidity Bias	60°C/90%, 300hr	Note 2																																																																																																																																																																																																																																														
High Temperature Operation	60°C, 300hr	Note 2																																																																																																																																																																																																																																														
Low Temperature Operation	-30°C, 300hr	Note 2																																																																																																																																																																																																																																														
High Temperature Storage	60°C, 300 hours	Note 2																																																																																																																																																																																																																																														
Low Temperature Storage	-30°C, 300 hours	Note 2																																																																																																																																																																																																																																														
Thermal Shock Test	-30°C/30 min, 60°C/30 min, 100cycles	Note 2																																																																																																																																																																																																																																														
Hot Start Test	60°C/1 Hr (min.), power on/off per 5 minutes, repeat 5 times	Note 2																																																																																																																																																																																																																																														
Cold Start Test	-30°C/1 Hr (min.), power on/off per 5 minutes, repeat 5 times	Note 2																																																																																																																																																																																																																																														
Shock Test (Non-Operating)	50G, 20ms, Half-sine wave, (x, y, z)	Note 2																																																																																																																																																																																																																																														
Vibration Test (Non-Operating)	1.5G, 10-200-10Hz, Sine wave, 30mins/axis, 3 direction (X, Y, Z)	Note 2																																																																																																																																																																																																																																														
ESD	Contact Discharge: ±8KV, 150pF(3300) 1sec, 8 points, 25 times/point Air Discharge: ±15KV, 150pF(3300) 1sec, 8 points, 25 times/point	Note 1,2																																																																																																																																																																																																																																														
Altitude Test	Operating: 14,000 ft, Ramp: 2000 ft/min, 8hrs Non-operating: 40,000 ft, Ramp: 2000 ft/min, 24hrs	Note 2																																																																																																																																																																																																																																														
0.4 Mar. 08, 2022	24																																																																																																																																																																																																																																															

Version and Date	Page	Old description	New Description	Remark																																																																																				
0.5, Jul. 08, 2022	6	<table border="1"> <tr> <td>Typical Power Consumption:</td> <td>Watt:</td> <td>(2.4)</td> </tr> <tr> <td>Weight:</td> <td>Grams:</td> <td>TBD</td> </tr> </table>	Typical Power Consumption:	Watt:	(2.4)	Weight:	Grams:	TBD	<table border="1"> <tr> <td>Typical Power Consumption:</td> <td>Watt:</td> <td>2.27</td> </tr> <tr> <td>Weight:</td> <td>Grams:</td> <td>170 (typ)</td> </tr> </table>	Typical Power Consumption:	Watt:	2.27	Weight:	Grams:	170 (typ)																																																																									
Typical Power Consumption:	Watt:	(2.4)																																																																																						
Weight:	Grams:	TBD																																																																																						
Typical Power Consumption:	Watt:	2.27																																																																																						
Weight:	Grams:	170 (typ)																																																																																						
	7	<table border="1"> <tr> <td rowspan="7">Color / Chromaticity Coordinates (CIE 1931)</td> <td>White x</td> <td>0.263</td> <td>0.313</td> <td>0.363</td> </tr> <tr> <td>White y</td> <td>0.279</td> <td>0.329</td> <td>0.379</td> </tr> <tr> <td>Red x</td> <td>(0.554)</td> <td>(0.604)</td> <td>(0.654)</td> </tr> <tr> <td>Red y</td> <td>(0.308)</td> <td>(0.358)</td> <td>(0.408)</td> </tr> <tr> <td>Green x</td> <td>(0.280)</td> <td>(0.330)</td> <td>(0.380)</td> </tr> <tr> <td>Green y</td> <td>(0.549)</td> <td>(0.599)</td> <td>(0.649)</td> </tr> <tr> <td>Blue x</td> <td>(0.101)</td> <td>(0.151)</td> <td>(0.201)</td> </tr> <tr> <td>Blue y</td> <td>(0.065)</td> <td>(0.115)</td> <td>(0.165)</td> </tr> <tr> <td>Color Gamut</td> <td>%</td> <td>50</td> <td>55</td> <td>60</td> </tr> </table>	Color / Chromaticity Coordinates (CIE 1931)	White x	0.263	0.313	0.363	White y	0.279	0.329	0.379	Red x	(0.554)	(0.604)	(0.654)	Red y	(0.308)	(0.358)	(0.408)	Green x	(0.280)	(0.330)	(0.380)	Green y	(0.549)	(0.599)	(0.649)	Blue x	(0.101)	(0.151)	(0.201)	Blue y	(0.065)	(0.115)	(0.165)	Color Gamut	%	50	55	60	<table border="1"> <tr> <td rowspan="7">Color / Chromaticity Coordinates (CIE 1931)</td> <td>White x</td> <td>0.263</td> <td>0.313</td> <td>0.363</td> </tr> <tr> <td>White y</td> <td>0.279</td> <td>0.329</td> <td>0.379</td> </tr> <tr> <td>Red x</td> <td>(0.554)</td> <td>(0.604)</td> <td>(0.654)</td> </tr> <tr> <td>Red y</td> <td>(0.301)</td> <td>(0.351)</td> <td>(0.401)</td> </tr> <tr> <td>Green x</td> <td>(0.277)</td> <td>(0.327)</td> <td>(0.377)</td> </tr> <tr> <td>Green y</td> <td>(0.551)</td> <td>(0.601)</td> <td>(0.651)</td> </tr> <tr> <td>Blue x</td> <td>(0.103)</td> <td>(0.153)</td> <td>(0.203)</td> </tr> <tr> <td>Blue y</td> <td>(0.063)</td> <td>(0.113)</td> <td>(0.163)</td> </tr> <tr> <td>Color Gamut</td> <td>%</td> <td>50</td> <td>55</td> <td>60</td> </tr> </table>	Color / Chromaticity Coordinates (CIE 1931)	White x	0.263	0.313	0.363	White y	0.279	0.329	0.379	Red x	(0.554)	(0.604)	(0.654)	Red y	(0.301)	(0.351)	(0.401)	Green x	(0.277)	(0.327)	(0.377)	Green y	(0.551)	(0.601)	(0.651)	Blue x	(0.103)	(0.153)	(0.203)	Blue y	(0.063)	(0.113)	(0.163)	Color Gamut	%	50	55	60									
Color / Chromaticity Coordinates (CIE 1931)	White x	0.263		0.313	0.363																																																																																			
	White y	0.279		0.329	0.379																																																																																			
	Red x	(0.554)		(0.604)	(0.654)																																																																																			
	Red y	(0.308)		(0.358)	(0.408)																																																																																			
	Green x	(0.280)		(0.330)	(0.380)																																																																																			
	Green y	(0.549)		(0.599)	(0.649)																																																																																			
	Blue x	(0.101)	(0.151)	(0.201)																																																																																				
Blue y	(0.065)	(0.115)	(0.165)																																																																																					
Color Gamut	%	50	55	60																																																																																				
Color / Chromaticity Coordinates (CIE 1931)	White x	0.263	0.313	0.363																																																																																				
	White y	0.279	0.329	0.379																																																																																				
	Red x	(0.554)	(0.604)	(0.654)																																																																																				
	Red y	(0.301)	(0.351)	(0.401)																																																																																				
	Green x	(0.277)	(0.327)	(0.377)																																																																																				
	Green y	(0.551)	(0.601)	(0.651)																																																																																				
	Blue x	(0.103)	(0.153)	(0.203)																																																																																				
Blue y	(0.063)	(0.113)	(0.163)																																																																																					
Color Gamut	%	50	55	60																																																																																				
	10	<p><b>4.1 Absolute Ratings</b></p> <table border="1"> <thead> <tr> <th>Items</th> <th>Symbol</th> <th>Min</th> <th>Max</th> <th>Unit</th> <th>Remark</th> </tr> </thead> <tbody> <tr> <td>LogicLCD Drive Voltage</td> <td>VDD</td> <td>-0.3</td> <td>+4.0</td> <td>Volt</td> <td>Ta= 25°C</td> </tr> <tr> <td>LCD Input Signal Voltage</td> <td>VIN</td> <td>-0.3</td> <td>+4.0</td> <td>Volt</td> <td>Ta= 25°C</td> </tr> <tr> <td>LED BLU Drive Voltage</td> <td>VLED</td> <td>0</td> <td>16</td> <td>Volt</td> <td>Ta= 25°C</td> </tr> <tr> <td>LED Dimming Input Voltage</td> <td>VDim</td> <td>0</td> <td>6</td> <td>Volt</td> <td>Ta= 25°C</td> </tr> </tbody> </table>	Items	Symbol	Min	Max	Unit	Remark	LogicLCD Drive Voltage	VDD	-0.3	+4.0	Volt	Ta= 25°C	LCD Input Signal Voltage	VIN	-0.3	+4.0	Volt	Ta= 25°C	LED BLU Drive Voltage	VLED	0	16	Volt	Ta= 25°C	LED Dimming Input Voltage	VDim	0	6	Volt	Ta= 25°C	<p><b>4.1 Absolute Ratings</b></p> <table border="1"> <thead> <tr> <th>Items</th> <th>Symbol</th> <th>Min</th> <th>Max</th> <th>Unit</th> <th>Remark</th> </tr> </thead> <tbody> <tr> <td>LogicLCD Drive Voltage</td> <td>VDD</td> <td>-0.3</td> <td>+3.6</td> <td>Volt</td> <td>Ta= 25°C</td> </tr> <tr> <td>LCD Input Signal Voltage</td> <td>VIN</td> <td>-0.3</td> <td>+3.6</td> <td>Volt</td> <td>Ta= 25°C</td> </tr> <tr> <td>LED BLU Drive Voltage</td> <td>VLED</td> <td>0</td> <td>16</td> <td>Volt</td> <td>Ta= 25°C</td> </tr> <tr> <td>LED Dimming Input Voltage</td> <td>VDim</td> <td>0</td> <td>6</td> <td>Volt</td> <td>Ta= 25°C</td> </tr> </tbody> </table>	Items	Symbol	Min	Max	Unit	Remark	LogicLCD Drive Voltage	VDD	-0.3	+3.6	Volt	Ta= 25°C	LCD Input Signal Voltage	VIN	-0.3	+3.6	Volt	Ta= 25°C	LED BLU Drive Voltage	VLED	0	16	Volt	Ta= 25°C	LED Dimming Input Voltage	VDim	0	6	Volt	Ta= 25°C																									
Items	Symbol	Min	Max	Unit	Remark																																																																																			
LogicLCD Drive Voltage	VDD	-0.3	+4.0	Volt	Ta= 25°C																																																																																			
LCD Input Signal Voltage	VIN	-0.3	+4.0	Volt	Ta= 25°C																																																																																			
LED BLU Drive Voltage	VLED	0	16	Volt	Ta= 25°C																																																																																			
LED Dimming Input Voltage	VDim	0	6	Volt	Ta= 25°C																																																																																			
Items	Symbol	Min	Max	Unit	Remark																																																																																			
LogicLCD Drive Voltage	VDD	-0.3	+3.6	Volt	Ta= 25°C																																																																																			
LCD Input Signal Voltage	VIN	-0.3	+3.6	Volt	Ta= 25°C																																																																																			
LED BLU Drive Voltage	VLED	0	16	Volt	Ta= 25°C																																																																																			
LED Dimming Input Voltage	VDim	0	6	Volt	Ta= 25°C																																																																																			
	11	<p><b>5.1.1 Power Specification</b></p> <table border="1"> <thead> <tr> <th>Symbol</th> <th>Parameter</th> <th>Min</th> <th>Typ</th> <th>Max</th> <th>Units</th> <th>Remark</th> </tr> </thead> <tbody> <tr> <td>VDD</td> <td>LogicLCD Drive Voltage</td> <td>3.0</td> <td>3.3</td> <td>3.6</td> <td>Volt</td> <td>-</td> </tr> <tr> <td>IDD</td> <td>VDD Current</td> <td>-</td> <td>(120)</td> <td>(133)</td> <td>mA</td> <td>All White Pattern (VDD=3.3V, at 60Hz)</td> </tr> <tr> <td>Inrush</td> <td>LCD Inrush Current</td> <td>-</td> <td>-</td> <td>1.0</td> <td>A</td> <td>Note 1</td> </tr> <tr> <td>PDD</td> <td>VDD Power</td> <td>-</td> <td>(0.4)</td> <td>-</td> <td>Watt</td> <td>All White Pattern (VDD=3.3V, at 60Hz)</td> </tr> <tr> <td>VDDrip</td> <td>Allowable LogicLCD Drive Ripple Voltage</td> <td>-</td> <td>-</td> <td>100</td> <td>mVp-p</td> <td>All White Pattern (VDD=3.3V, at 60Hz)</td> </tr> </tbody> </table>	Symbol	Parameter	Min	Typ	Max	Units	Remark	VDD	LogicLCD Drive Voltage	3.0	3.3	3.6	Volt	-	IDD	VDD Current	-	(120)	(133)	mA	All White Pattern (VDD=3.3V, at 60Hz)	Inrush	LCD Inrush Current	-	-	1.0	A	Note 1	PDD	VDD Power	-	(0.4)	-	Watt	All White Pattern (VDD=3.3V, at 60Hz)	VDDrip	Allowable LogicLCD Drive Ripple Voltage	-	-	100	mVp-p	All White Pattern (VDD=3.3V, at 60Hz)	<p><b>5.1.1 Power Specification</b></p> <table border="1"> <thead> <tr> <th>Symbol</th> <th>Parameter</th> <th>Min</th> <th>Typ</th> <th>Max</th> <th>Units</th> <th>Remark</th> </tr> </thead> <tbody> <tr> <td>VDD</td> <td>LogicLCD Drive Voltage</td> <td>3.0</td> <td>3.3</td> <td>3.5</td> <td>Volt</td> <td>-</td> </tr> <tr> <td>IDD</td> <td>VDD Current</td> <td>-</td> <td>12</td> <td>100</td> <td>mA</td> <td>All White Pattern (VDD=3.3V, at 60Hz)</td> </tr> <tr> <td>Inrush</td> <td>LCD Inrush Current</td> <td>-</td> <td>-</td> <td>1.0</td> <td>A</td> <td>Note 1</td> </tr> <tr> <td>PDD</td> <td>VDD Power</td> <td>-</td> <td>0.27</td> <td>-</td> <td>Watt</td> <td>All White Pattern (VDD=3.3V, at 60Hz)</td> </tr> <tr> <td>VDDrip</td> <td>Allowable LogicLCD Drive Ripple Voltage</td> <td>-</td> <td>-</td> <td>100</td> <td>mVp-p</td> <td>All White Pattern (VDD=3.3V, at 60Hz)</td> </tr> </tbody> </table>	Symbol	Parameter	Min	Typ	Max	Units	Remark	VDD	LogicLCD Drive Voltage	3.0	3.3	3.5	Volt	-	IDD	VDD Current	-	12	100	mA	All White Pattern (VDD=3.3V, at 60Hz)	Inrush	LCD Inrush Current	-	-	1.0	A	Note 1	PDD	VDD Power	-	0.27	-	Watt	All White Pattern (VDD=3.3V, at 60Hz)	VDDrip	Allowable LogicLCD Drive Ripple Voltage	-	-	100	mVp-p	All White Pattern (VDD=3.3V, at 60Hz)	
Symbol	Parameter	Min	Typ	Max	Units	Remark																																																																																		
VDD	LogicLCD Drive Voltage	3.0	3.3	3.6	Volt	-																																																																																		
IDD	VDD Current	-	(120)	(133)	mA	All White Pattern (VDD=3.3V, at 60Hz)																																																																																		
Inrush	LCD Inrush Current	-	-	1.0	A	Note 1																																																																																		
PDD	VDD Power	-	(0.4)	-	Watt	All White Pattern (VDD=3.3V, at 60Hz)																																																																																		
VDDrip	Allowable LogicLCD Drive Ripple Voltage	-	-	100	mVp-p	All White Pattern (VDD=3.3V, at 60Hz)																																																																																		
Symbol	Parameter	Min	Typ	Max	Units	Remark																																																																																		
VDD	LogicLCD Drive Voltage	3.0	3.3	3.5	Volt	-																																																																																		
IDD	VDD Current	-	12	100	mA	All White Pattern (VDD=3.3V, at 60Hz)																																																																																		
Inrush	LCD Inrush Current	-	-	1.0	A	Note 1																																																																																		
PDD	VDD Power	-	0.27	-	Watt	All White Pattern (VDD=3.3V, at 60Hz)																																																																																		
VDDrip	Allowable LogicLCD Drive Ripple Voltage	-	-	100	mVp-p	All White Pattern (VDD=3.3V, at 60Hz)																																																																																		
	13	<p><b>5.2.1 Parameter guideline for LED driver</b> Following characteristics are measured under static condition at 25°C (Room Temperature)</p> <table border="1"> <thead> <tr> <th>Symbol</th> <th>Parameter</th> <th>Min</th> <th>Typ</th> <th>Max</th> <th>Units</th> <th>Remark</th> </tr> </thead> <tbody> <tr> <td>V<sub>LED</sub></td> <td>Input Voltage</td> <td>9</td> <td>12</td> <td>13</td> <td>Volt</td> <td>-</td> </tr> <tr> <td>I<sub>LED</sub></td> <td>Input Current</td> <td>-</td> <td>(0.167)</td> <td>-</td> <td>A</td> <td>100% PWM duty</td> </tr> <tr> <td>P<sub>LED</sub></td> <td>Power Consumption</td> <td>-</td> <td>(2)</td> <td>-</td> <td>W</td> <td>100% PWM duty</td> </tr> <tr> <td>Inrush<sub>LED</sub></td> <td>Inrush Current</td> <td>-</td> <td>TBD</td> <td>TBD</td> <td>A</td> <td>100% PWM duty</td> </tr> </tbody> </table>	Symbol	Parameter	Min	Typ	Max	Units	Remark	V <sub>LED</sub>	Input Voltage	9	12	13	Volt	-	I <sub>LED</sub>	Input Current	-	(0.167)	-	A	100% PWM duty	P <sub>LED</sub>	Power Consumption	-	(2)	-	W	100% PWM duty	Inrush <sub>LED</sub>	Inrush Current	-	TBD	TBD	A	100% PWM duty	<p><b>5.2.1 Parameter guideline for LED driver</b> Following characteristics are measured under static condition at 25°C (Room Temperature)</p> <table border="1"> <thead> <tr> <th>Symbol</th> <th>Parameter</th> <th>Min</th> <th>Typ</th> <th>Max</th> <th>Units</th> <th>Remark</th> </tr> </thead> <tbody> <tr> <td>V<sub>LED</sub></td> <td>Input Voltage</td> <td>9</td> <td>12</td> <td>13</td> <td>Volt</td> <td>-</td> </tr> <tr> <td>I<sub>LED</sub></td> <td>Input Current</td> <td>-</td> <td>0.167</td> <td>-</td> <td>A</td> <td>100% PWM duty</td> </tr> <tr> <td>P<sub>LED</sub></td> <td>Power Consumption</td> <td>-</td> <td>2</td> <td>-</td> <td>W</td> <td>100% PWM duty</td> </tr> <tr> <td>Inrush<sub>LED</sub></td> <td>Inrush Current</td> <td>-</td> <td>0.22</td> <td>0.47</td> <td>A</td> <td>100% PWM duty</td> </tr> </tbody> </table>	Symbol	Parameter	Min	Typ	Max	Units	Remark	V <sub>LED</sub>	Input Voltage	9	12	13	Volt	-	I <sub>LED</sub>	Input Current	-	0.167	-	A	100% PWM duty	P <sub>LED</sub>	Power Consumption	-	2	-	W	100% PWM duty	Inrush <sub>LED</sub>	Inrush Current	-	0.22	0.47	A	100% PWM duty															
Symbol	Parameter	Min	Typ	Max	Units	Remark																																																																																		
V <sub>LED</sub>	Input Voltage	9	12	13	Volt	-																																																																																		
I <sub>LED</sub>	Input Current	-	(0.167)	-	A	100% PWM duty																																																																																		
P <sub>LED</sub>	Power Consumption	-	(2)	-	W	100% PWM duty																																																																																		
Inrush <sub>LED</sub>	Inrush Current	-	TBD	TBD	A	100% PWM duty																																																																																		
Symbol	Parameter	Min	Typ	Max	Units	Remark																																																																																		
V <sub>LED</sub>	Input Voltage	9	12	13	Volt	-																																																																																		
I <sub>LED</sub>	Input Current	-	0.167	-	A	100% PWM duty																																																																																		
P <sub>LED</sub>	Power Consumption	-	2	-	W	100% PWM duty																																																																																		
Inrush <sub>LED</sub>	Inrush Current	-	0.22	0.47	A	100% PWM duty																																																																																		
	22																																																																																							
	24																																																																																							
1.0, Dec. 12, 2022	25	<p><b>10.2 Carton Package:</b> Max. capacity: 80 TFT-LCD module per carton (40pcs * 2 layers) Max. weight: 16.6 kg per carton Outside dimension of carton: 425(L)mm*306(W)mm*430(H)mm</p>	<p><b>Update Package descriptions</b></p> <p><b>10.2 Carton Package:</b></p> <div style="border: 1px solid black; padding: 5px;"> <p>Total 80 pcs Module/carton Max. weight: 17.5 kg per carton Carton: 410mm*370mm*430mm pallet size: 1140 x 890 x 135 mm, pallet Model name: M04 Size stacked: (5 * 2) * 5 layers, one pallet put 16 boxes, Total 1440 pcs module.</p> </div>																																																																																					

## 1. Operating Precautions

- 1) Display area (Polarizer) of TFT-LCD Module is easily to be damaged, please be cautious and not to scratch it.
- 2) Be sure to power off your machine before connecting or disconnecting your signal cable to TFT-LCD Module.
- 3) Wipe off water drop on display area immediately. Long contact with water may cause discoloration or spots.
- 4) When the panel surface is soiled, wipe it with absorbent cotton or soft cloth.
- 5) Display area (Glass) of TFT-LCD Module may be broken or cracked if bump Module against hard object.
- 6) To avoid ESD (Electro Static Discharge) damage, be sure to ground yourself before handling TFT-LCD Module.
- 7) Do not open nor modify the TFT-LCD module assembly.
- 8) Do not press the reflector sheet at the back of the module to any direction.
- 9) In case if TFT-LCD module has to be put back into the packing container slot after it was taken out from the container, do not press the center of the LED Reflector edge. Instead, press at the far ends of the LED Reflector edge softly. Otherwise the TFT-LCD Module may be damaged.
- 10) When inserting or removing of your signal cable to TFT-LCD Module, be sure not to apply abnormal force (rotate, tilt...etc.) to the Connector of the TFT-LCD Module.
- 11) TFT-LCD Module is not allowed to be twisted & bent even force is added on module in a very short time. Please design your display product well to avoid external force applying to module by end-user directly.
- 12) Small amount of materials without flammability grade are used in the TFT-LCD module. The TFT-LCD module should be supplied by power complied with requirements of Limited Power Source (IEC60950 or UL1950), or be applied exemption.
- 13) Severe temperature condition may result in different luminance, response time.
- 14) Continuous operating TFT-LCD Module under high temperature environment may accelerate LED light bar exhaustion and reduce luminance dramatically.
- 15) The data on this specification sheet is applicable when TFT-LCD module is placed in landscape position.
- 16) Continuous displaying fixed pattern may induce image sticking. It's recommended to use screen saver or moving content periodically if fixed pattern is displayed on the screen.

## 2. General Description

G065VN01 V2 is designed for industrial display applications with VGA (640 x RGB x 480) resolution and 16.7M (RGB 8-bits) or 262k colors (RGB 6-bits). It is composed of a TFT-LCD panel, driver ICs, control and power supply circuits board and a backlight unit including LED driving circuit. G065VN01 V2 offers LVDS interface for display signal input.

### 2.1 Display Characteristics

The following items are G065VN01 V2 characteristics summary at 25 °C(Room Temperature).

Items	Unit	Specifications
Screen Diagonal	inch	6.5
Active Area	mm	132.48(H) x 99.36(V)
Pixels H x V		640x3(RGB) x 480
Pixel Pitch	mm	0.207 x 0.207
Pixel Arrangement		R.G.B. Vertical Stripe
Display Mode		AHVA, Normally Black
Nominal Input Voltage VDD	Volt	3.3 typ.
Typical Power Consumption	Watt	2.27
Weight	Grams	170 (typ.)
Physical Size	mm	153.0(H)x 118.0(V) x 10.9(D) (typ.)
Electrical Interface		1 channel LVDS
Surface Treatment		Anit-Glare, Hardness: 3H
Support Color		16.7M / 262K colors
Temperature Range Operating Storage (Non-Operating)	°C °C	-30 to +80* -30 to +80* *Panel surface temperature
RoHS Compliance		RoHS Compliance

## 2.2 Optical Characteristics

The optical characteristics are measured under stable conditions at 25°C (Room Temperature).

Item	Unit	Conditions	Min.	Typ.	Max.	Remark
White Luminance	cd/m <sup>2</sup>	F <sub>PWM</sub> = 100% (center point)	600	800	-	Note 1
Uniformity	%	5 Points		-	1.25	Note 1, 2, 3
Contrast Ratio			700	1000	-	Note 4
Response Time	msec	Rising	-	15	20	Note 5
	msec	Falling	-	10	15	
	msec	Rising + Falling	-	25	35	
Viewing Angle	degree degree	Horizontal (Right) CR = 10 (Left)	80 80	89 89	- -	Note 6
	degree degree	Vertical (Upper) CR = 10 (Lower)	80 80	89 89	- -	
Color / Chromaticity Coordinates (CIE 1931)		White x	0.263	0.313	0.363	
		White y	0.279	0.329	0.379	
		Red x	0.554	0.604	0.654	
		Red y	0.301	0.351	0.401	
		Green x	0.277	0.327	0.377	
		Green y	0.555	0.605	0.655	
		Blue x	0.103	0.153	0.203	
		Blue y	0.063	0.113	0.163	
Color Gamut	%		50	55	-	

### Note 1: Measurement method

- Equipment      Pattern Generator, Power Supply, Digital Voltmeter, Luminance meter (SR\_3 or equivalent)
- Aperture        1° with 50cm viewing distance
- Test Point      Center
- Environment    < 1 lux

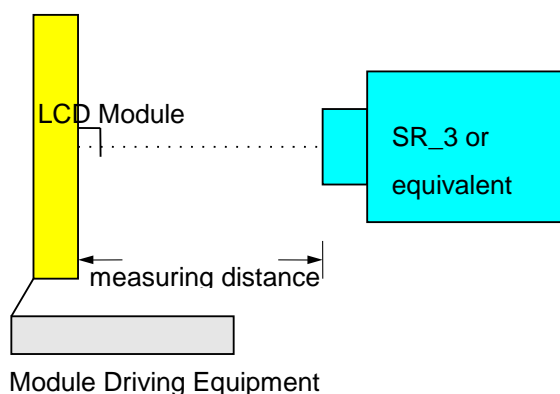

Note 2: Definition of 5 points position (Display active area: 132.48mm(W) x 99.36mm(H))

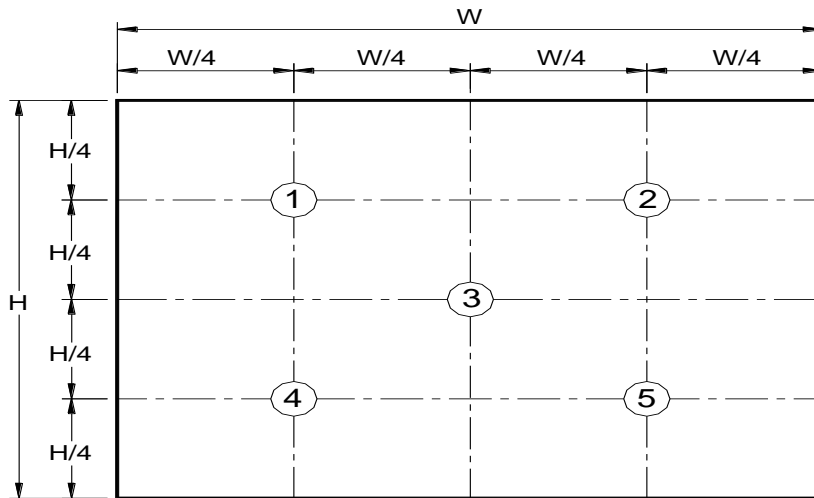

Note 3:

The luminance uniformity of 5 points is defined by dividing the maximum luminance value by the minimum luminance value at full white condition.

$$\delta_{w5} = \frac{\text{Maximum Brightness of five points}}{\text{Minimum Brightness of five points}}$$

Note 4: Definition of contrast ratio (CR):

$$\text{Contrast ratio (CR)} = \frac{\text{Brightness @ "White" state}}{\text{Brightness @ "Black" state}}$$

Note 5: Definition of response time:

The output signals of photo detector are measured when the input signals are changed from "White" to "Black" (falling time) and from "Black" to "White" (rising time), respectively. The response time interval definition is between 10% and 90% of amplitude. Please refer to the figure as below.

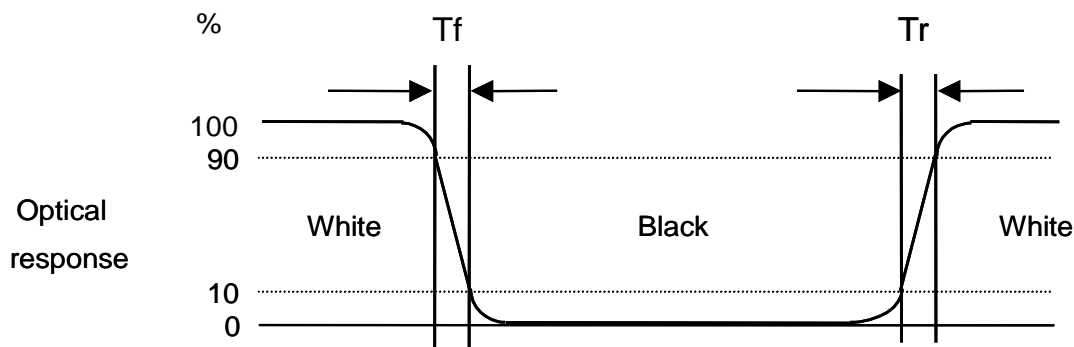



Note 6: Definition of viewing angle

Viewing angle is the measurement of contrast ratio  $\geq 10$ , at the screen center, over 180° horizontal and 180° vertical range. The 180° horizontal ( $\theta_L, \theta_R$ ) and 180° vertical ( $\phi_H, \phi_L$ ) range are illustrated as following figure.

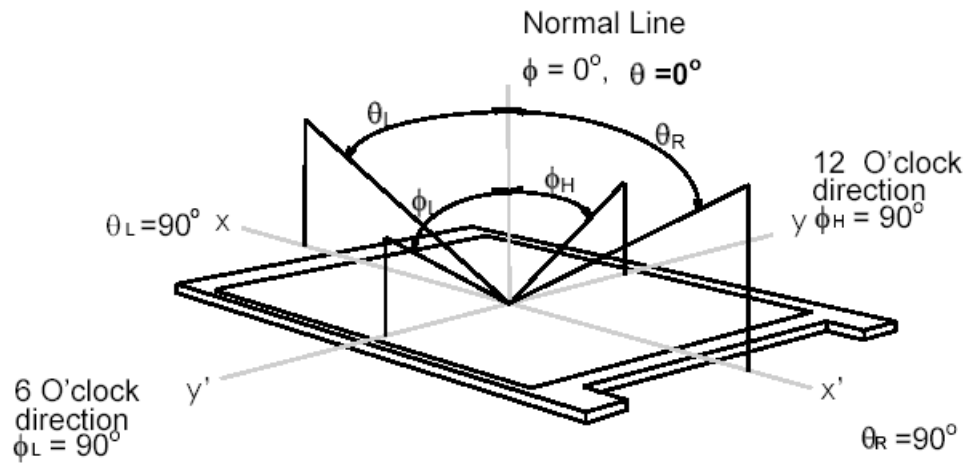

### 3. Functional Block Diagram

The following diagram shows the functional block of the G065VN01 V2 color TFT/LCD module.

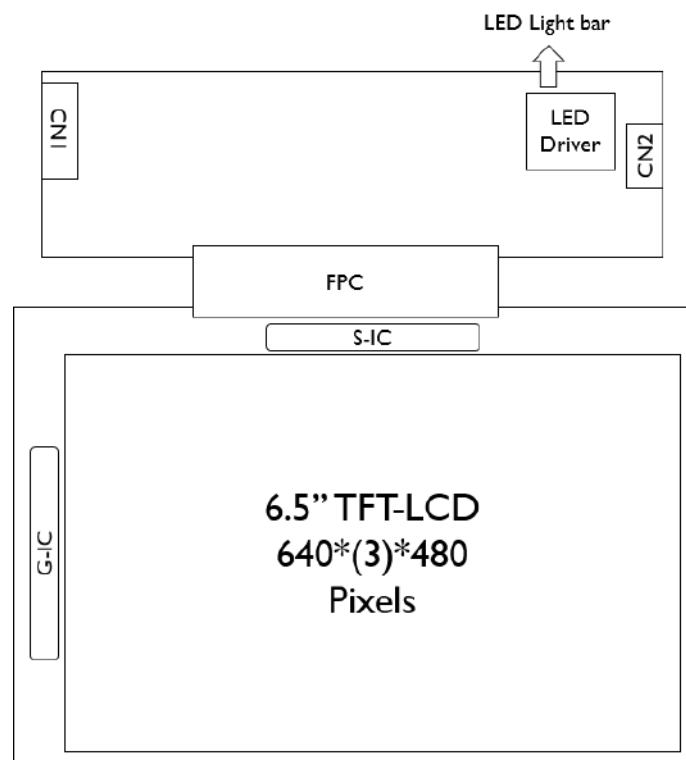

## 4. Absolute Maximum Ratings

### 4.1 Absolute Ratings

Item	Symbo	Min	Max	Unit	Remark
Logic/LCD Drive Voltage	VDD	-0.3	+3.6	Volt	Ta= 25°C
LCD Input Signal Voltage	VIN	-0.3	+3.6	Volt	Ta= 25°C
LED BLU Drive Voltage	V <sub>LED</sub>	0	16	Volt	Ta= 25°C
LED Dimming Input Voltage	V <sub>PWM</sub>	0	6	Volt	Ta= 25°C

### 4.2 Absolute Ratings of Environment

Item	Symbol	Min	Max	Unit	Remark
Operating Temperature	TOP	-30	+80*	°C	Note 1, 2
Operation Humidity	HOP	5	95	%RH	Note 1, 2
Storage Temperature	TST	-30	+80*	°C	Note 1
Storage Humidity	HST	5	95	%RH	Note 1

Note 1: Maximum Wet-Bulb should be 39°C and no condensation.

Note 2: Only operation is guaranteed. Optical and display performance should be evaluated at 25°C only.

\*: Panel surface temperature

## 5. Electrical Characteristics

### 5.1 TFT-LCD Driving

#### 5.1.1 Power Specification

Symbol	Parameter	Min	Typ	Max	Units	Remark
VDD	Logic/LCD Drive Voltage	3.0	3.3	3.5	Volt	
IDD	VDD Current	-	82	100	mA	All White Pattern (VDD=3.3V, at 60Hz)
Irush	LCD Inrush Current	-	-	1.0	A	Note 1
PDD	VDD Power	-	0.27		Watt	All White Pattern (VDD=3.3V, at 60Hz)
VDDrp	Allowable Logic/LCD Drive Ripple Voltage	-	-	100	mVp-p	All White Pattern (VDD=3.3V, at 60Hz)

Note 1: Measurement condition:

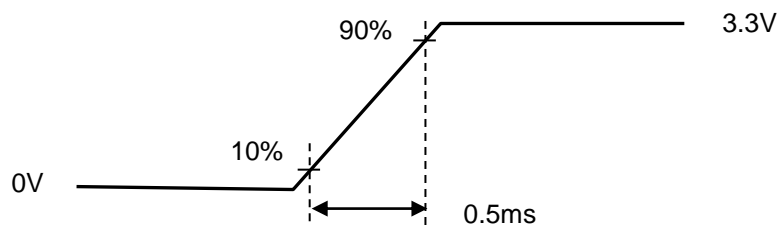
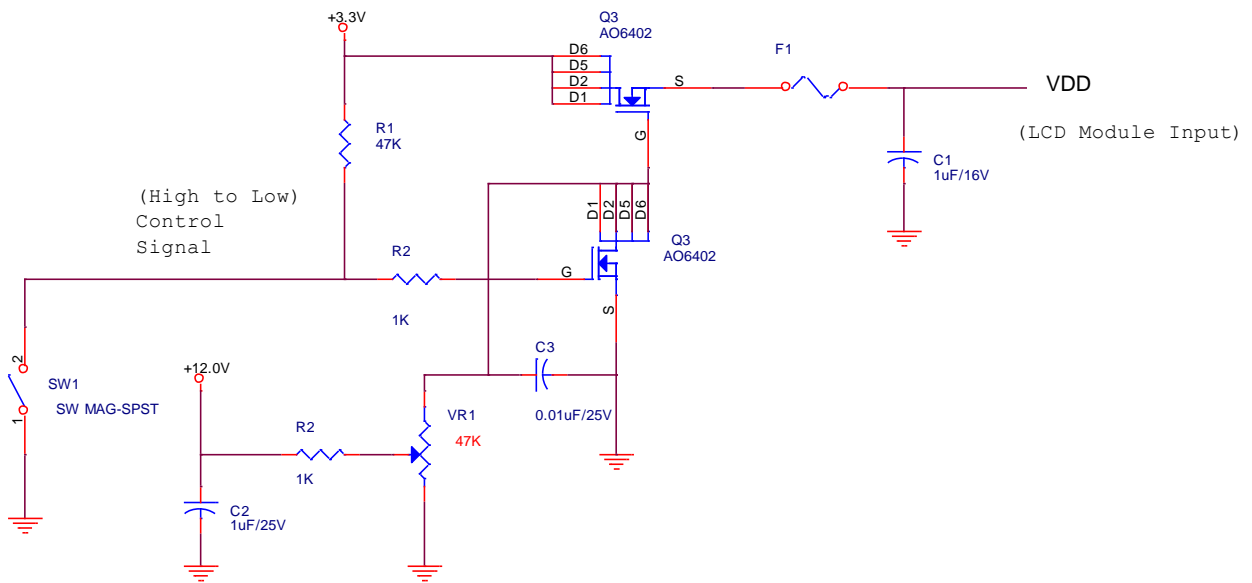

VDD rising time

AUO Display+

5.1.2 Signal Electrical Characteristics

Input signals shall be low or Hi-Z state when VDD is off.

LVDS signal (Note 1)

Parameter	Symbol	Min.	Typ.	Max.	Unit	Remark
Differential Input High Threshold	VTH	-	-	100	mV	VCM=1.20V
Differential Input Low Threshold	VTL	-100	-	-	mV	VCM=1.20V
Input Differential Voltage	VID	200	400	600	mV	
Differential Input Common Mode Voltage	VCM	1.1	-	1.45	V	VTH, VTL= ±100mV

LVDS Transmitter: THC63LVDM83A (THINE) or equivalent

Note 1: LVDS Signal Waveform.

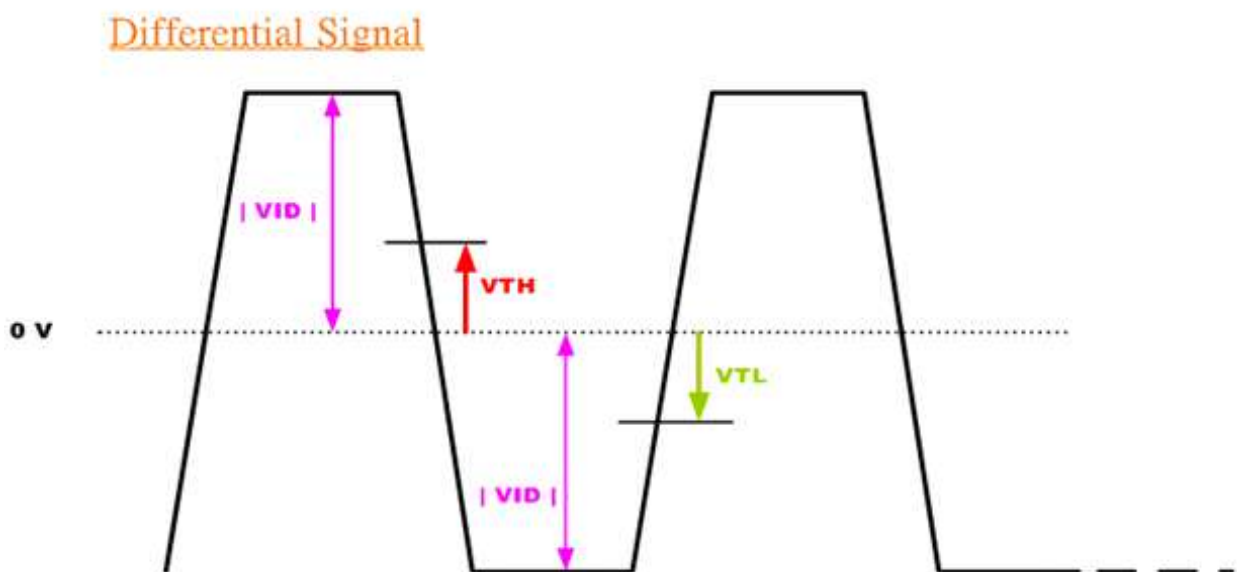
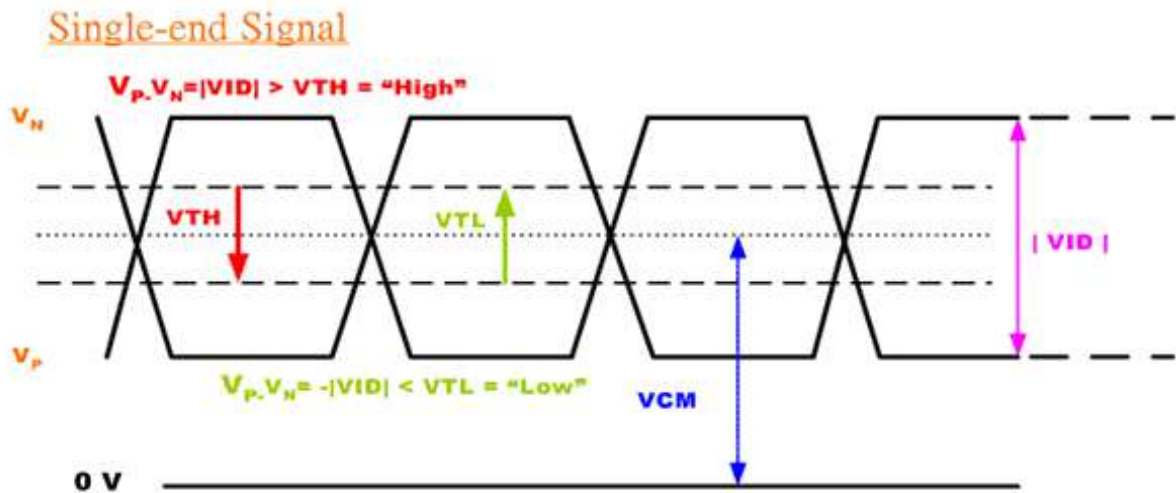

## 5.2 Backlight Unit Driving

### 5.2.1 Parameter guideline for LED driver

Following characteristics are measured under stable condition at 25°C(Room Temperature).

Symbol	Parameter	Min	Typ	Max	Units	Remark
$V_{LED}$	Input Voltage	9	12	13	Volt	
$I_{LED}$	Input Current	-	0.167		A	100% PWM duty
$P_{LED}$	Power Consumption	-	2		W	100% PWM duty
$I_{rushLED}$	Inrush Current	-	0.22	0.47	A	100% PWM duty
$V_{LED\ On/Off}$	On Control Voltage	3.0	3.3	5.0	Volt	
	Off Control Voltage	0		0.15	Volt	
$V_{PWM}$	Dimming control Voltage High	3.0	3.3	5.0	Volt	
	Dimming control Voltage Low	0		0.1	Volt	
$F_{PWM}$	Dimming Frequency	200		20K	Hz	
$D_{PWM}$	Dimming duty cycle	1		100	%	
Operating Life		70000			Hrs	Note 1, 2, 3

Note 1: If G065VN01 V2 module is driven at high ambient temperature & humidity condition. The operating life will be reduced.

Note 2: Operating life means brightness goes down to 50% initial brightness. Typical operating life time is estimated data.

Note 3: Test condition is 49mA and 25°C room temperature.

## 6. Signal Characteristic

### 6.1 Pixel Format Image

Following figure shows the relationship between input signal and LCD pixel format.

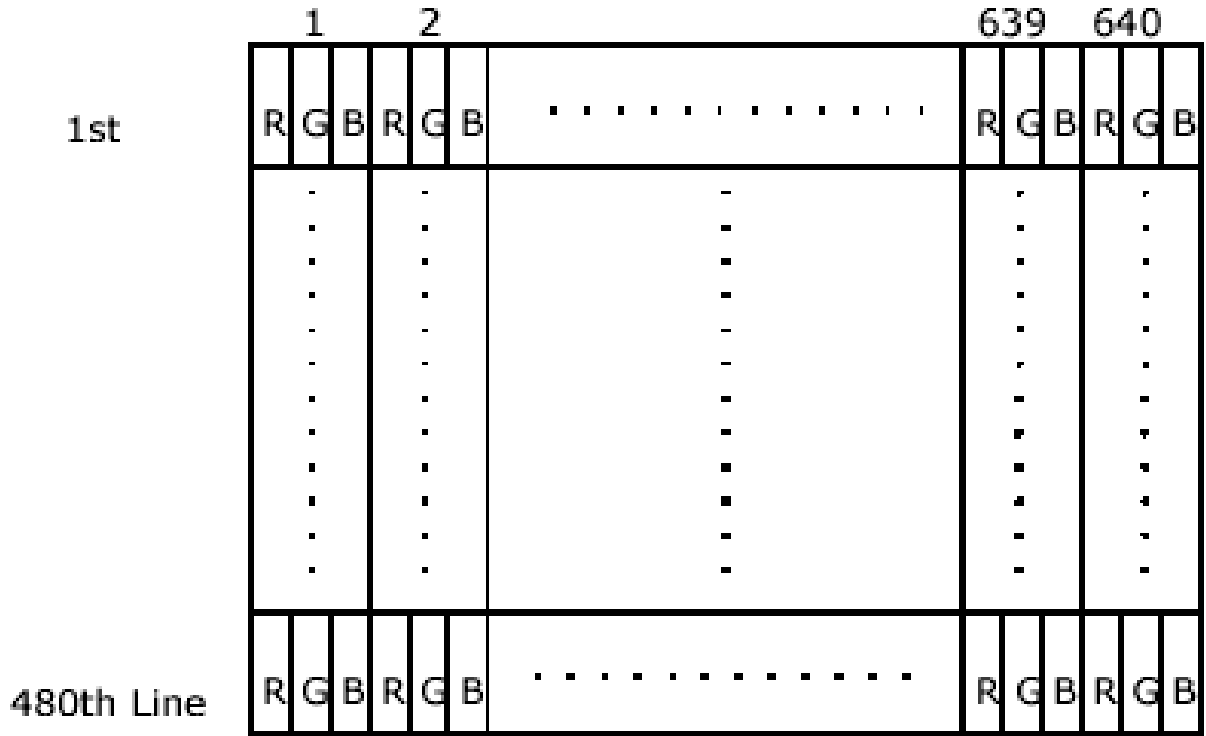

### 6.2 Scanning Direction

The following figures show the image seen from the front view. The arrow indicates the direction of scan.

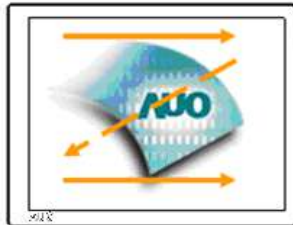

**R/L=Low or NC; U/D= Low or NC**



**R/L=High; U/D= Low or NC**

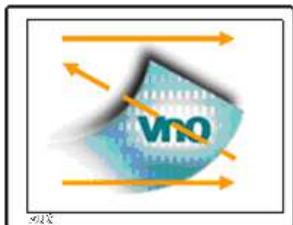

**R/L=Low or NC; U/D= High**



**R/L=High; U/D= High**

Note 1: TFT-LCD interface signal description is shown in section 6.4.

### 6.3 The Input Data Format

#### SEL68 = "Low" or "NC" for 6 bits LVDS Input

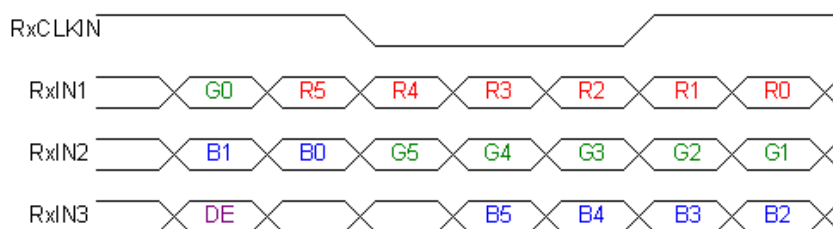

#### SEL68 = "High" for 8 bits LVDS Input

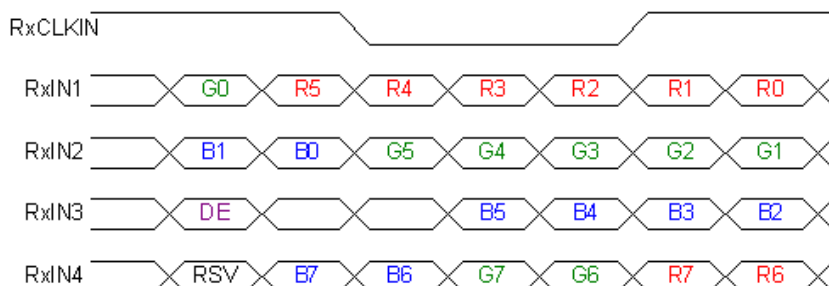

Signal Name	Description	Remark
R7	Red Data 7	Red-pixel Data
R6	Red Data 6	
R5	Red Data 5	
R4	Red Data 4	
R3	Red Data 3	
R2	Red Data 2	
R1	Red Data 1	
R0	Red Data 0	For 8Bits LVDS input MSB: R7 ; LSB: R0
G7	Green Data 7	Green-pixel Data
G6	Green Data 6	
G5	Green Data 5	
G4	Green Data 4	
G3	Green Data 3	
G2	Green Data 2	
G1	Green Data 1	
G0	Green Data 0	For 6Bits LVDS input MSB: G5 ; LSB: G0
B7	Blue Data 7	Blue-pixel Data
B6	Blue Data 6	
B5	Blue Data 5	
B4	Blue Data 4	
B3	Blue Data 3	
B2	Blue Data 2	
B1	Blue Data 1	
B0	Blue Data 0	For 8Bits LVDS input MSB: B7 ; LSB: B0
RxCLKIN	LVDS Data Clock	For 6Bits LVDS input MSB: B5 ; LSB: B0
DE	Data Enable Signal	When the signal is high, the pixel data shall be valid to be displayed.
RSV	Reserved Signal	"High" or "Low" is acceptable

Note 1: Output signals from any system shall be low or Hi-Z state when VDD is off.

## 6.4 TFT- LCD Interface Signal Description

G065VN01 V2 TFT-LCD module includes LVDS receiver. LVDS is a differential signal technology for high-speed data transfer LCD interface. LVDS Transmitter shall be THC63LVDM83A (THINE) or equivalent.

Pin No.	Symbol	Pin Description
1	VDD	Power supply, 3.3V (typical)
2	VDD	Power supply, 3.3V (typical)
3	GND	Ground
4	SEL68	Selection for either 6bit or 8bit LVDS input: SEL68 = "Low" or "NC", accepts 6bit LVDS data input; SEL68 = "High", accepts 8bit LVDS data input.
5	RxIN1-	Negative LVDS differential input (R0-R5, G0)
6	RxIN1+	Positive LVDS differential input (R0-R5, G0)
7	GND	Ground
8	RxIN2-	Negative LVDS differential input (G1-G5, B0-B1)
9	RxIN2+	Positive LVDS differential input (G1-G5, B0-B1)
10	GND	Ground
11	RxIN3-	Negative LVDS differential input (B2-B5, DE)
12	RxIN3+	Positive LVDS differential input (B2-B5, DE)
13	GND	Ground
14	RxCLKIN-	Negative LVDS differential clock input
15	RxCLKIN+	Positive LVDS differential clock input
16	NC	No connection
17	U/D	Vertical Reverse ("L" or NC: Normal, "H": Reverse)
18	R/L	Horizontal Reverse ("L" or NC: Normal, "H": Reverse)
19	RxIN4-	Negative LVDS differential input (R6-R7, G6-G7, B6-B7) VDD for 6bit LVDS input. <small>Note2</small>
20	RxIN4+	Positive LVDS differential input (R6-R7, G6-G7, B6-B7) GND for 6bit LVDS input. <small>Note2</small>

Note 1: "Low" stands for 0V. "High" stands for 3.3V. "NC" stands for "No Connection".



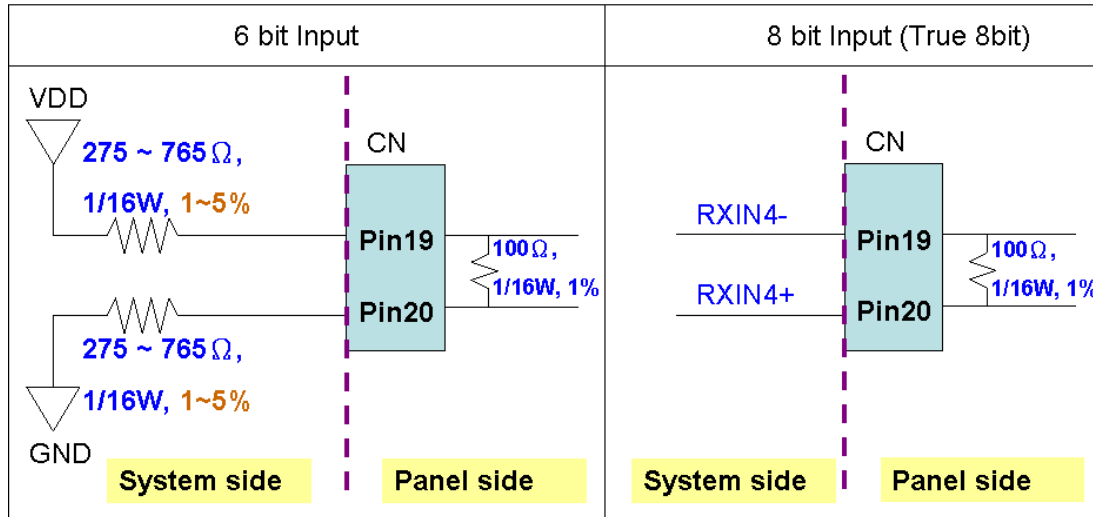

Note 2:

## 6.5 TFT- LCD Interface Timing

### 6.5.1 Timing Characteristics

DE mode only

Signal		Symbol	Min.	Typ.	Max.	Unit	Remark
Clock frequency (DOTCLK)		$1/T_{\text{CLOCK}}$	20	25.2	50	MHz	Note1
Horizontal Section	Period	$T_{\text{H}}$	770	800	1070	$T_{\text{CLOCK}}$	Note1
	Active	$T_{\text{HD}}$	640				
	Blanking	$T_{\text{HB}}$	130	160	430		
Vertical Section	Period	$T_{\text{V}}$	520	525	622	$T_{\text{LINE}}$	Note1
	Active	$T_{\text{VD}}$	480				
	Blanking	$T_{\text{VB}}$	40	45	142		

Note 1: Recommended frame rate is 60 Hz.

### 6.5.2 Input Timing Diagram

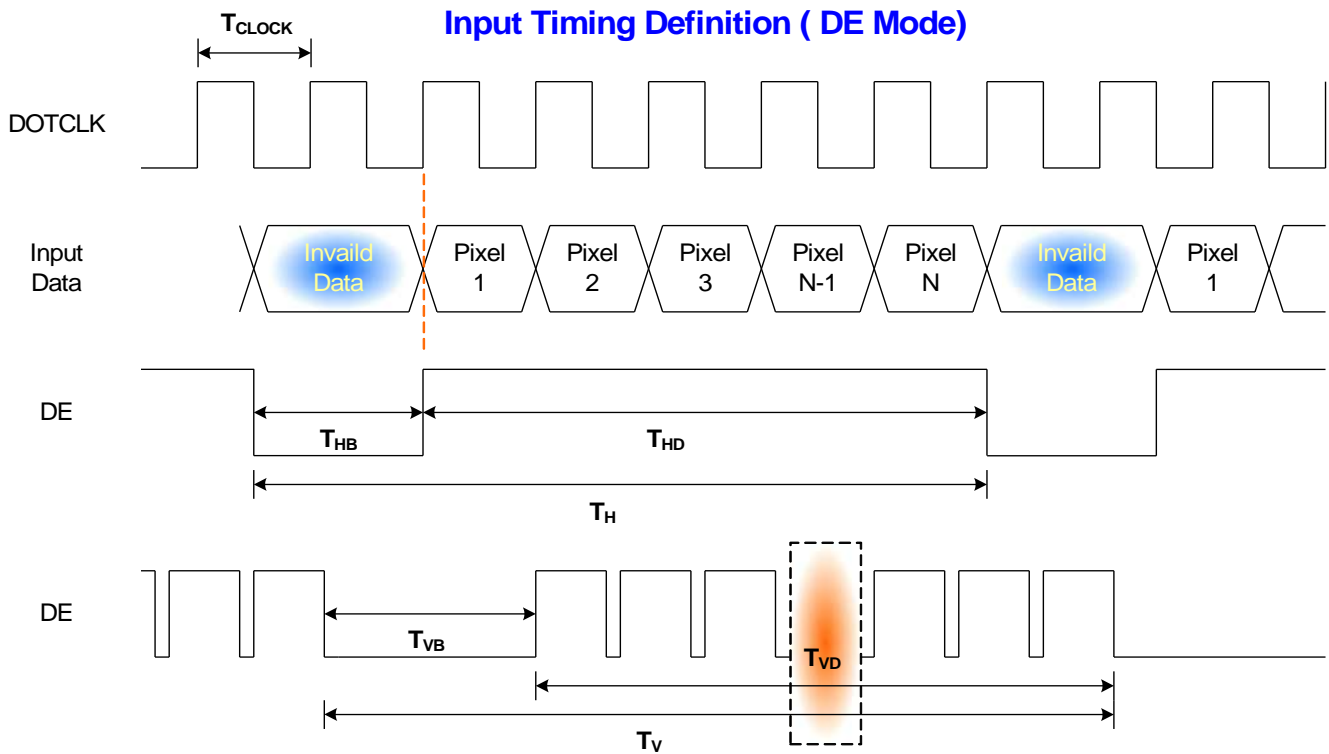

## 6.6 LED Backlight Unit Interface Signal Description

Pin #	Symbol	Pin Description
1	V <sub>LED</sub>	12V input
2	V <sub>LED</sub>	12V input
3	GND	Ground
4	GND	Ground
5	LED On/Off	3.3V-On; 0V/NC-Off
6	PWM DIM	Dimming Signal (Note2)

Note1: "NC stands for "No Connection"".

Note2: See Section 5.2.1 definition.

### 6.7 Power ON/OFF Sequence

VDD power, LCD interface signals and backlight on/off sequence are shown in the following chart. Signals from any system shall be Hi-Z state or low level when VDD is off.

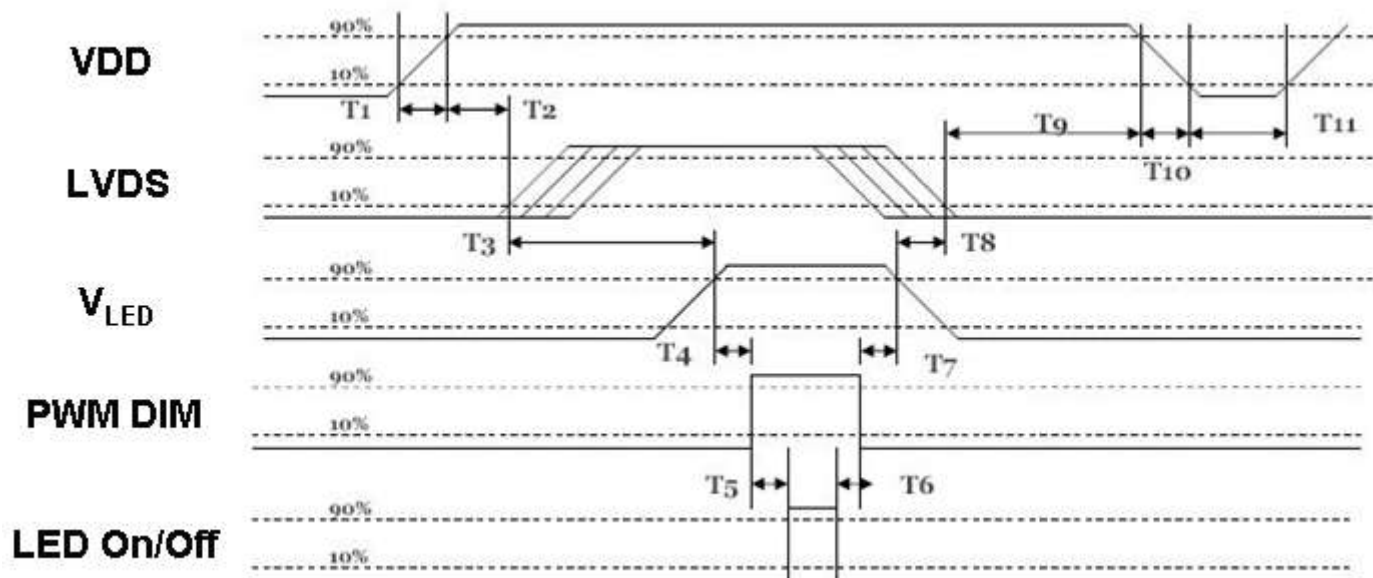

**Power ON/OFF sequence timing**

Parameter	Value			Units
	Min.	Typ.	Max.	
T1	0.5	-	3	ms
T2	30	40	50	ms
T3	200	-	-	ms
T4	10	-	-	ms
T5	10	-	-	ms
T6	0	-	-	ms
T7	10	-	-	ms
T8	100	-	-	ms
T9	0	16	50	ms
T10	-	-	10	ms
T11	1000	-	-	ms

ON/OFF sequence should be applied to avoid abnormal function in the display. Please make sure to turn off the power when you plug the cable into the input connector or pull the cable out of the connector.

## 7. Connector & Pin Assignment

### 7.1 TFT- LCD Signal (CN1): LCD Connector

<b>Manufacturer</b>	STM
<b>Connector Model Number</b>	MSB24013P20, compatible with I-PEX 20268-020E
<b>Mating Connector Model Number</b>	Hirose DF19 -20S-1C or compatible

### 7.2 LED Backlight Unit (CN2): Backlight Connector

<b>Manufacturer</b>	STM
<b>Connector Model Number</b>	MS24016RHD, compatible with MOLEX 53261-0671
<b>Mating Connector Model Number</b>	STM P24016 or compatible

### 7.3 PIN 1 definition of CN1 and CN2

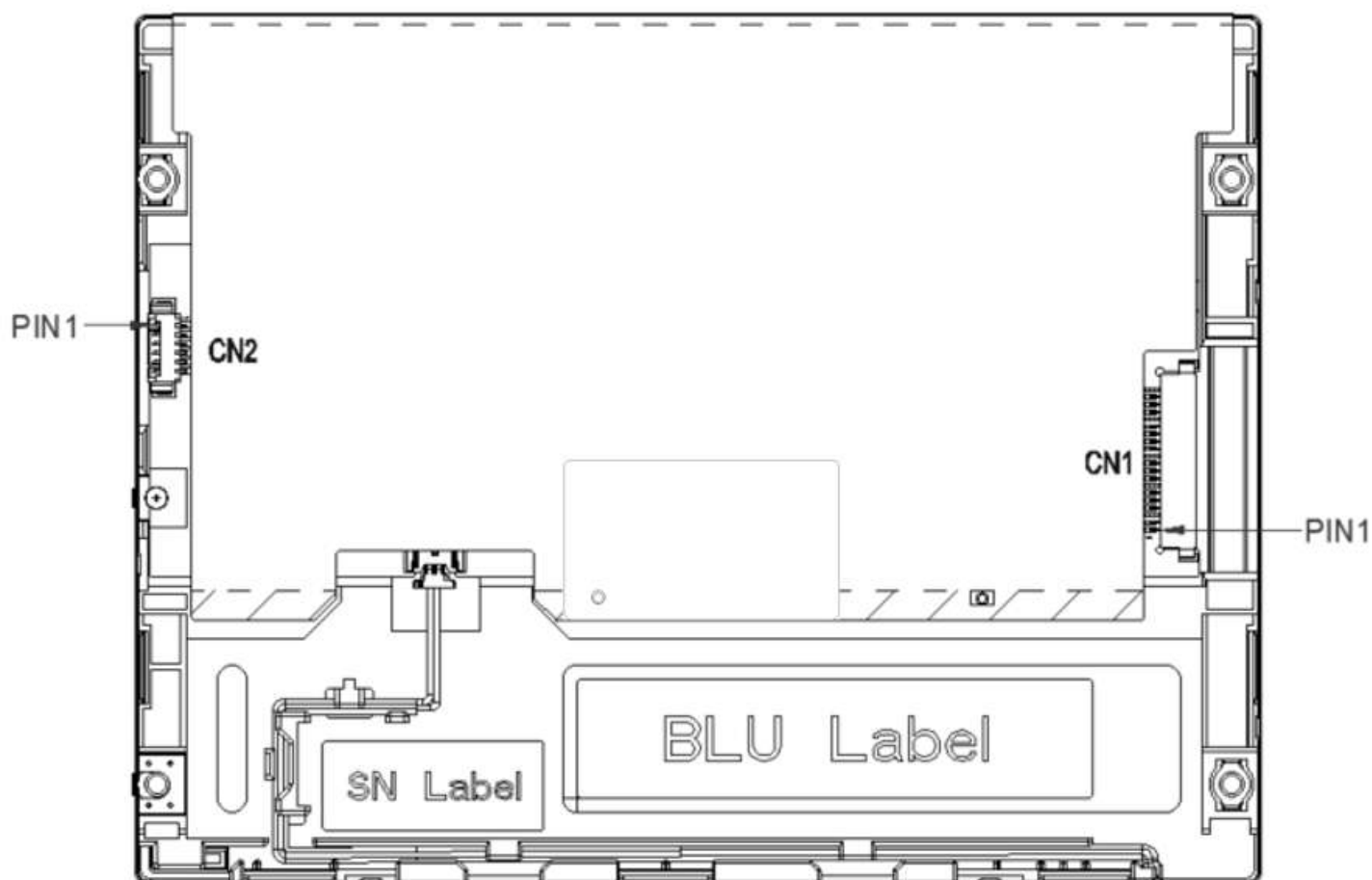

(Rear side of TFT-LCD)

## 8. Reliability Test Criteria

Items	Required Condition	Remark
Temperature Humidity Bias	60°C/90%, 300Hr	Note 2
High Temperature Operation	80°C*, 300Hr	Note 2
Low Temperature Operation	-30°C, 300Hr	Note 2
High Temperature Storage	80°C*, 300 hours	Note 2
Low Temperature Storage	-30°C, 300 hours	Note 2
Thermal Shock Test	-30°C/30 min, 80°C*/30 min, 100cycles	Note 2
Hot Start Test	80°C*/1 Hr (min.), power on/off per 5 minutes, repeat 5 times	Note 2
Cold Start Test	-30°C/1 Hr (min.), power on/off per 5 minutes, repeat 5 times	Note 2
Shock Test (Non-Operating)	50G,20ms,Half-sine wave, (±X, ±Y, ±Z)	Note 2
Vibration Test (Non-Operating)	1.5G, 10~200~10Hz, Sine wave, 30mins/axis, 3 direction (X, Y, Z)	Note 2
ESD	Contact Discharge: ±8KV, 150pF(330Ω) 1sec, 8 points, 25 times/point Air Discharge: ±15KV, 150pF(330Ω) 1sec, 8 points, 25 times/point	Note 1,2
Attitude Test	Operating: 14,000 ft, Ramp: 2000 ft/min, 8hrs Non-operating: 40,000 ft, Ramp: 2000 ft/min, 24hrs	Note 2

Note1: According to EN61000-4-2 ESD class B criteria, some performance degradation is allowed. TFT-LCD module is self-recoverable, no data lost and no hardware failures after test.

Note2:

- Water condensation is not allowed for each test items.
- Each test is done by new TFT-LCD module. Don't use the same TFT-LCD module repeatedly for reliability test.
- The reliability test is performed only to examine the TFT-LCD module capability.
- To inspect TFT-LCD module after reliability test, please store it at room temperature and room humidity for 24 hours at least in advance.

\*: Panel surface temperature

## 9. Mechanical Characteristics

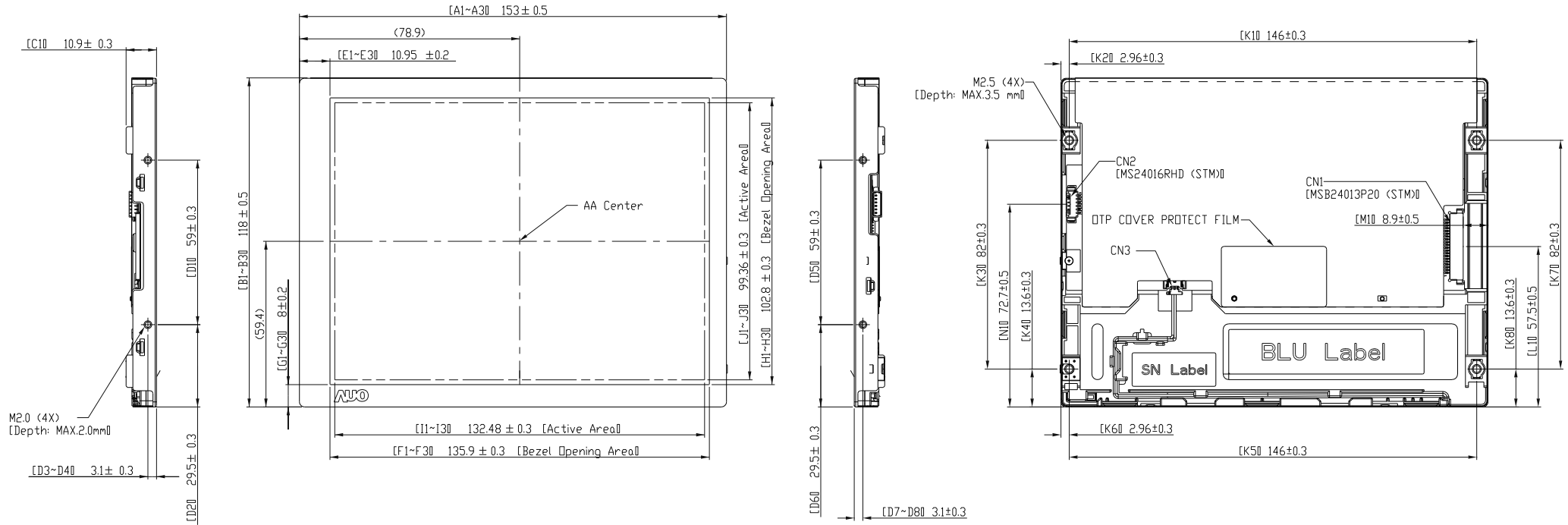

Note:  
1. Tolerances unless Marked are ±0.2mm



## 10. Label and Packaging

### 10.1 Shipping Label (on the rear side of TFT-LCD display)



### 10.2 Carton Package

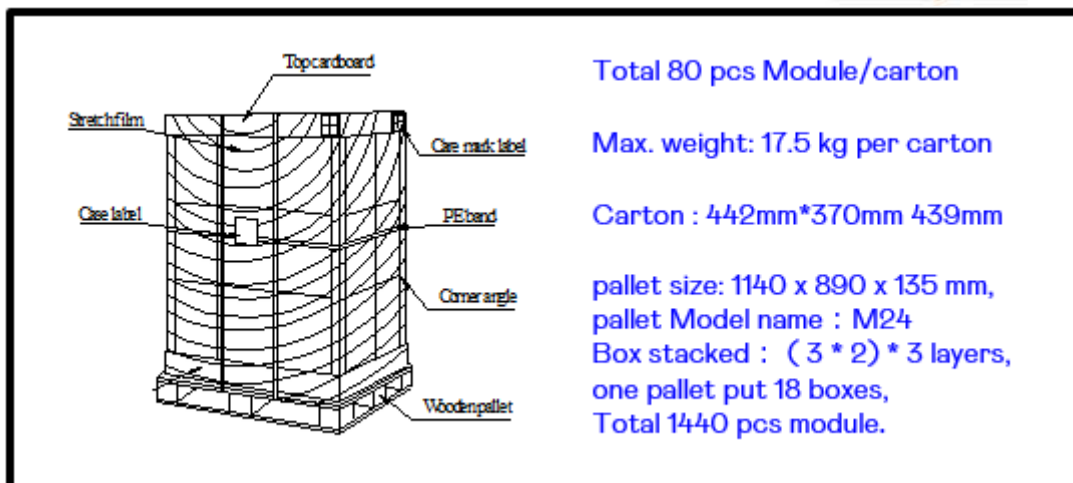
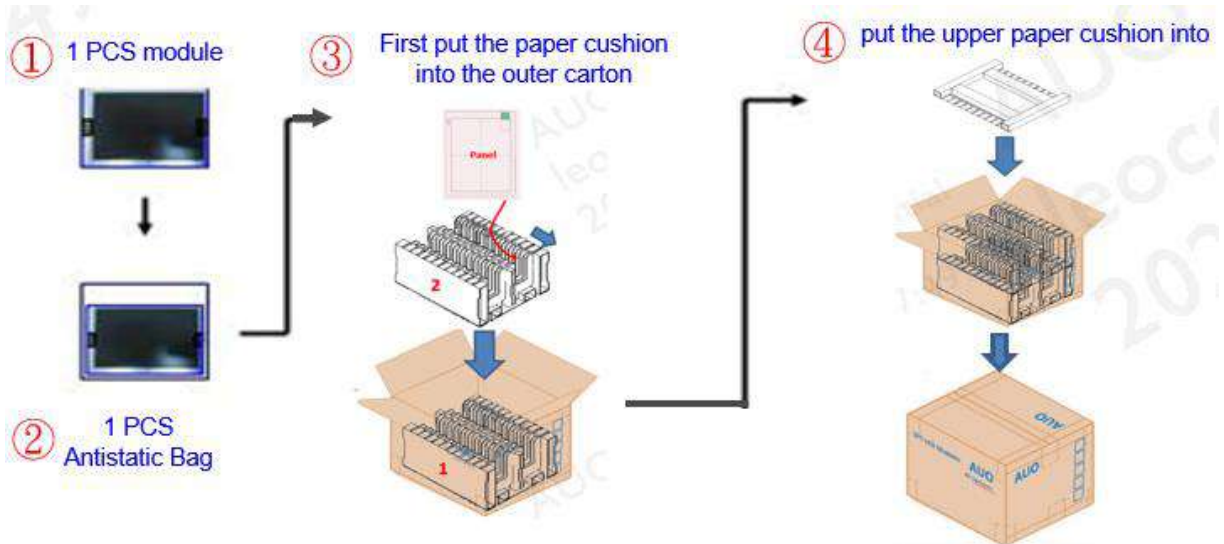

## **11 Safety**

### **11.1 Keen Edge Requirements**

There will be no keen edges or corners on the display assembly that could cause injury.

### **11.2 Materials**

#### **11.2.1 Toxicity**

There will be no carcinogenic materials used anywhere in the TFT-LCD module. If toxic materials are used, they will be reviewed and approved by the responsible AUO toxicologist.

#### **11.2.2 Flammability**

All components including electrical components that do not meet the flammability grade UL94-V1 in the TFT-LCD Module will complete the flammability rating exception approval process.

The printed circuit board will be made from material rated 94-V1 or better. The actual UL flammability rating will be printed on the printed circuit board.

### **11.3 Capacitors**

If any polarized capacitors are used in the TFT-LCD module, provisions will be made to keep them from being inserted backwards.

### **11.4 National Test Lab Requirement**

The TFT-LCD Module will satisfy all requirements for compliance to UL 60950 (U.S.A. Information Technology Equipment).