



AUO Display+

Preliminary Specification

Final Specification

<b>Module</b>	<b>5.7 Inch Color TFT-LCD</b>
<b>Model Name</b>	<b>G057VN01 V2 (97D05G02.220)</b>

<b>Customer</b>	<b>Date</b>
_____	_____
<b>Checked &amp; Approved by</b>	
_____	_____
Note: This Specification is subject to change without notice.	

<b>Approved by</b>	<b>Date</b>
LeaDer Feng	2023/05/08
<b>Prepared by</b>	
Dan Lin	2023/05/08
General Display Business Division / AU Optronics corporation	

## Contents

<b>1. Operating Precautions .....</b>	<b>4</b>
<b>2. General Description .....</b>	<b>5</b>
2.1 Display Characteristics .....	5
2.2 Optical Characteristics .....	6
<b>3. Functional Block Diagram .....</b>	<b>8</b>
<b>4. Absolute Maximum Ratings .....</b>	<b>9</b>
4.1 Absolute Ratings .....	9
4.2 Absolute Ratings of Environment.....	9
<b>5. Electrical Characteristics .....</b>	<b>10</b>
5.1 TFT-LCD Driving .....	10
5.2 Backlight Unit Driving .....	11
<b>6. Signal Characteristic.....</b>	<b>13</b>
6.1 Pixel Format Image.....	13
6.2 Scanning Direction .....	13
6.3 The Input Data Format .....	14
6.4 TFT- LCD Interface Signal Description.....	15
6.5 TFT- LCD Interface Timing .....	17
6.6 LED Backlight Unit Interface Signal Description .....	18
6.7 Power ON/OFF Sequence.....	18
<b>7. Connector &amp; Pin Assignment .....</b>	<b>20</b>
7.1 TFT- LCD Signal (CN1): LCD Connector .....	20
7.2 LED Backlight Unit (CN2): Backlight Connector.....	20
7.3 LED Light Bar Input (CN3): Light Bar Connector.....	21
7.4 PIN 1 definition of CN1 and CN2 .....	22
7.5 PIN 1 definition of CN3.....	22
<b>8. Reliability Test Criteria .....</b>	<b>23</b>
<b>9. Mechanical Characteristics .....</b>	<b>24</b>
<b>10. Label and Packaging .....</b>	<b>25</b>
10.1 Shipping Label (on the rear side of TFT-LCD display) .....	25
10.2 Carton Package .....	25
<b>11 Safety .....</b>	<b>25</b>
11.1 Keen Edge Requirements.....	26
11.2 Materials .....	26
11.3 Capacitors .....	26
11.4 National Test Lab Requirement.....	26

### Record of Revision

Version and Date	Page	Old description	New Description	Remark
0.0 2023/01/13	All		First edition Preliminary specifications	
0.1 2023/03/01	22		Update Rear side 2D drawing 	
	24		Update Rear side 2D drawing 	
1.0 2023/03/30	All		First edition Final specifications	
1.1 2023/05/08	25		Update Shipping label format 	
1.2 2024/03/04	24		Update to show 2D drawing version. 	

## 1. Operating Precautions

- 1) Display area (Polarizer) of TFT-LCD Module is easily to be damaged, please be cautious and not to scratch it.
- 2) Be sure to power off your machine before connecting or disconnecting your signal cable to TFT-LCD Module.
- 3) Wipe off water drop on display area immediately. Long contact with water may cause discoloration or spots.
- 4) When the panel surface is soiled, wipe it with absorbent cotton or soft cloth.
- 5) Display area (Glass) of TFT-LCD Module may be broken or cracked if bump Module against hard object.
- 6) To avoid ESD (Electro Static Discharge) damage, be sure to ground yourself before handling TFT-LCD Module.
- 7) Do not open nor modify the TFT-LCD module assembly.
- 8) Do not press the reflector sheet at the back of the module to any direction.
- 9) In case if TFT-LCD module has to be put back into the packing container slot after it was taken out from the container, do not press the center of the LED Reflector edge. Instead, press at the far ends of the LED Reflector edge softly. Otherwise the TFT-LCD Module may be damaged.
- 10) When inserting or removing of your signal cable to TFT-LCD Module, be sure not to apply abnormal force (rotate, tilt...etc.) to the Connector of the TFT-LCD Module.
- 11) TFT-LCD Module is not allowed to be twisted & bent even force is added on module in a very short time. Please design your display product well to avoid external force applying to module by end-user directly.
- 12) Small amount of materials without flammability grade are used in the TFT-LCD module. The TFT-LCD module should be supplied by power complied with requirements of Limited Power Source (IEC60950 or UL1950), or be applied exemption.
- 13) Severe temperature condition may result in different luminance, response time.
- 14) Continuous operating TFT-LCD Module under high temperature environment may accelerate LED light bar exhaustion and reduce luminance dramatically.
- 15) The data on this specification sheet is applicable when TFT-LCD module is placed in landscape position.
- 16) Continuous displaying fixed pattern may induce image sticking. It's recommended to use screen saver or moving content periodically if fixed pattern is displayed on the screen.

## 2. General Description

G057VN01 V2 is designed for industrial display applications with VGA (640 x RGB x 480) resolution and 262k colors (RGB 6-bits). It is composed of a TFT-LCD panel, driver ICs, control and power supply circuits board and backlight unit including LED driver circuit. G057VN01 V2 offers CMOS interface for display signal input.

### 2.1 Display Characteristics

The following items are G057VN01 V2 characteristics summary at 25 °C (Room Temperature).

Items	Unit	Specifications
Screen Diagonal	inch	5.7
Active Area	mm	115.2(H) x 86.4(V)
Pixels H x V		640 x 3(RGB) x 480
Pixel Pitch	mm	0.18 x 0.18
Pixel Arrangement		R.G.B. Vertical Stripe
Display Mode		AHVA, Normally black
Nominal Input Voltage VDD	Volt	3.3 typ.
Typical Power Consumption	Watt	2.35W (LCD:0.35W/LED BLU: 2.0W) @ All white pattern, Full Load and $V_{LED}=12V$
Weight	Grams	150g (typ.), 165g (max.)
Physical Size	mm	144.0(H)x 104.6(V) x 12.3(D) (typ.)
Electrical Interface		Digital 6-bit Parallel RGB
Surface Treatment		Anti-Glare, Hardness 3H
Support Color		262K colors
Temperature Range		
Operating	°C	-30 to +85
Storage (Non-Operating)	°C	-30 to +85
RoHS Compliance		RoHS Compliance

## 2.2 Optical Characteristics

The optical characteristics are measured under stable conditions at 25°C (Room Temperature).

Item	Unit	Conditions	Min.	Typ.	Max.	Remark
White Luminance	cd/m <sup>2</sup>	V <sub>LED</sub> = 12V, D <sub>PWM</sub> = 100% (center point)	525	700	-	Note 1
Uniformity	%	5 Points	75	-	-	Note 1, 2, 3
Contrast Ratio			800	1000	-	Note 4
Response Time	msec	Rising	-	15	20	Note 5
	msec	Falling	-	10	15	
	msec	Rising + Falling	-	25	35	
Viewing Angle	degree	Horizontal (Right)	80	89	-	Note 6
	degree	Horizontal (Left)	80	89	-	
	degree	Vertical (Upper)	80	89	-	
	degree	Vertical (Lower)	80	89	-	
Color / Chromaticity Coordinates (CIE 1931)		White x	0.263	0.313	0.363	
		White y	0.279	0.329	0.379	
		Red x	0.538	0.588	0.638	
		Red y	0.293	0.343	0.393	
		Green x	0.287	0.337	0.387	
		Green y	0.536	0.586	0.636	
		Blue x	0.109	0.159	0.209	
	Blue y	0.069	0.119	0.169		
Color Gamut	%		-	50	-	

### Note 1: Measurement method

Equipment      Pattern Generator, Power Supply, Digital Voltmeter, Luminance meter (SR\_3 or equivalent)

Aperture        1° with 50cm viewing distance

Test Point      Center

Environment    < 1 lux

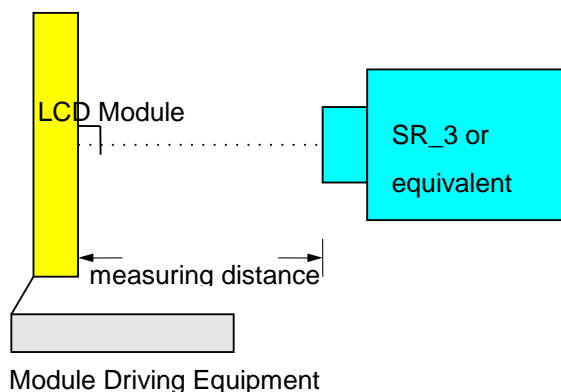

Note 2: Definition of 5 points position (Display active area: 115.2mm(W) x 86.4mm(H))

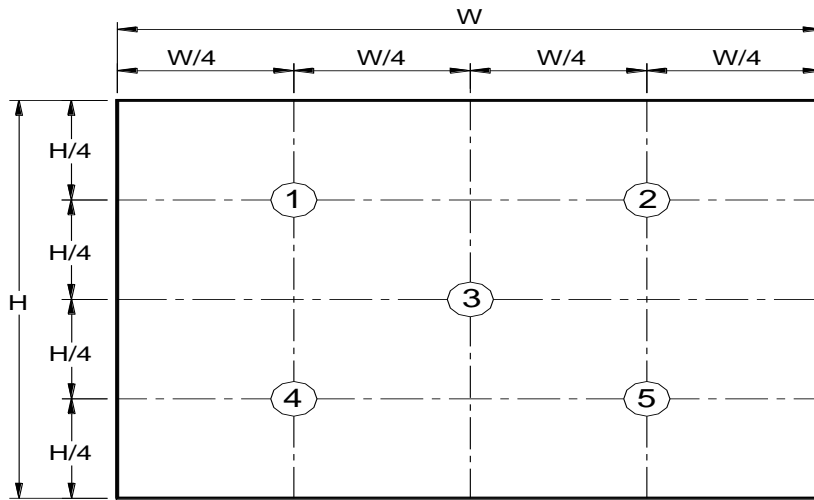

Note 3:

The luminance uniformity of 5 points is defined by dividing the minimum luminance value by the maximum luminance value at full white condition.

$$\delta_{w5} = \frac{\text{Minimum Brightness of five points}}{\text{Maximum Brightness of five points}}$$

Note 4: Definition of contrast ratio (CR):

$$\text{Contrast ratio (CR)} = \frac{\text{Brightness @ "White" state}}{\text{Brightness @ "Black" state}}$$

Note 5: Definition of response time:

The output signals of photo detector are measured when the input signals are changed from "White" to "Black" (falling time) and from "Black" to "White" (rising time), respectively. The response time interval definition is between 10% and 90% of amplitude. Please refer to the figure as below.

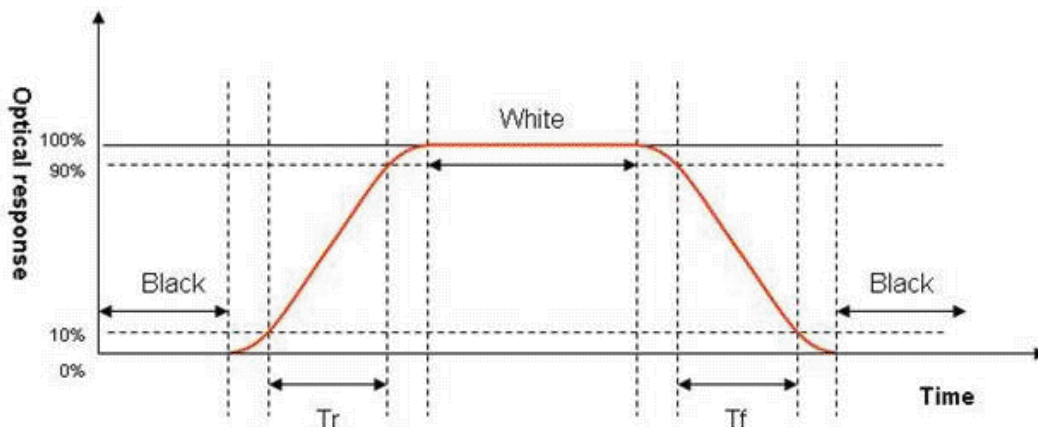

Note 6: Definition of viewing angle

Viewing angle is the measurement of contrast ratio  $\geq 10$ , at the screen center, over 180° horizontal and 180° vertical range. The 180° horizontal ( $\theta_L, \theta_R$ ) and 180° vertical ( $\phi_H, \phi_L$ ) range are illustrated as following figure.

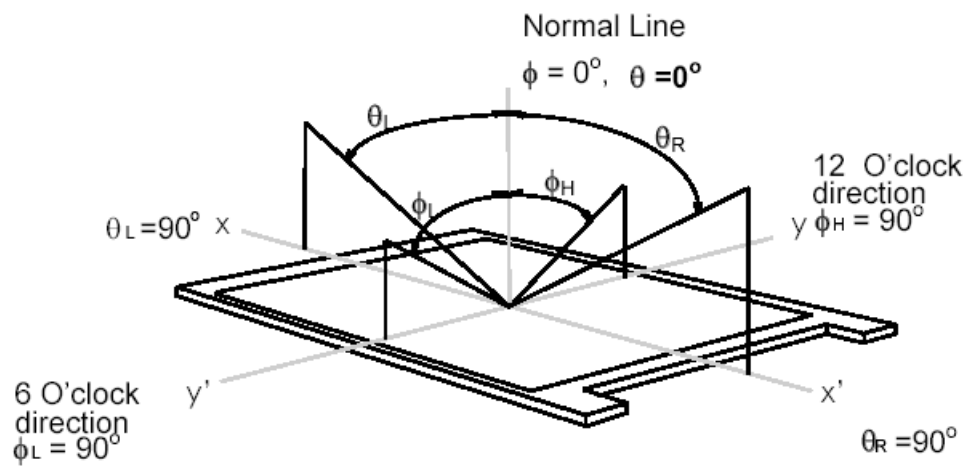

### 3. Functional Block Diagram

The following diagram shows the functional block of the G057VN01 V2 color TFT/LCD module.

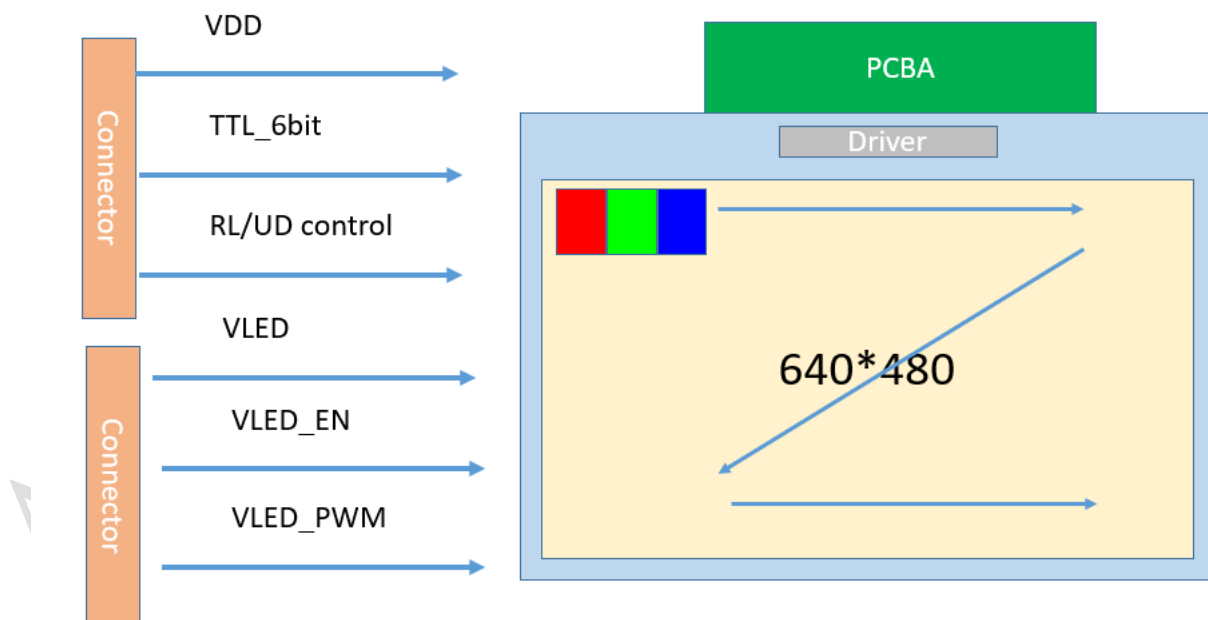



## 4. Absolute Maximum Ratings

### 4.1 Absolute Ratings

Item	Symbol	Min	Max	Unit	Remark
Logic/LCD Drive Voltage	VDD	-0.3	+3.6	Volt	Ta= 25°C
LED BLU Drive Voltage	VLED	0	23	Volt	Ta= 25°C
LED Dimming Input	VLED_PWM	0	23	Volt	Ta= 25°C

### 4.2 Absolute Ratings of Environment

Item	Symbol	Min	Max	Unit	Remark
Operating Temperature	TOP	-30	+85	°C	Note 1, 2
Operation Humidity	HOP	5	95	%RH	Note 1, 2
Storage Temperature	TST	-30	+85	°C	Note 1
Storage Humidity	HST	5	95	%RH	Note 1

Note 1: Maximum Wet-Bulb should be 39°C and no condensation.

Note 2: Only operation is guaranteed. Optical performance should be evaluated at 25°C only.

## 5. Electrical Characteristics

### 5.1 TFT-LCD Driving

#### 5.1.1 Power Specification

Symbol	Parameter	Min	Typ	Max	Units	Remark
VDD	Logic/LCD Drive Voltage	3.0	3.3	3.5	Volt	
I_VDD	VDD Current	-	90	106	mA	All white Pattern (VDD=3.3V, at 60Hz)
P_VDD	VDD Power	-	0.30	0.35	Watt	All white Pattern (VDD=3.3V, at 60Hz)
Irush	LCD Inrush Current	-	-	1	A	Note 1
VDDrp	Allowable Logic/LCD Drive Ripple Voltage	-	-	550	mVp-p	All white Pattern (VDD=3.3V, at 60Hz)

Note 1: Measurement condition:

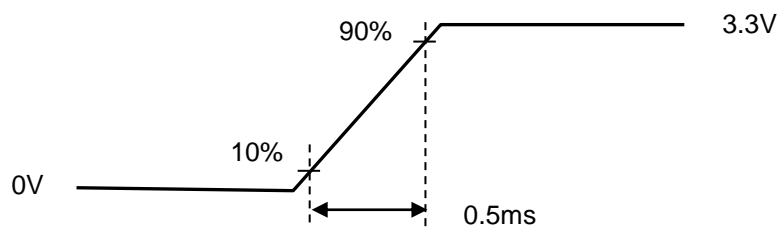
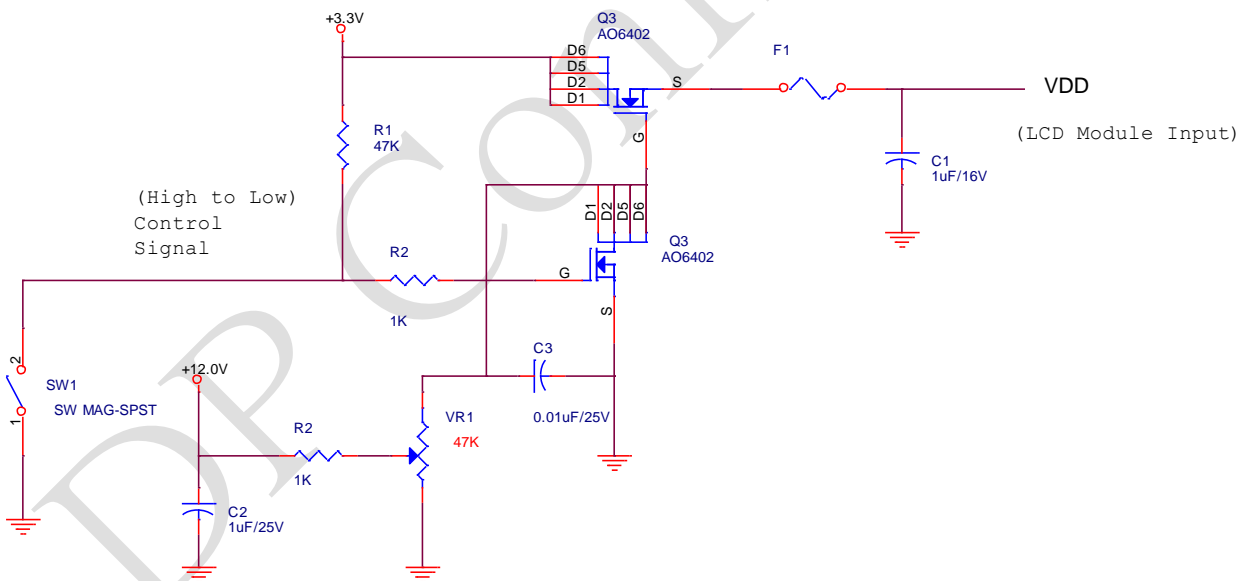

VDD rising time

### 5.1.2 Signal Electrical Characteristics

Input signals shall be low or Hi-Z state when VDD is off.

Parameter		Symbol	Min.	Typ.	Max.	Unit	Remarks
Logic Input Voltage for Display Signals	High	VIH	0.7VDD	-	VDD	Volt	
	Low	VIL	0	-	0.3VDD	Volt	
Input Voltage for RL/UD	High	VIH	0.7VDD	-	VDD	Volt	
	Low	VIL	0	-	0.3VDD	Volt	

## 5.2 Backlight Unit Driving

### 5.2.1 Parameter guideline for LED

Following characteristics are measured under stable condition using a LED driving board at 25°C(Room Temperature)

Symbol	Parameter	Min	Typ	Max	Units	Remark
VLED	Input Voltage	9	12	20	Volt	
I <sub>VLED</sub>	Input Current	-	0.13	0.17	A	V <sub>LED</sub> =12V, D <sub>PWM</sub> =100%
P <sub>VLED</sub>	Power Consumption	-	1.56	2.0	Watt	V <sub>LED</sub> =12V, D <sub>PWM</sub> =100%
I <sub>rushVLED</sub>	Inrush Current	-		1	A	V <sub>LED</sub> =12V, D <sub>PWM</sub> =100%
VLED_PWM	Dimming control Voltage High	1.3	3.3	5.0	Volt	Note 1,2
	Dimming control Voltage Low	-	-	0.7	Volt	
F <sub>VLED_PWM</sub>	Dimming Frequency	200		20K	Hz	
D <sub>VLED_PWM</sub>	Dimming duty cycle	1		100	%	
VLED_EN	On Control Voltage	1.3	3.3	5.0	Volt	Note 3, 4
	Off Control Voltage	-	-	0.7	Volt	
I <sub>F</sub>	LED Forward Current		45		mA	Ta = 25oC
V <sub>F</sub>	LED Forward Voltage		30	34		I <sub>F</sub> = 45mA, Ta = 25oC
P <sub>LVED</sub>	LED Power		1.35	1.53	Watt	
Operating Life		70000	-	-	Hrs	Note 5, 6, 7

Note 1: The PWM dimming function can be operated by PWM signal.

The PWM duty operated in 5~100% will have better accuracy

The PWM duty cycle can adjust white Luminance.(PWM High: ON and PWM Low: OFF)

Note 2: PWM signal can not be floating and pull-down to ground when waiting.

Note 3: Enable (VLED\_EN) must be turned on late than VLED and PWM Signal.

Note 4: Enable (VLED\_EN) must be turned off early than VLED and PWM Signal.

Note 5: If G057VN01 V2 module is driven by high current or at high ambient temperature & humidity condition. The

**AUO Display+**

operating life will be reduced.

Note 6: Operating life means brightness goes down to 50% initial brightness. Minimum operating life time is estimated data.

Note 7: Test condition is 45mA of each LED and 25°C room temperature.

Note 8: See Section 6.6 for LED Backlight Unit Interface Signal Description

ADP Confidential

## 6. Signal Characteristic

### 6.1 Pixel Format Image

Following figure shows the relationship between input signal and LCD pixel format.

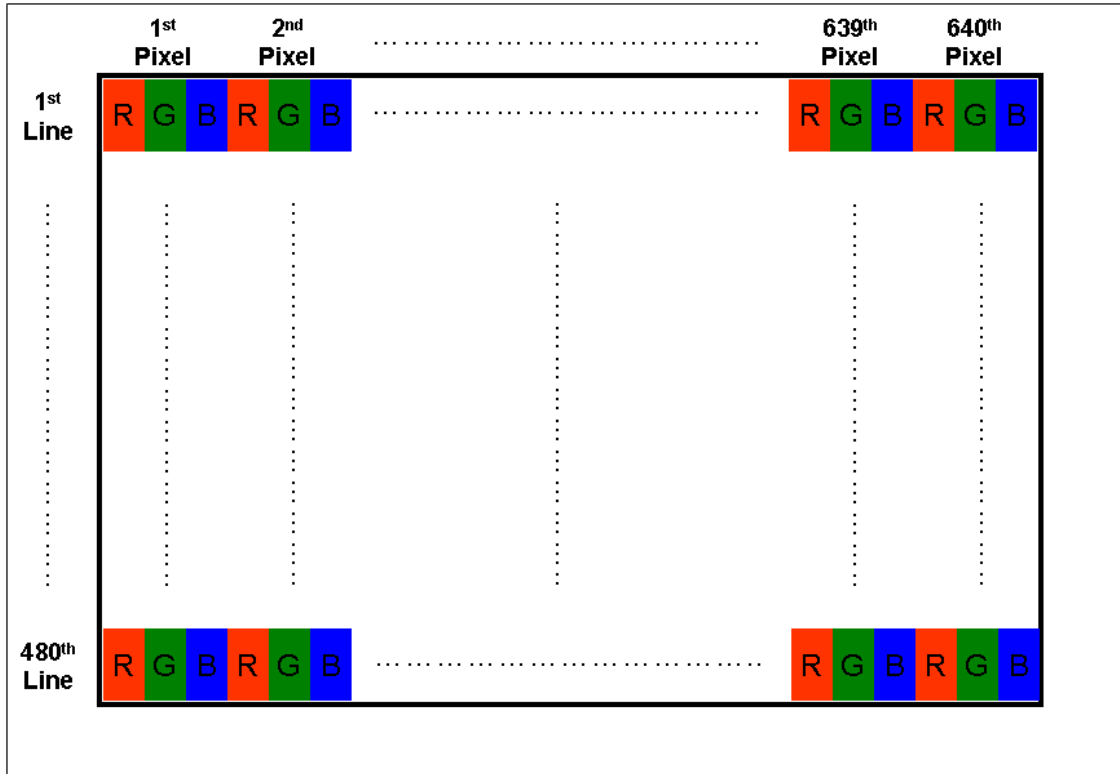

### 6.2 Scanning Direction

The following figures show the image seen from the front view. The arrow indicates the direction of scan.



R/L=Low or NC; U/D=High or NC

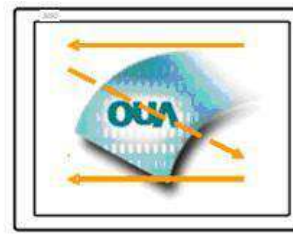

R/L=High; U/D=High or NC



R/L=Low or NC; U/D=Low



R/L=High; U/D=Low

Note 1: TFT-LCD interface signal description is shown in section 6.4.

### 6.3 The Input Data Format

This product displays 262,144 colors in terms of the 64 grey levels on RGB respectively. The following table demonstrates the display of input data.

Display colors		Data signal (0 : Low level, 1: High level)																	
		R5	R4	R3	R2	R1	R0	G5	G4	G3	G2	G1	G0	B5	B4	B3	B2	B1	B0
Basic colors	Black	0	0	0	0	0	0	0	0	0	0	0	0	0	0	0	0	0	0
	Blue	0	0	0	0	0	0	0	0	0	0	0	0	1	1	1	1	1	1
	Red	1	1	1	1	1	1	0	0	0	0	0	0	0	0	0	0	0	0
	Magenta	1	1	1	1	1	1	0	0	0	0	0	0	1	1	1	1	1	1
	Green	0	0	0	0	0	0	1	1	1	1	1	1	0	0	0	0	0	0
	Cyan	0	0	0	0	0	0	1	1	1	1	1	1	1	1	1	1	1	1
	Yellow	1	1	1	1	1	1	1	1	1	1	1	1	0	0	0	0	0	0
	White	1	1	1	1	1	1	1	1	1	1	1	1	1	1	1	1	1	1
Red grayscale	Black	0	0	0	0	0	0	0	0	0	0	0	0	0	0	0	0	0	0
	Dark	0	0	0	0	1	0	0	0	0	0	0	0	0	0	0	0	0	0
	↑																		
	↓																		
	bright	1	1	1	1	0	1	0	0	0	0	0	0	0	0	0	0	0	0
Red	1	1	1	1	1	1	0	0	0	0	0	0	0	0	0	0	0	0	
Green grayscale	Black	0	0	0	0	0	0	0	0	0	0	0	0	0	0	0	0	0	0
	Dark	0	0	0	0	0	0	0	0	0	0	1	0	0	0	0	0	0	0
	↑																		
	↓																		
	bright	0	0	0	0	0	0	1	1	1	1	0	1	0	0	0	0	0	0
Green	0	0	0	0	0	0	1	1	1	1	1	1	0	0	0	0	0	0	
Blue grayscale	Black	0	0	0	0	0	0	0	0	0	0	0	0	0	0	0	0	0	0
	Dark	0	0	0	0	0	0	0	0	0	0	0	0	0	0	0	0	1	0
	↑																		
	↓																		
	bright	0	0	0	0	0	0	0	0	0	0	0	0	1	1	1	1	0	1
Blue	0	0	0	0	0	0	0	0	0	0	0	0	1	1	1	1	1	0	
Blue	0	0	0	0	0	0	0	0	0	0	0	0	1	1	1	1	1	1	

### 6.4 TFT- LCD Interface Signal Description

Pin#	Symbol	Pin Description
1	GND	Ground
2	CLK	Dot clock
3	NC	Reserved for internal test. Please treat it as no Connect.
4	NC	Reserved for internal test. Please treat it as no Connect.
5	GND	Ground
6	R0	Red data(LSB)
7	R1	Red data
8	R2	Red data
9	R3	Red data
10	R4	Red data
11	R5	Red data(MSB)
12	GND	Ground
13	G0	Green data(LSB)
14	G1	Green data
15	G2	Green data
16	G3	Green data
17	G4	Green data
18	G5	Green data(MSB)
19	GND	Ground
20	B0	Blue data(LSB)
21	B1	Blue data
22	B2	Blue data
23	B3	Blue data
24	B4	Blue data
25	B5	Blue data(MSB)
26	GND	Ground
27	DE	Data Enable signal
28	VDD	Power Supply
29	VDD	Power Supply
30	R/L	Horizontal scan Normal: L or NC, Reverse: H
31	U/D	Vertical scan Normal: H or NC, Reverse: L

32	NC	Reserved for internal test. Please treat it as no Connect.
33	GND	Ground

Note 1: "Low" stands for 0V. "High" stands for 3.3V. "NC" stands for "No Connection".

ADP Confidential



## 6.5 TFT- LCD Interface Timing

### 6.5.1 Timing Characteristics

DE mode only

Signal		Symbol	Min.	Typ.	Max.	Unit	Remark
Clock frequency (DOTCLK)		$1/T_{\text{CLOCK}}$	23.9	25.2	34.2	MHz	Note1
Data	Setup Time	$T_{\text{dsu}}$	8	-	-	ns	RL, GL, BL to DCLK
	Hold Time	$T_{\text{dhd}}$	8	-	-	ns	
DE	Setup Time	$T_{\text{esu}}$	8	-	-	ns	
Horizontal Section	Period	$T_{\text{H}}$	770	800	1000	$T_{\text{CLOCK}}$	Note1
	Active	$T_{\text{HD}}$	640				
	Blanking	$T_{\text{HB}}$	130	160	360		
Vertical Section	Period	$T_{\text{V}}$	516	525	570	$T_{\text{LINE}}$	Note1
	Active	$T_{\text{VD}}$	480				
	Blanking	$T_{\text{VB}}$	36	45	90		

Note 1: Recommended frame rate is 60 Hz.

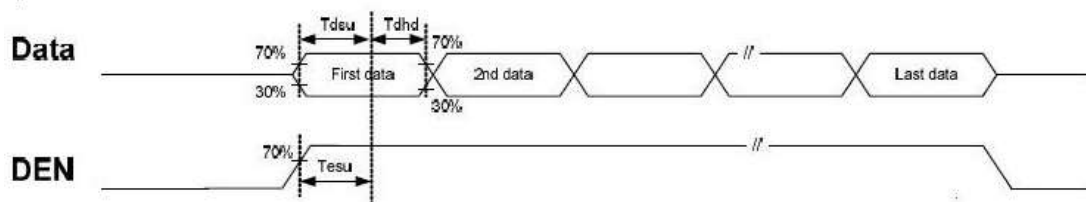

### 6.5.2 Input Timing Diagram

#### Input Timing Definition ( DE Mode)

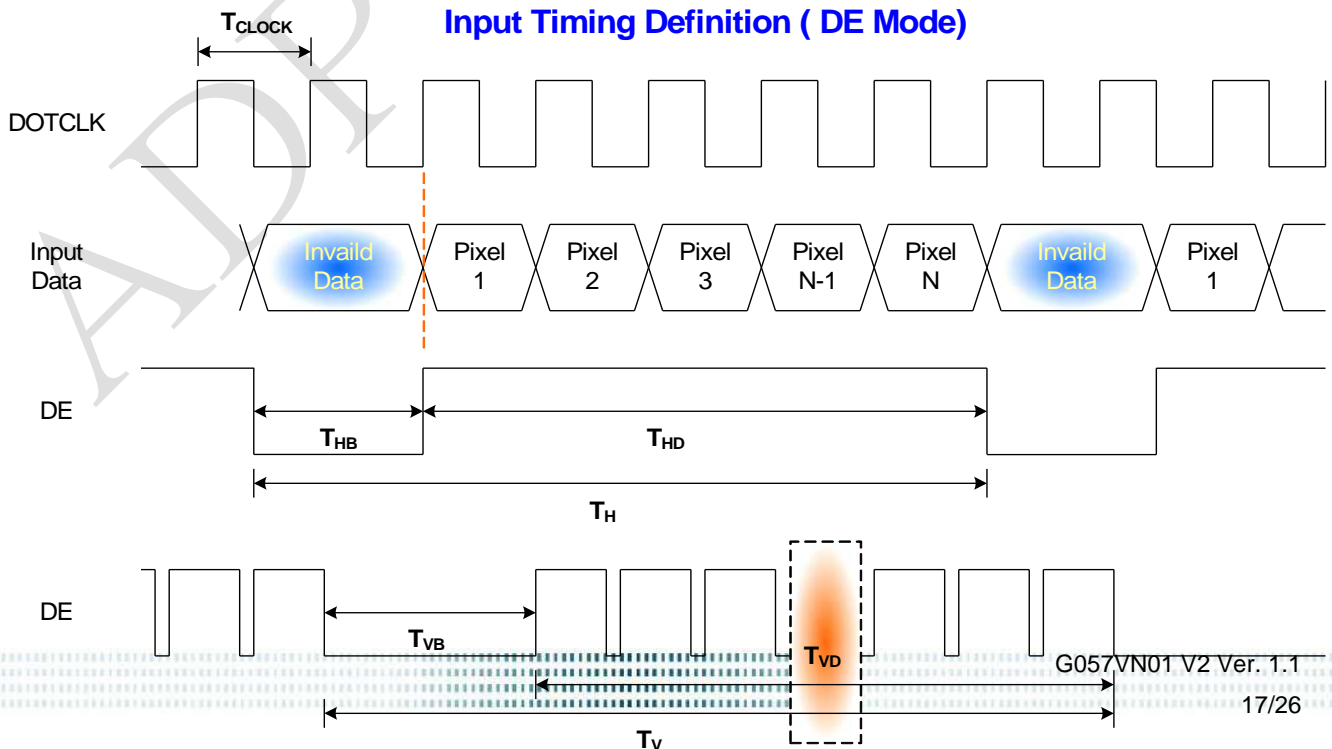

### 6.6 LED Backlight Unit Interface Signal Description

Pin #	Symbol	Pin Description
1	VLED	12V input
2	VLED	12V input
3	GND	Ground
4	GND	Ground
5	VLED_PWM	1~100% PWM diming
6	VLED_EN	0V-Off; 3.3~5V-On

Note 1: "NC" stands for "No Connection"

### 6.7 Power ON/OFF Sequence

VDD power, LCD interface signals and backlight on/off sequence are shown in the following chart. Signals from any system shall be Hi-Z state or low level when VDD is off.

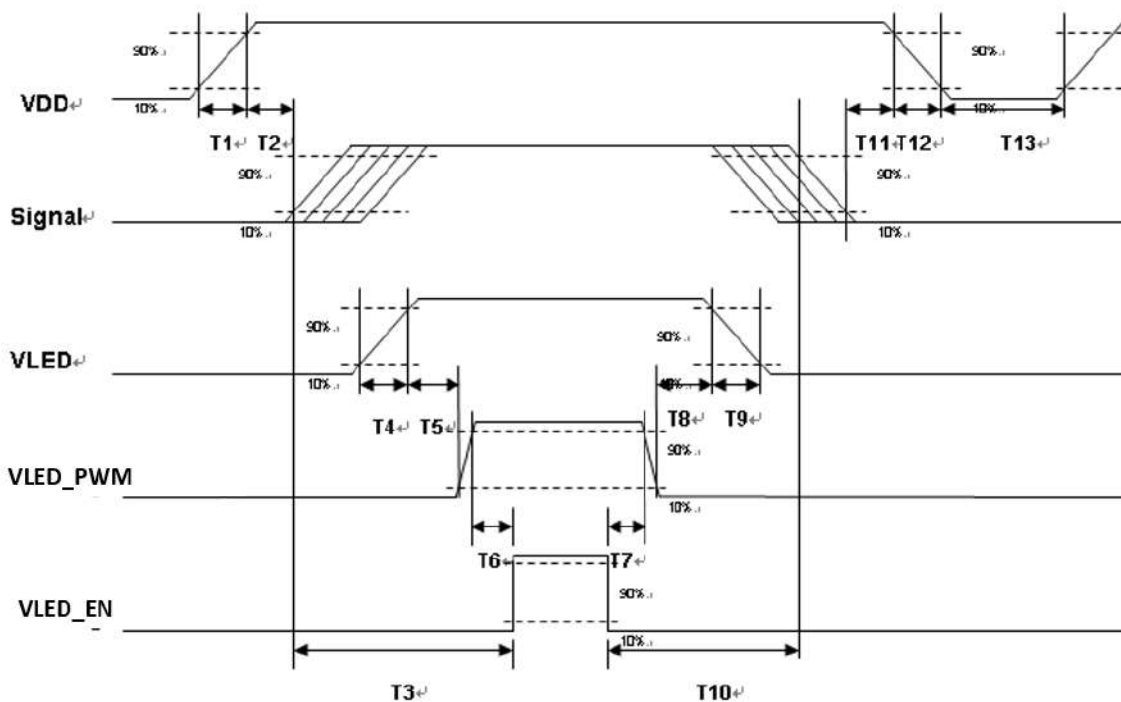

Power ON/OFF sequence timing

Parameter	Value	Units
-----------	-------	-------

	Min.	Typ.	Max.	
T1	0.5	--	10	[ms]
T2	30	--	50	[ms]
T3	220	--	--	[ms]
T4	0.5	--	10	[ms]
T5	10	--	--	[ms]
T6	10	--	--	[ms]
T7	0	--	--	[ms]
T8	10	--	--	[ms]
T9	--	--	10	[ms]
T10	110	--	--	[ms]
T11	0	16	50	[ms]
T12	100	--	250	[ms]
T13	1.5	--	--	[s]

ON/OFF sequence should be applied to avoid abnormal function in the display. Please make sure to turn off the power when you plug the cable into the input connector or pull the cable out of the connector.

ADP Confidential

## 7. Connector & Pin Assignment

### 7.1 TFT- LCD Signal (CN1): LCD Connector

Manufacturer	Starconn
Connector Model Number	089H33-000100-G2-R

Pin#	Symbol	Pin#	Symbol	Pin#	Symbol
1	GND	12	GND	23	B3
2	CLK	13	G0	24	B4
3	NC	14	G1	25	B5
4	NC	15	G2	26	GND
5	GND	16	G3	27	DE
6	R0	17	G4	28	VDD
7	R1	18	G5	29	VDD
8	R2	19	GND	30	R/L
9	R3	20	B0	31	U/D
10	R4	21	B1	32	NC
11	R5	22	B2	33	GND

### 7.2 LED Backlight Unit (CN2): Backlight Connector

Manufacturer	JST
Connector Model Number	SM06B-SRKS-G-TB
Mating Connector Model Number	JST SHR-06V-BKHF-B or compatible

Pin #	Symbol	Pin #	Symbol
1	V <sub>LED</sub>	4	GND
2	V <sub>LED</sub>	5	PWM DIM
3	GND	6	LED ON/OFF

### 7.3 LED Light Bar Input (CN3): Light Bar Connector

<b>Manufacturer</b>	STM
<b>Connector Model Number</b>	P24021P6
<b>Mating Connector Model Number</b>	SM06B-SHLS-TF or compatible

Pin #	Symbol	Pin Description	Cable color
1	AN1	Channel 1 LED anode	Red
2	AN2	Channel 2 LED anode	Red
3	AN3	Channel 3 LED anode	Red
4	CA1	Channel 1 LED cathode	White
5	CA2	Channel 2 LED cathode	Blue
6	CA3	Channel 3 LED cathode	Black

ADP Confidential

**7.4 PIN 1 definition of CN1 and CN2**

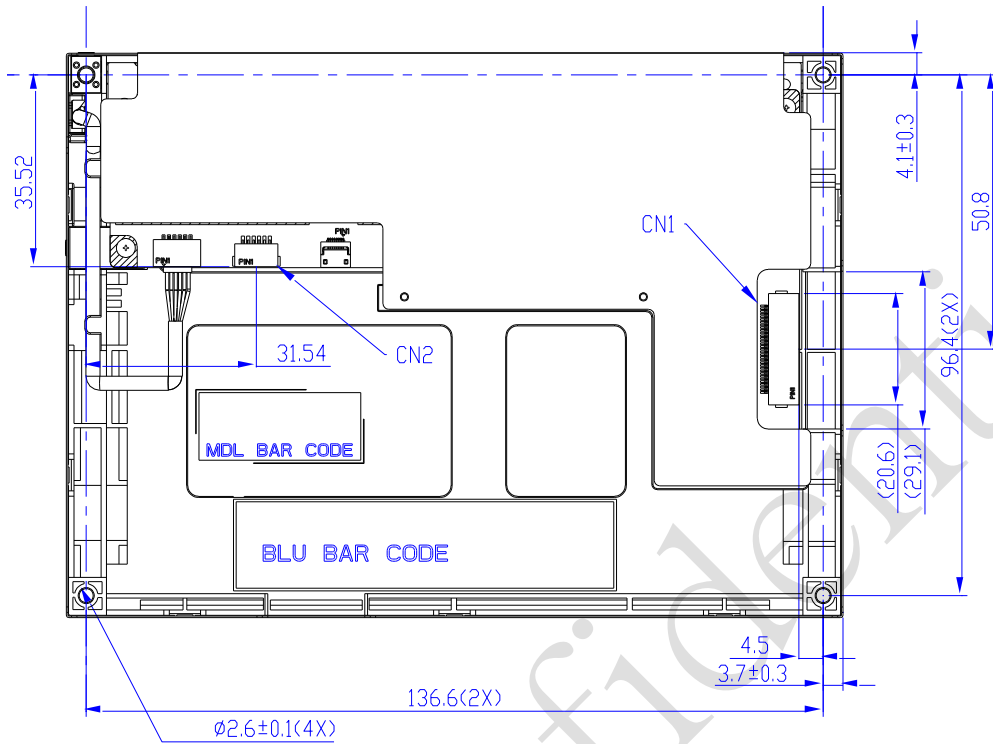

( Rear side of TFT-LCD )

**7.5 PIN 1 definition of CN3**

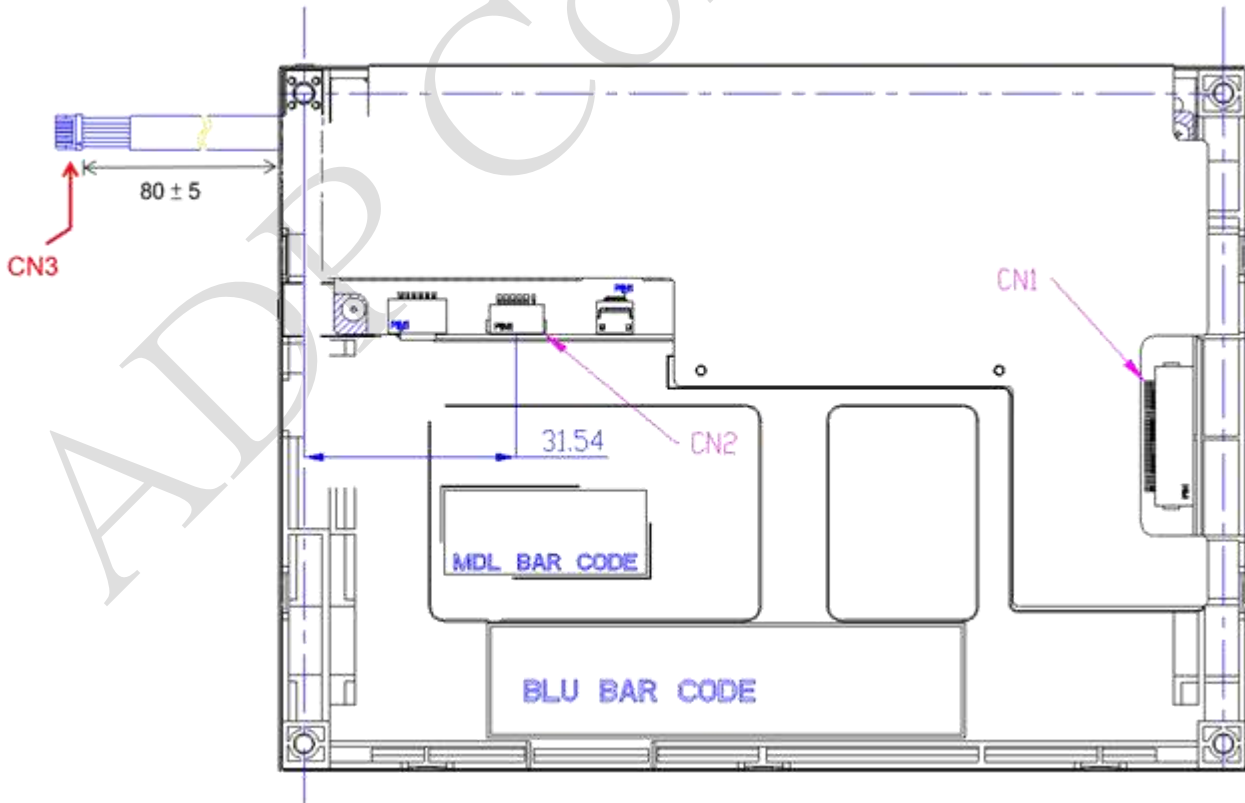

## 8. Reliability Test Criteria

Items	Required Condition	Remark
Temperature Humidity Bias	40°C/90%,300Hr	Note 2
High Temperature Operation	85°C,300Hr	Note 2
Low Temperature Operation	-30°C,300Hr	Note 2
High Temperature Storage	85°C,300 hours	Note 2
Low Temperature Storage	-30°C ,300 hours	Note 2
Thermal Shock Test	-20°C/30 min ,60°C/30 min ,100cycles	Note 2
Hot Start Test	85°C/1 Hr (min.), power on/off per 5 minutes, repeat 5 times	Note 2
Cold Start Test	-30°C/1 Hr (min.), power on/off per 5 minutes, repeat 5 times	Note 2
Shock Test (Non-Operating)	50G,20ms,Half-sine wave, (±X, ±Y, ±Z)	Note 2
Vibration Test (Non-Operating)	1.5G, 10~200~10Hz, Sine wave, 30mins/axis, 3 direction (X, Y, Z)	Note 2
ESD	Contact Discharge: ±8KV, 150pF(330Ω) 1sec, 8 points, 25 times/point Air Discharge: ±15KV, 150pF(330Ω) 1sec, 8 points, 25 times/point	Note 1,2
Attitude Test	Operating: 14,000 ft, Ramp: 2000 ft/min, 8hrs Non-operating: 40,000 ft, Ramp: 2000 ft/min, 24hrs	Note 2

Note1: According to EN61000-4-2 ESD class B criteria, some performance degradation is allowed.

TFT-LCD module is self-recoverable, no data lost and no hardware failures after test.

Note2:

- Water condensation is not allowed for each test items.
- Each test is done by new TFT-LCD module. Don't use the same TFT-LCD module repeatedly for reliability test.
- The reliability test is performed only to examine the TFT-LCD module capability.
- To inspect TFT-LCD module after reliability test, please store it at room temperature and room humidity for 24 hours at least in advance.

### 9. Mechanical Characteristics

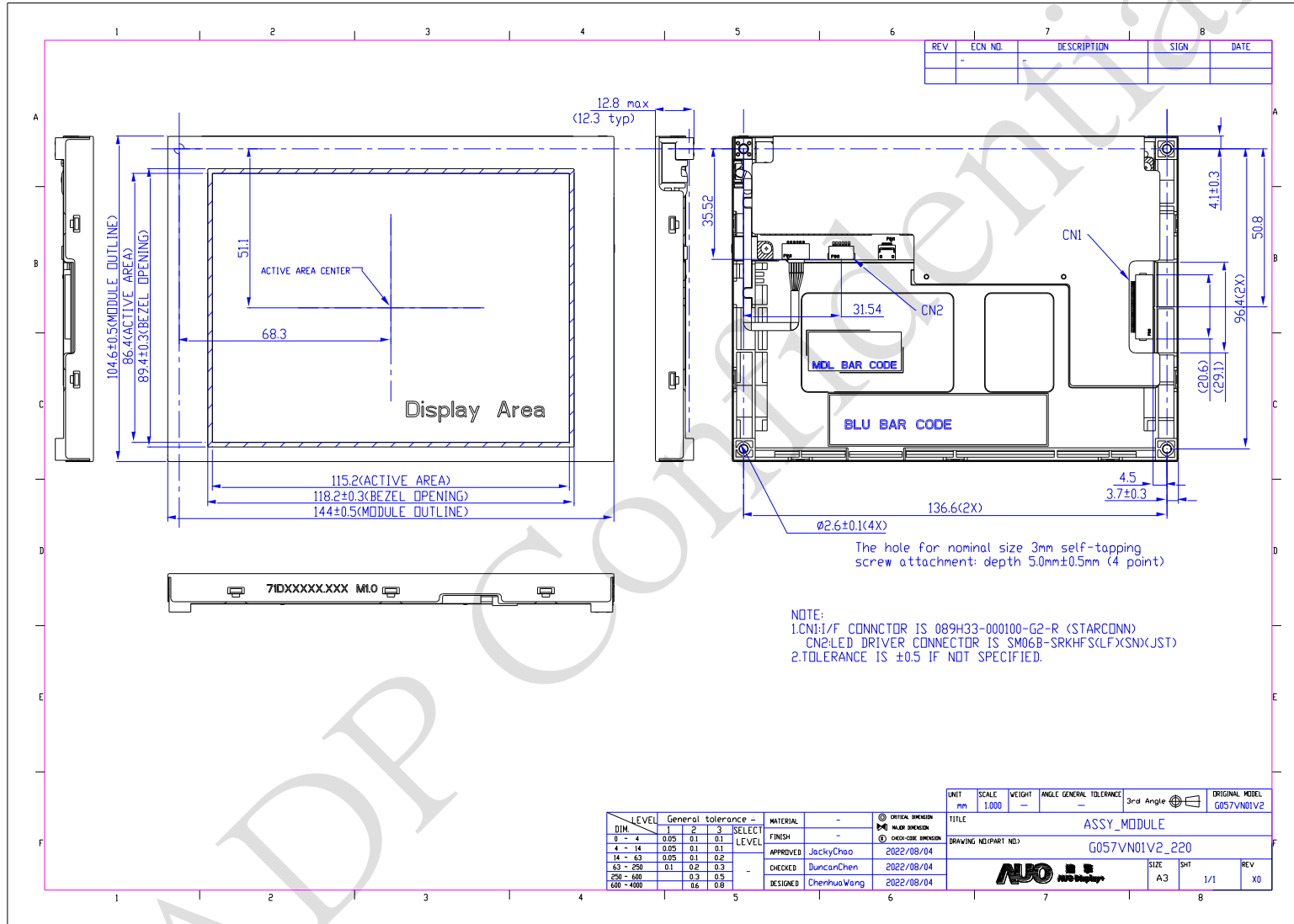

Note : Please evaluate the tightening torque according to customer's application.



## 10. Label and Packaging

### 10.1 Shipping Label (on the rear side of TFT-LCD display)



### 10.2 Carton Package

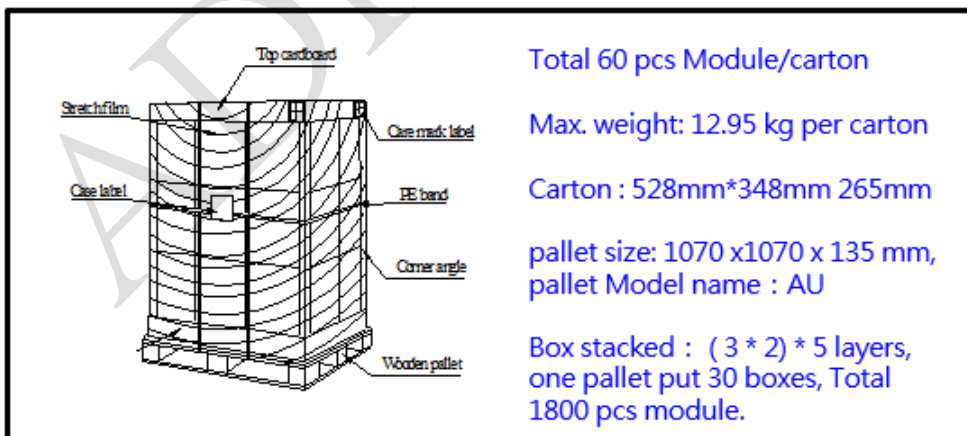
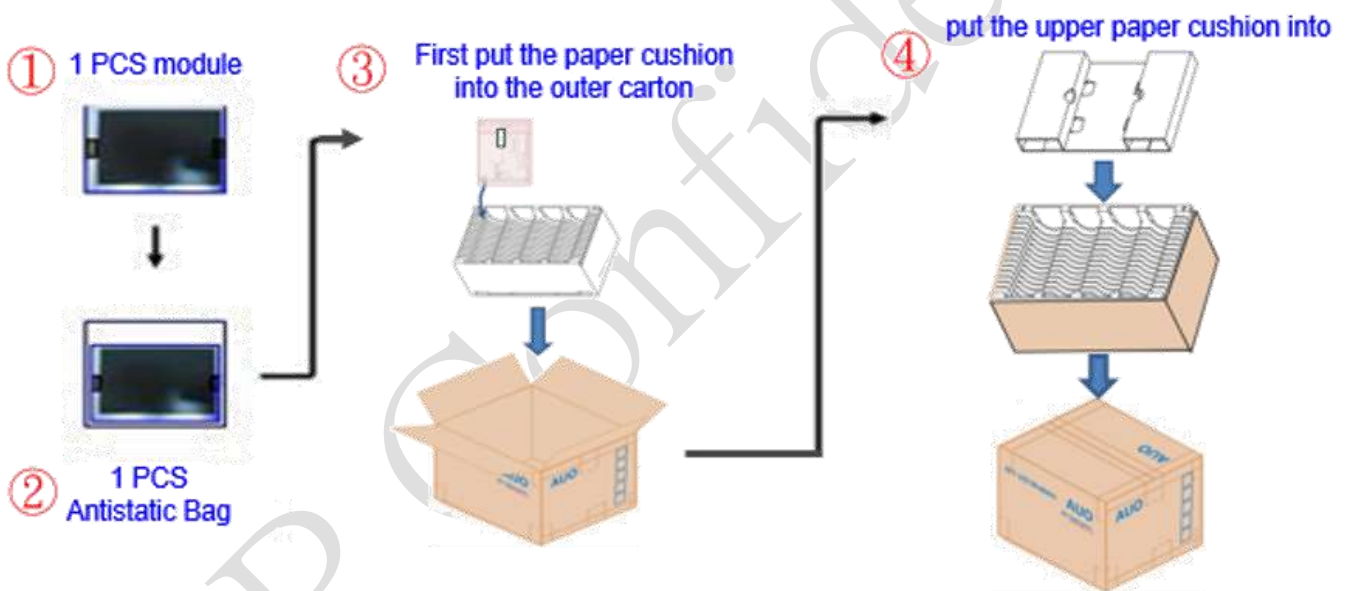

## 11 Safety

### 11.1 Keen Edge Requirements

There will be no keen edges or corners on the display assembly that could cause injury.

### 11.2 Materials

#### 11.2.1 Toxicity

There will be no carcinogenic materials used anywhere in the TFT-LCD module. If toxic materials are used, they will be reviewed and approved by the responsible AUO toxicologist.

#### 11.2.2 Flammability

All components including electrical components that do not meet the flammability grade UL94-V1 in the TFT-LCD Module will complete the flammability rating exception approval process.

The printed circuit board will be made from material rated 94-V1 or better. The actual UL flammability rating will be printed on the printed circuit board.

### 11.3 Capacitors

If any polarized capacitors are used in the TFT-LCD module, provisions will be made to keep them from being inserted backwards.

### 11.4 National Test Lab Requirement

The TFT-LCD Module will satisfy all requirements for compliance to UL 60950 (U.S.A. Information Technology Equipment).