



AUO Display+

Product Specification

G190EAN01.6

- Preliminary Specification
- Final Specification

Module	19 Inch Color TFT-LCD
Model Name	G190EAN01.6

Customer	Date
Checked & Approved by	Date

Approved by	Date
Buffy Chen	2023/05/31
Prepared by	Date
Isaac TY Huang	2023/05/31
General Display Business Unit / AUO Display Plus Corporation	

Contents

1. Operating Precautions4

2. General Description.....5

 2.1 Display Characteristics..... 5

 2.2 Optical Characteristics 6

3. Functional Block Diagram.....9

4. Absolute Maximum Ratings 10

 4.1 Absolute Ratings of TFT LCD Module..... 10

 4.2 Absolute Ratings of Environment..... 10

5. Electrical Characteristics 11

 5.1 TFT LCD Module 11

 5.2 Backlight Unit 13

6. Signal Characteristic 15

 6.1 Pixel Format Image 15

 6.2 Scanning Direction 15

 6.3 Signal Description 16

 6.4 The Input Data Format..... 18

 6.5 Interface Timing 19

 6.6 Power ON/OFF Sequence 20

7. Reliability Test Criteria 21

8. Mechanical Characteristics..... 22

 8.1 LCM Outline Dimension 22

9. Label and Packaging 24

 9.1 Shipping Label (on the rear side of TFT-LCD display) 24

 9.2 Carton Package 24

Record of Revision

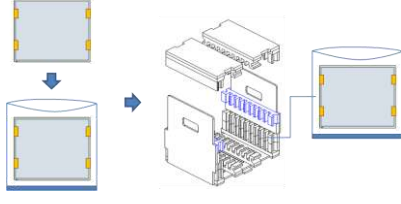
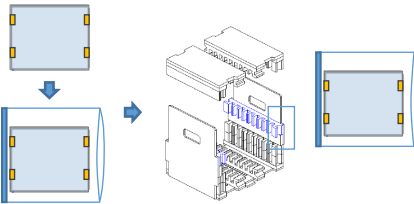
Version	Date (yyyy/m/d)	Page	Old description	New Description																																																																																																											
V0	2020/ 5/ 13	All	First draft specification																																																																																																												
V1	2021/ 11/ 08	P14	<table border="1"> <thead> <tr> <th>Symbol</th> <th>Parameter</th> <th>Min</th> <th>Typ</th> <th>Max</th> <th>Units</th> <th>Remark</th> </tr> </thead> <tbody> <tr> <td>VLED (Note 1)</td> <td>LED Power Supply</td> <td>10.8</td> <td>12.0</td> <td>13.2</td> <td>[Volt]</td> <td rowspan="10">Define as Connector Interface (Ta=25°C)</td> </tr> <tr> <td rowspan="2">VLED_EN</td> <td>LED Enable Input - High Level</td> <td>2.5</td> <td>---</td> <td>5.5</td> <td>[Volt]</td> </tr> <tr> <td>LED Enable Input - Low Level</td> <td>---</td> <td>---</td> <td>0.7</td> <td>[Volt]</td> </tr> <tr> <td rowspan="2">VPWM_EN</td> <td>PWM Logic Input - High Level</td> <td>2.5</td> <td>---</td> <td>5.5</td> <td>[Volt]</td> </tr> <tr> <td>PWM Logic Input - Low Level</td> <td>---</td> <td>---</td> <td>0.7</td> <td>[Volt]</td> </tr> <tr> <td rowspan="2">FPWM</td> <td>PWM Input Frequency *1</td> <td>200</td> <td>---</td> <td>20K</td> <td>Hz</td> </tr> <tr> <td>PWM Duty Ratio</td> <td>10</td> <td>---</td> <td>100</td> <td>%</td> </tr> </tbody> </table> <p>Note1: Measured on panel VLED.</p>	Symbol	Parameter	Min	Typ	Max	Units	Remark	VLED (Note 1)	LED Power Supply	10.8	12.0	13.2	[Volt]	Define as Connector Interface (Ta=25°C)	VLED_EN	LED Enable Input - High Level	2.5	---	5.5	[Volt]	LED Enable Input - Low Level	---	---	0.7	[Volt]	VPWM_EN	PWM Logic Input - High Level	2.5	---	5.5	[Volt]	PWM Logic Input - Low Level	---	---	0.7	[Volt]	FPWM	PWM Input Frequency *1	200	---	20K	Hz	PWM Duty Ratio	10	---	100	%	<table border="1"> <thead> <tr> <th>Symbol</th> <th>Parameter</th> <th>Min</th> <th>Typ</th> <th>Max</th> <th>Units</th> <th>Remark</th> </tr> </thead> <tbody> <tr> <td>VLED (Note 1)</td> <td>LED Power Supply</td> <td>10.8</td> <td>12.0</td> <td>13.2</td> <td>[Volt]</td> <td rowspan="10">Define as Connector Interface (Ta=25°C)</td> </tr> <tr> <td rowspan="2">VLED_EN</td> <td>LED Enable Input - High Level</td> <td>2.5</td> <td>---</td> <td>5.5</td> <td>[Volt]</td> </tr> <tr> <td>LED Enable Input - Low Level</td> <td>---</td> <td>---</td> <td>0.7</td> <td>[Volt]</td> </tr> <tr> <td rowspan="2">VPWM_EN</td> <td>PWM Logic Input - High Level</td> <td>2.5</td> <td>---</td> <td>5.5</td> <td>[Volt]</td> </tr> <tr> <td>PWM Logic Input - Low Level</td> <td>---</td> <td>---</td> <td>0.7</td> <td>[Volt]</td> </tr> <tr> <td rowspan="2">FPWM</td> <td>PWM Input Frequency *1</td> <td>200</td> <td>---</td> <td>20K</td> <td>Hz</td> </tr> <tr> <td>PWM Duty Ratio</td> <td>10</td> <td>---</td> <td>100</td> <td>%</td> </tr> <tr> <td rowspan="2">Duty</td> <td>Dimming Duty 200 Hz~5K Hz</td> <td>5</td> <td>---</td> <td>100</td> <td>%</td> <td>-</td> </tr> <tr> <td>Dimming Duty 5K Hz~20K Hz</td> <td>15</td> <td>---</td> <td>100</td> <td>%</td> <td>-</td> </tr> </tbody> </table> <p>Note1: Measured on panel VLED.</p>	Symbol	Parameter	Min	Typ	Max	Units	Remark	VLED (Note 1)	LED Power Supply	10.8	12.0	13.2	[Volt]	Define as Connector Interface (Ta=25°C)	VLED_EN	LED Enable Input - High Level	2.5	---	5.5	[Volt]	LED Enable Input - Low Level	---	---	0.7	[Volt]	VPWM_EN	PWM Logic Input - High Level	2.5	---	5.5	[Volt]	PWM Logic Input - Low Level	---	---	0.7	[Volt]	FPWM	PWM Input Frequency *1	200	---	20K	Hz	PWM Duty Ratio	10	---	100	%	Duty	Dimming Duty 200 Hz~5K Hz	5	---	100	%	-	Dimming Duty 5K Hz~20K Hz	15	---	100	%	-
Symbol	Parameter	Min	Typ	Max	Units	Remark																																																																																																									
VLED (Note 1)	LED Power Supply	10.8	12.0	13.2	[Volt]	Define as Connector Interface (Ta=25°C)																																																																																																									
VLED_EN	LED Enable Input - High Level	2.5	---	5.5	[Volt]																																																																																																										
	LED Enable Input - Low Level	---	---	0.7	[Volt]																																																																																																										
VPWM_EN	PWM Logic Input - High Level	2.5	---	5.5	[Volt]																																																																																																										
	PWM Logic Input - Low Level	---	---	0.7	[Volt]																																																																																																										
FPWM	PWM Input Frequency *1	200	---	20K	Hz																																																																																																										
	PWM Duty Ratio	10	---	100	%																																																																																																										
Symbol	Parameter	Min	Typ	Max	Units		Remark																																																																																																								
VLED (Note 1)	LED Power Supply	10.8	12.0	13.2	[Volt]		Define as Connector Interface (Ta=25°C)																																																																																																								
VLED_EN	LED Enable Input - High Level	2.5	---	5.5	[Volt]																																																																																																										
	LED Enable Input - Low Level	---	---	0.7	[Volt]																																																																																																										
VPWM_EN	PWM Logic Input - High Level	2.5	---	5.5	[Volt]																																																																																																										
	PWM Logic Input - Low Level	---	---	0.7	[Volt]																																																																																																										
FPWM	PWM Input Frequency *1	200	---	20K	Hz																																																																																																										
	PWM Duty Ratio	10	---	100	%																																																																																																										
Duty	Dimming Duty 200 Hz~5K Hz	5	---	100	%	-																																																																																																									
	Dimming Duty 5K Hz~20K Hz	15	---	100	%	-																																																																																																									
V2	2023/ 05/ 31	P24																																																																																																													

AUO Display+

1. Operating Precautions

- 1) Since front polarizer is easily damaged, please be cautious and not to scratch it.
- 2) Be sure to turn off power supply when inserting or disconnecting from input connector.
- 3) Wipe off water drop immediately. Long contact with water may cause discoloration or spots.
- 4) When the panel surface is soiled, wipe it with absorbent cotton or soft cloth.
- 5) Since the panel is made of glass, it may be broken or cracked if dropped or bumped on hard surface.
- 6) To avoid ESD (Electro Static Discharge) damage, be sure to ground yourself before handling TFT-LCD Module.
- 7) Do not open nor modify the module assembly.
- 8) Do not press the reflector sheet at the back of the module to any direction.
- 9) In case if a module has to be put back into the packing container slot after it was taken out from the container, do not press the center of the LED light bar edge. Instead, press at the far ends of the LED light bar edge softly. Otherwise the TFT Module may be damaged.
- 10) At the insertion or removal of the Signal Interface Connector, be sure not to rotate nor tilt the Interface Connector of the TFT Module.
- 11) TFT-LCD Module is not allowed to be twisted & bent even force is added on module in a very short time. Please design your display product well to avoid external force applying to module by end-user directly.
- 12) Small amount of materials having no flammability grade is used in the LCD module. The LCD module should be supplied by power complied with requirements of Limited Power Source (IEC60950 or UL1950), or be applied exemption.
- 13) Severe temperature condition may result in different luminance, response time and lamp ignition voltage.
- 14) Continuous operating TFT-LCD display under low temperature environment may accelerate lamp exhaustion and reduce luminance dramatically.
- 15) The data on this specification sheet is applicable when LCD module is placed in landscape position.
- 16) Continuous displaying fixed pattern may induce image sticking. It's recommended to use screen saver or shuffle content periodically if fixed pattern is displayed on the screen.

2. General Description

This specification applies to the Color Active Matrix Liquid Crystal Display G190EAN01.6 composed of a TFT-LCD display, a driver and power supply circuit, and a LED backlight system. The screen format is intended to support the SXGA (1280(H) x 1024(V)) screen and 16.7M colors. All input signals are 2-channel LVDS interface compatible. LED driving board for backlight unit is included in G190EAN01.6.

2.1 Display Characteristics

The following items are characteristics summary on the table under 25 °C condition:

Items	Unit	Specifications
Screen Diagonal	[inch]	19.0"
Active Area	[mm]	376.32 (H) x 301.06 (V)
Resolution		1280(x3) x 1024
Pixel Pitch	[mm]	0.294 (per one triad) x 0.294
Pixel Arrangement		R.G.B. Vertical Stripe
Display Mode		Normally Black, AHVA
Nominal Input Voltage VDD	[Volt]	+5.0 V
Power Consumption	[Watt]	Logic: max. 4W@ white pattern BL power: max. 37.5W
Weight	[Grams]	1700 +/- 150g
Physical Size	[mm]	396 (H) x 324 (V) x 15.3 (D) (Typ)
Electrical Interface		LVDS
Surface Treatment		Anti-Glare treatment
Support Color		16.7M colors (8bit)
Temperature Range		
Operating	[°C]	0 to +50
Storage (Non-Operating)	[°C]	-20 to +60
RoHS Compliance		Yes

2.2 Optical Characteristics

The optical characteristics are measured under stable conditions at 25 °C (Room Temperature):

Item	Unit	Conditions		Min.	Typ.	Max.	Note
White Luminance	cd/m ²	Center point		800	1000	---	1
Uniformity	%	9 points		75	---	---	2,3
Uniformity	%	5 points		80	---	---	4
Contrast Ratio	--			800	1000		5
Response Time	msec	Rising		-	13	18	6
		Falling		-	12	17	
		Rising + Falling		-	25	35	
Viewing Angle	degree	Horizontal CR >= 10	(Right)	85	89	---	7
			(Left)	85	89		
		Vertical CR >= 10	(Upper)	85	89		
			(Lower)	85	89		
Color / Chromaticity Coordinates (CIE 1931)	--	Red x		0.621	0.651	0.681	
		Red y		0.313	0.343	0.373	
		Green x		0.272	0.302	0.332	
		Green y		0.581	0.611	0.641	
		Blue x		0.125	0.155	0.185	
		Blue y		0.045	0.075	0.105	
		White x		0.269	0.299	0.329	
		White y		0.285	0.315	0.345	
Color Gamut	%			---	72%	---	

Note 1: Measurement method

Equipment Pattern Generator, Power Supply, Digital Voltmeter, Luminance meter (SR_3 or equivalent)

Aperture 1° with 50cm viewing distance

Test Point Center

Environment < 1 lux

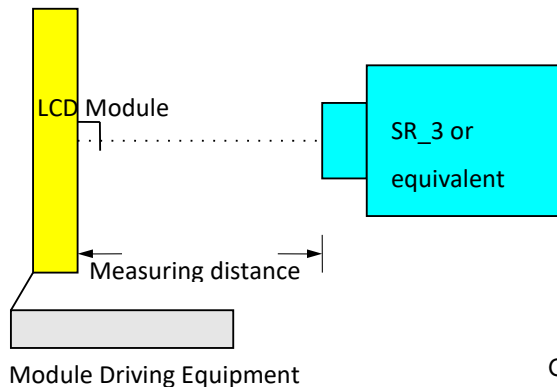

AUO Display+

Note 2: Definition of 9 points position

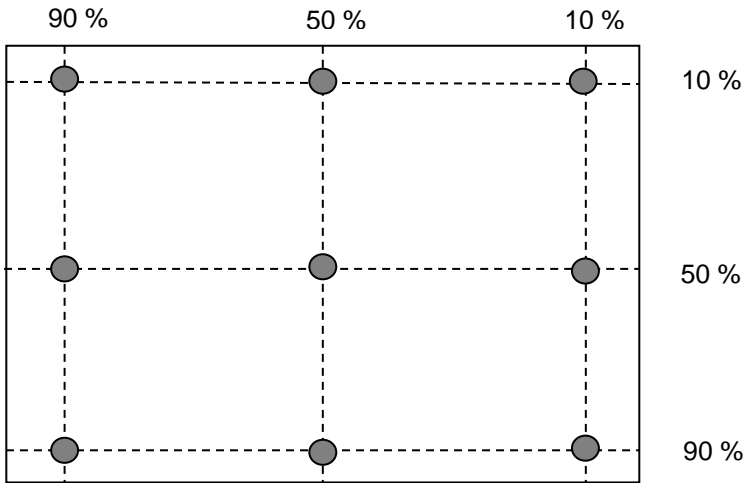

Note 3: The luminance uniformity of 9 points is defined by dividing the minimum luminance values by the maximum test point luminance

$$\delta_{w9} = \frac{\text{Minimum Brightness of nine points}}{\text{Maximum Brightness of nine points}}$$

Note 4: Definition of 5 points position

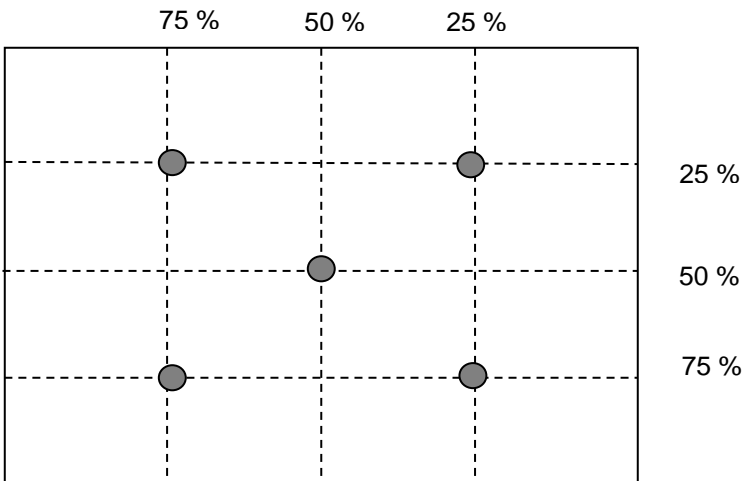

The luminance uniformity of 5 points is defined by dividing the minimum luminance values by the maximum test point luminance of L26 and L204 with PWM 59% duty.

$$\delta_{w5} = \frac{\text{Minimum Brightness of five points}}{\text{Maximum Brightness of five points}}$$

Note 5: Definition of contrast ratio (CR):

$$\text{Contrast ratio (CR)} = \frac{\text{Brightness on the "White" state}}{\text{Brightness on the "Black" state}}$$

Note 6: Definition of response time:

The output signals of photo detector are measured when the input signals are changed from "White" to "Black" (falling time) and from "Black" to "White" (rising time), respectively. The response time interval is between 10% and 90% of amplitudes. Please refer to the figure as below.

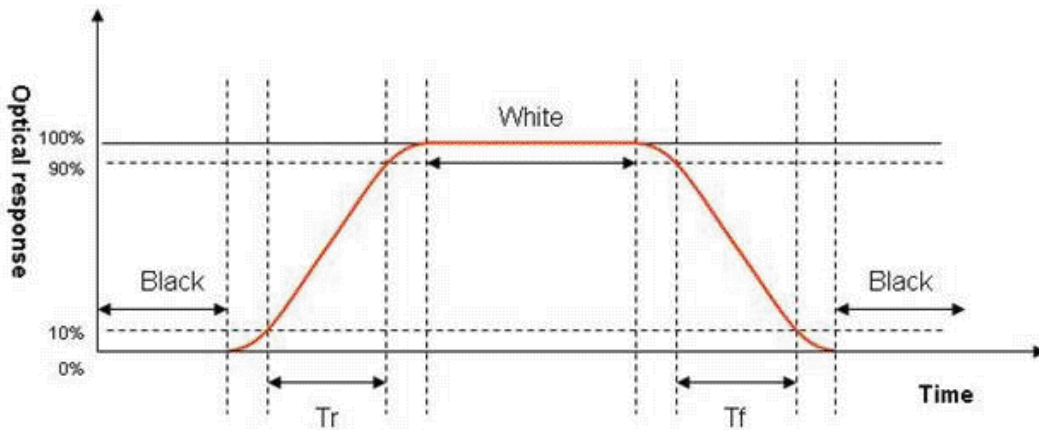

Note 7: Definition of viewing angle

Viewing angle is the measurement of contrast ratio ≥ 10 , at the screen center, over a 180° horizontal and 180° vertical range (off-normal viewing angles). The 180° viewing angle range is broken down as below: 90° (θ) horizontal left and right, and 90° (Φ) vertical high (up) and low (down). The measurement direction is typically perpendicular to the display surface with the screen rotated to its center to develop the desired measurement viewing angle.

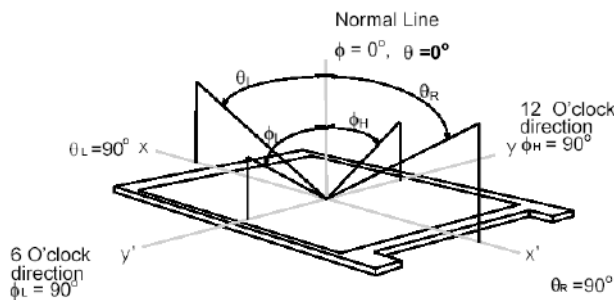

AUO Display+

3. Functional Block Diagram

The following diagram shows the functional block of the 19 inch color TFT/LCD module:

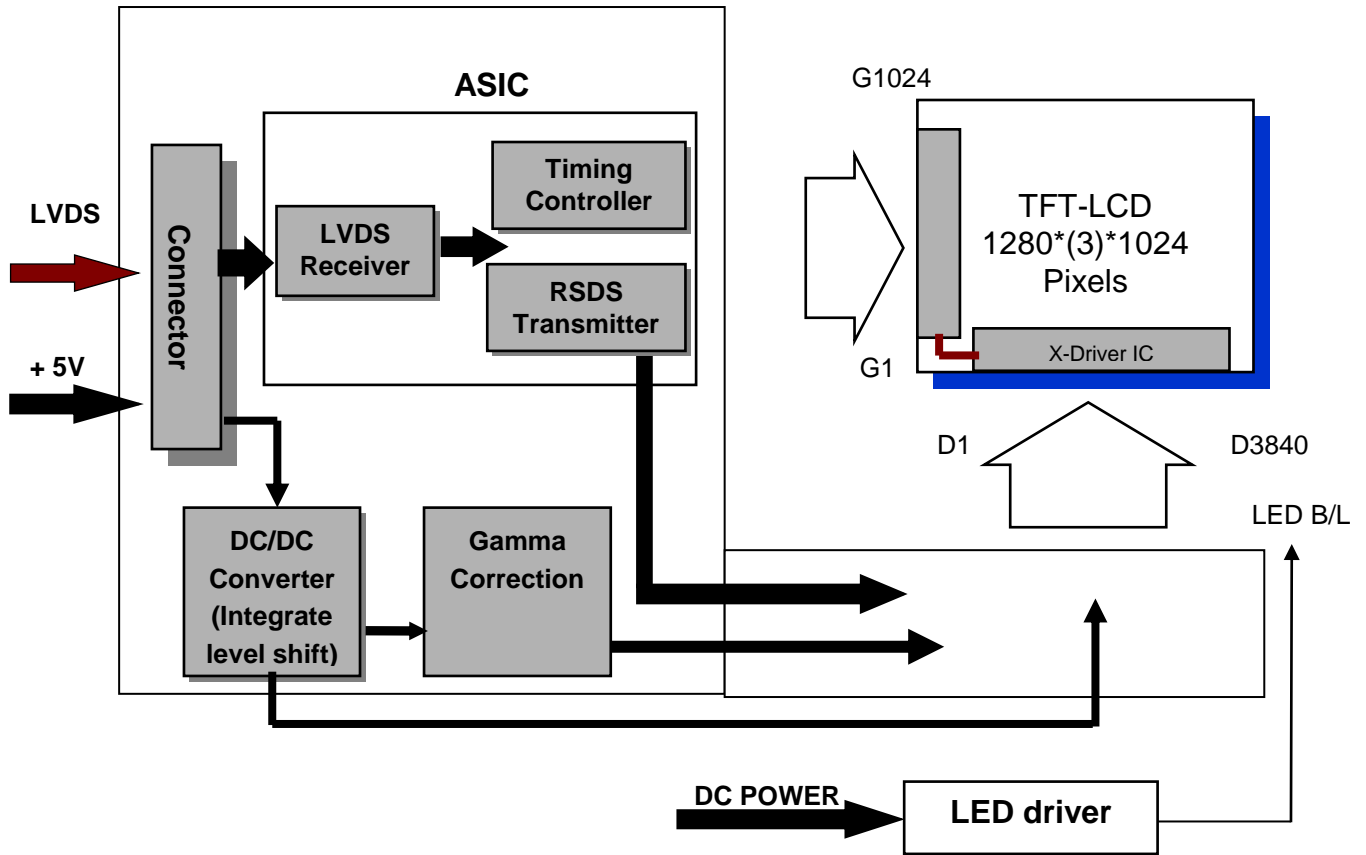

I/F PCB Interface:

FI-XB30SSL-HF15 / MSBKT2407P30HB

Mating Type:

FI-X30HL (Locked Type)

FI-X30H (Unlocked Type)

AUO Display+

4. Absolute Maximum Ratings

4.1 Absolute Ratings of TFT LCD Module

Item	Symbol	Min	Max	Unit
Logic/LCD drive Voltage	Vin	-0.3	+5.5	[Volt]

4.2 Absolute Ratings of Environment

Item	Symbol	Min	Max	Unit
Operating Temperature	TOP	0	+50	[°C]
Operation Humidity	HOP	5	90	[%RH]
Storage Temperature	TST	-20	+60	[°C]
Storage Humidity	HST	5	90	[%RH]

Note: Maximum Wet-Bulb should be 39 °C and no condensation.

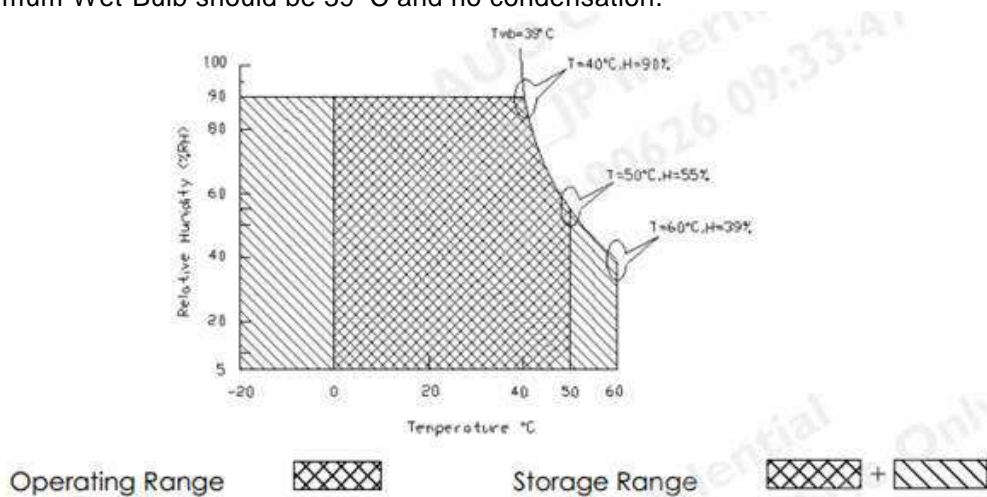

AUO Display+

5. Electrical Characteristics

5.1 TFT LCD Module

5.1.1 Power Specification

Input power specifications are shown as follows;

Symbol	Parameter	Min	Typ	Max	Units	Remark
VDD	Logic/LCD Drive Voltage	4.5	5.0	5.5	[Volt]	±10%
IDD	VDD Current	-	0.67	0.80	[A]	White Pattern (VDD=5V, at 60Hz)
Irush	LCD Inrush Current	-	2.7	3.4	[A]	Note 1
PDD	VDD Power	-	3.35	4.0	[Watt]	White Pattern (VDD=5V, at 60Hz)
VDDrp	Allowable Logic/LCD Drive Ripple Voltage	-	-	300	[mV] p-p	With panel loading

Note 1: Measurement condition:

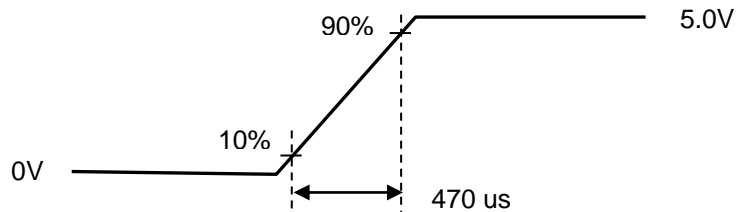
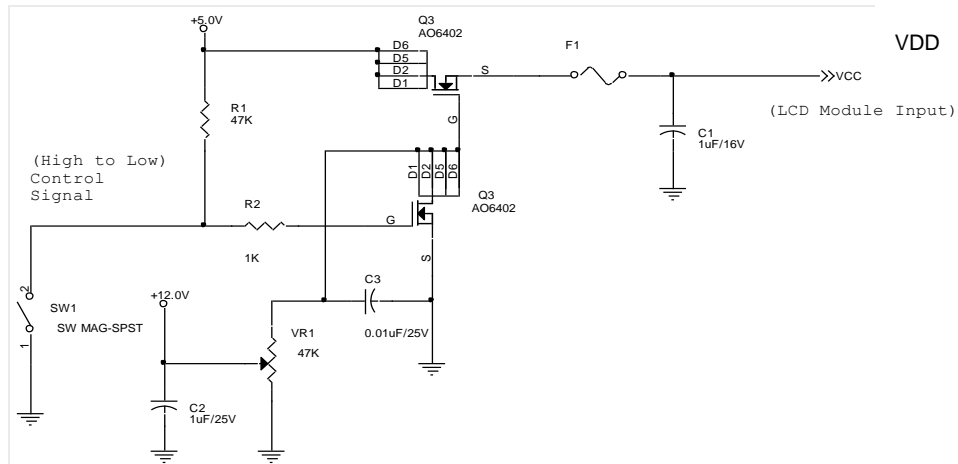

VDD rising time

Symbol	Item	Min.	Typ.	Max.	Unit	Remark
V _{TH}	Differential Input High Threshold	-	-	+100	[mV]	V _{CM} =1.2V
V _{TL}	Differential Input Low Threshold	-100	-	-	[mV]	V _{CM} =1.2V
VID	Input Differential Voltage	100	400	600	[mV]	
V _{ICM}	Differential Input Common Mode Voltage	+1.0	+1.2	+1.5	[V]	V _{TH} /V _{TL} =±100mV

5.1.2 LVDS DC Signal Electrical Characteristics

Input signals shall be low or Hi-Z state when VDD is off.

Note: LVDS Signal Waveform.

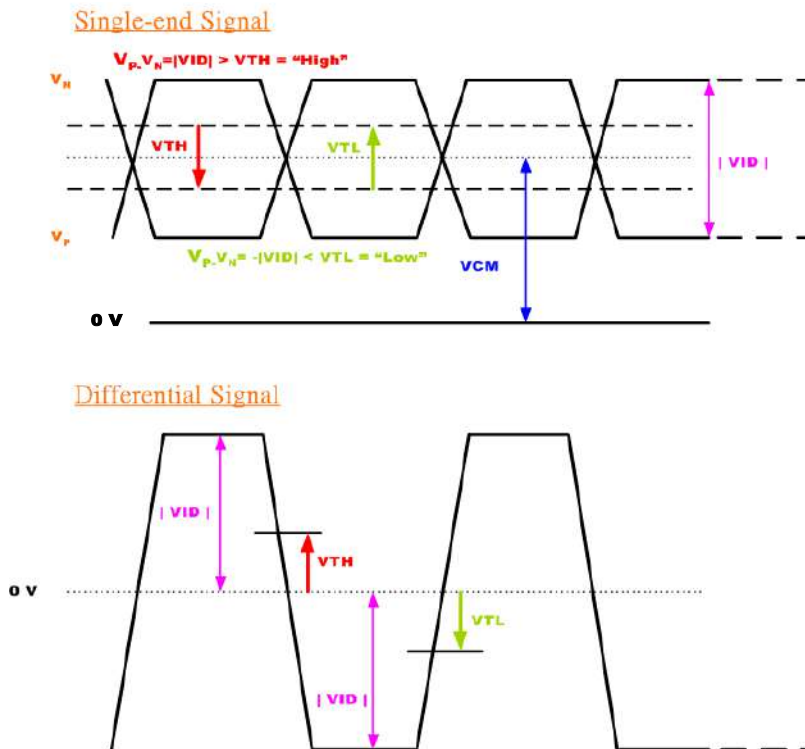

5.2 Backlight Unit

5.2.1 LED Backlight Unit: Driver Connector

Connector Name / Designation	Lamp Connector
Manufacturer	STM
Connector Model Number	MS24019RHD
Mating Model Number	P24019

Pin #	Symbol	Pin Description
1	+12V	Power +12V
2	+12V	Power +12V
3	+12V	Power +12V
4	NC	NC
5	GND	GND
6	GND	GND
7	GND	GND
8	EN	Enable(0V:disable, 5V:Enable)
9	Dimming	PWM; duty 10%~ 100%

AUO Display+

5.2.2 Parameter guideline for LED

Following characteristics are measured under a stable condition using an inverter at 25°C (Room Temperature):

LED characteristics

Symbol	Parameter	Min	Typ	Max	Units	Condition
PLED	Backlight Power Consumption	-	34.2	37.5	[Watt]	LED only
LTLED	LED Life-Time	50,000	--	--	Hour	LED only

Note 1: Calculator value for reference $P_{LED} = V_F$ (Normal Distribution) * I_F (Normal Distribution) / Efficiency

Note 2: The LED life-time define as the estimated time to 50% degradation of initial luminous.

Backlight input signal characteristics

Symbol	Parameter	Min	Typ	Max	Units	Remark
VLED (Note 1)	LED Power Supply	10.8	12.0	13.2	[Volt]	Define as Connector Interface (Ta=25°C)
VLED_EN	LED Enable Input High Level	2.5	--	5.5	[Volt]	
	LED Enable Input Low Level	--	--	0.7	[Volt]	
VPWM_EN	PWM Logic Input High Level	2.5	--	5.5	[Volt]	
	PWM Logic Input Low Level	--	--	0.7	[Volt]	
FPWM	PWM Input Frequency *1	200	--	20K	Hz	
Duty	Dimming Duty 200 Hz~5K Hz	5	--	100	%	
	Dimming Duty 5K Hz~20K Hz	15	--	100	%	

Note1: Measured on panel VLED

AUO Display+

6. Signal Characteristic

6.1 Pixel Format Image

Following figure shows the relationship between input signal and LCD pixel format.

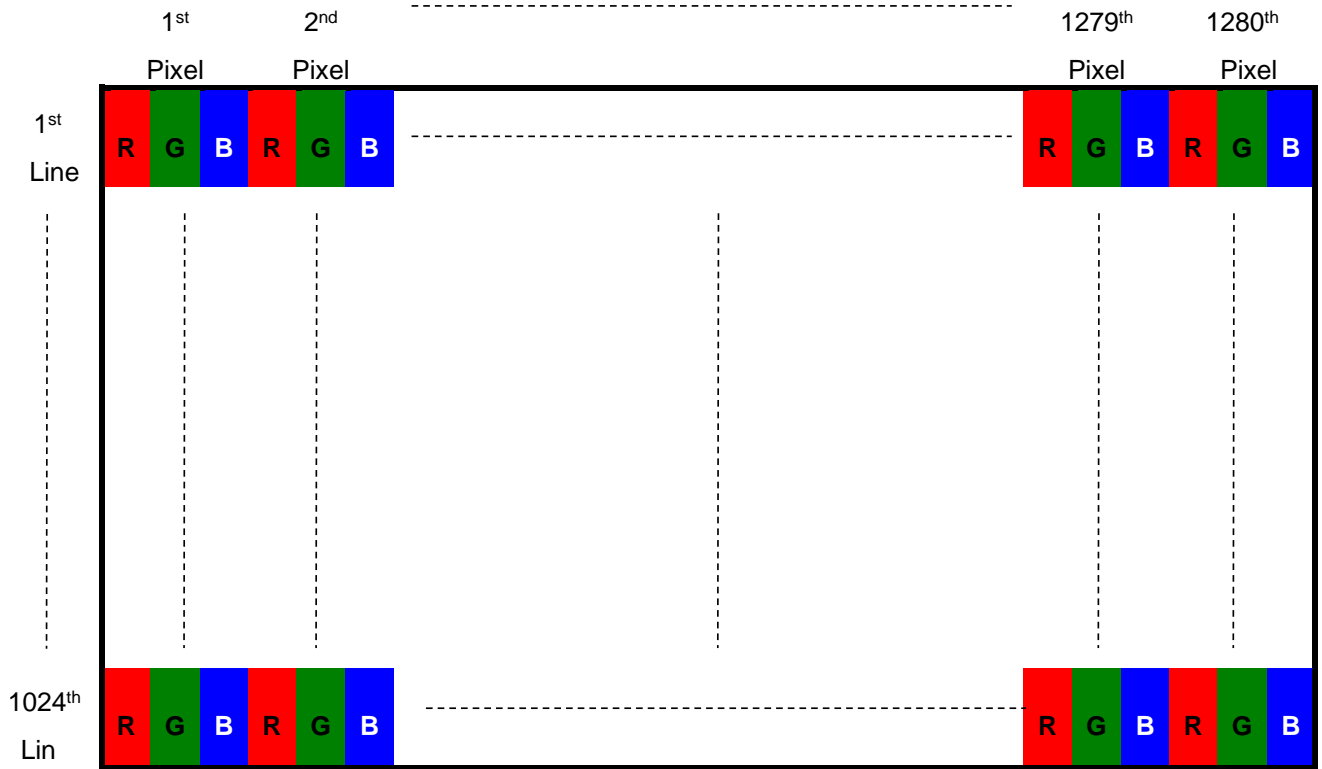

6.2 Scanning Direction

The following figures show the image seen from the front view. The arrow indicates the direction of scan.



6.3 Signal Description

The module uses a LVDS receiver embedded in AUO's ASIC. LVDS is a differential signal technology for LCD interface and a high-speed data transfer device.

6.3.1 TFT LCD Module: LVDS Connector

Connector Name / Designation	Signal Connector
Manufacturer	JAE / STM
Connector Model Number	FI-XB30SSLA-HF15 / MSBKT2407P30HB
Adaptable Plug	FI-X30HL FI-X30H (Unlocked Type)

Pin#	Signal Name	Pin#	Signal Name
1	RxOIN0-	2	RxOIN0+
3	RxOIN1-	4	RxOIN1+
5	RxOIN2-	6	RxOIN2+
7	VSS	8	RxOCLKIN-
9	RxOCLKIN+	10	RxOIN3-
11	RxOIN3+	12	RxEIN0-
13	RxEIN0+	14	VSS
15	RxEIN1-	16	RxEIN1+
17	VSS	18	RxEIN2-
19	RxEIN2+	20	RxECLKIN-
21	RxECLKIN+	22	RxEIN3-
23	RxEIN3+	24	VSS
25	VSS	26	NC
27	VSS	28	VCC
29	VCC	30	VCC

Note1: Start from left side; this drawing is only for reference.

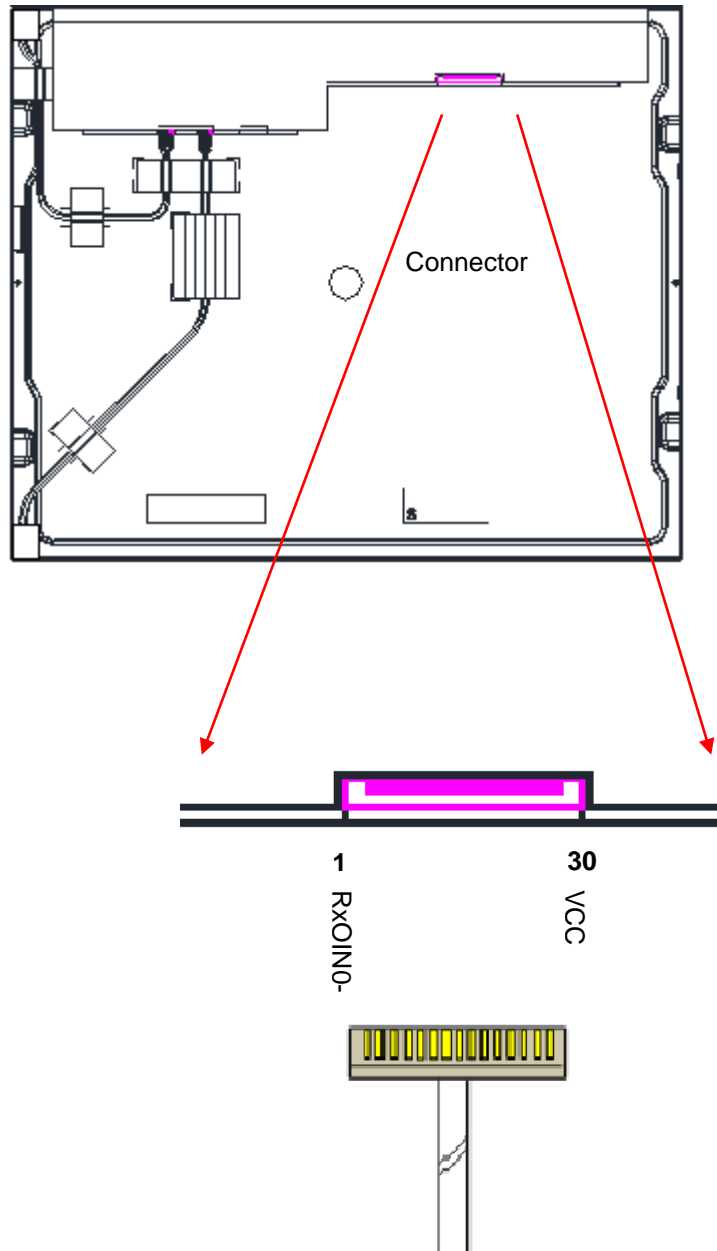

Note2: Input signals of odd and even clock shall be the same timing.

Note3: Please follow VESA.

6.4 The Input Data Format

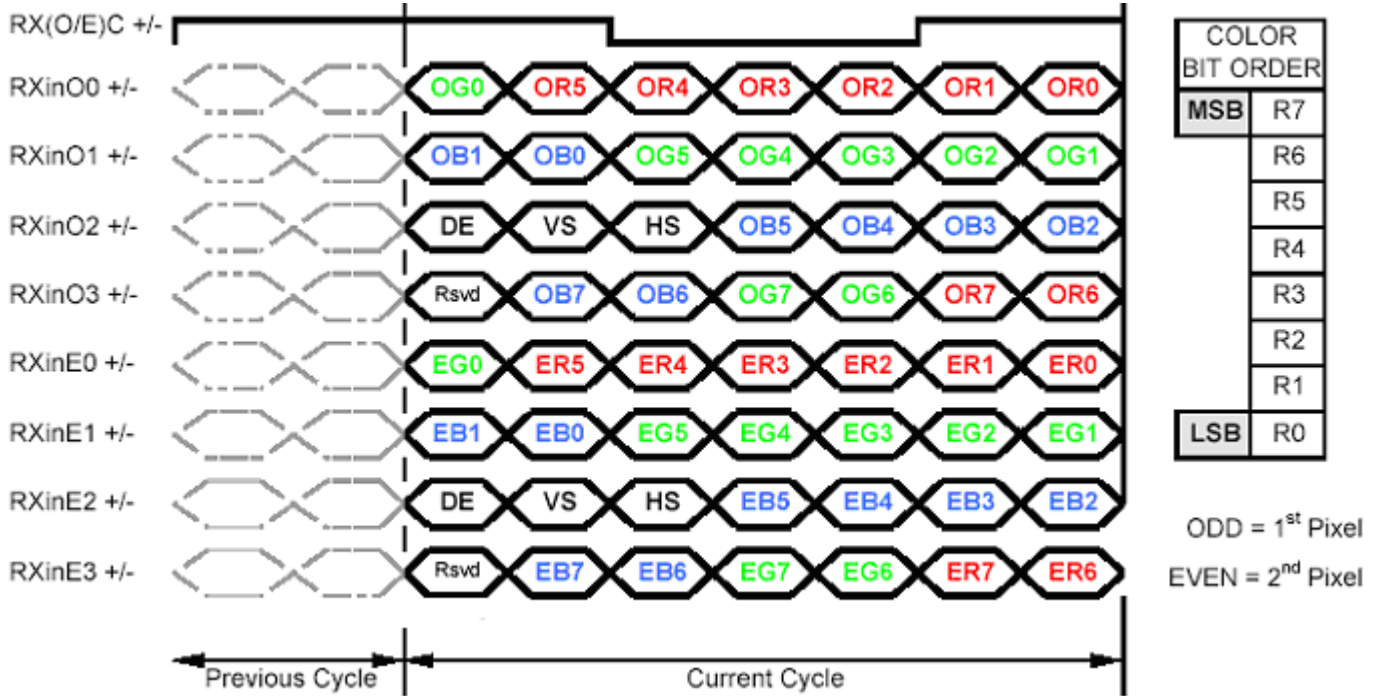

- Note1: Normally DE mode only. VS and HS on EVEN channel are not used.
- Note2: Please follow VESA.
- Note3: 8-bit in

AUO Display+

6.5 Interface Timing

6.5.1 Timing Characteristics

Signal	Symbol	Min.	Typ.	Max.	Unit	
Clock Frequency	$1/T_{\text{Clock}}$	45	54	67.5	MHz	
Vertical Section	Period	T_V	1032	1066	1150	T_{Line}
	Active	T_{VD}	1024	1024	1024	
	Blanking	T_{VB}	8	42	126	
Horizontal Section	Period	T_H	780	844	2047	T_{Clock}
	Active	T_{HD}	640	640	640	
	Blanking	T_{HB}	140	204	-	
Frame Rate	F	50	60	75	Hz	

Note : DE mode.

6.5.2 Input Timing Diagram

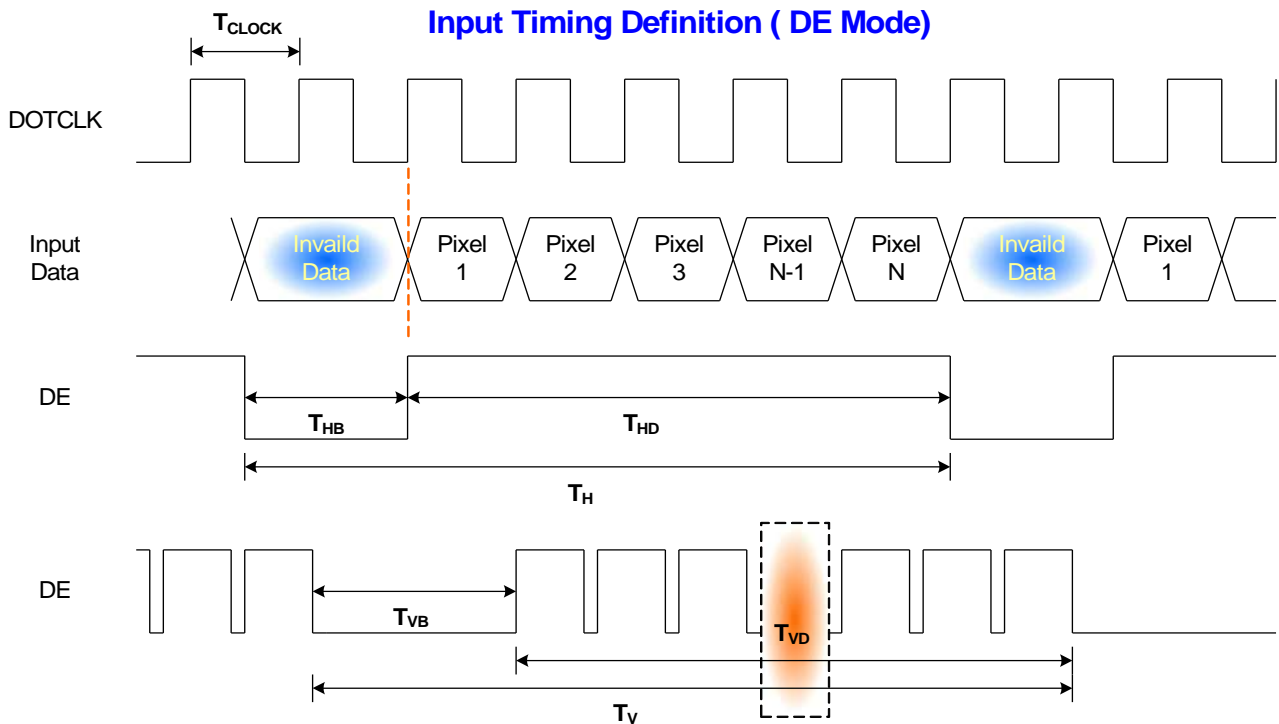

AUO Display+

6.6 Power ON/OFF Sequence

VDD power and lamp on/off sequence is as below. Interface signals are also shown in the chart. Signals from any system shall be Hi-Z state or low level when VDD is off.

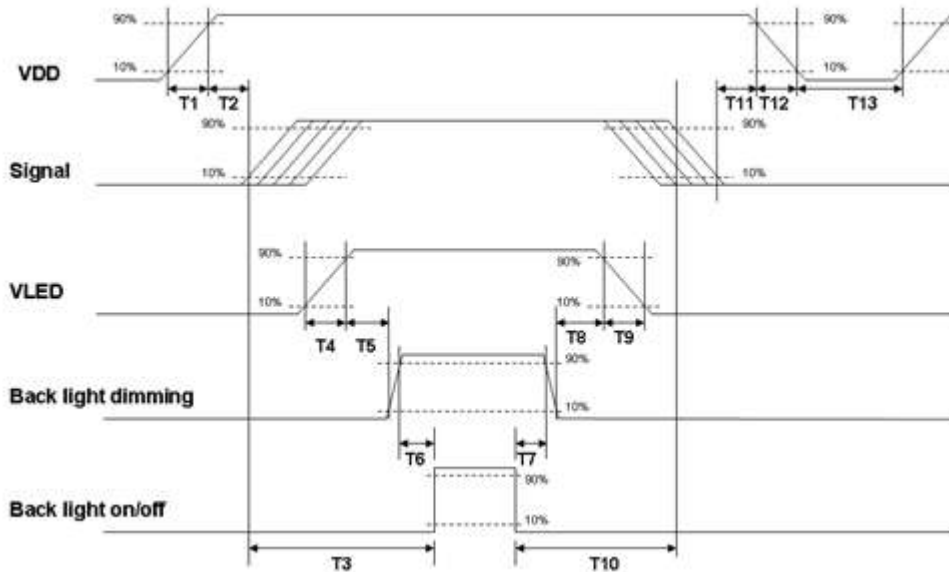

Power ON/OFF sequence timing

Parameter	Value			Units
	Min.	Typ.	Max.	
T1	0.5	-	10	[ms]
T2	30	40	50	[ms]
T3	200	-	--	[ms]
T4	0.5	-	10	[ms]
T5	10	-	-	[ms]
T6	10	-	-	[ms]
T7	0	-	-	[ms]
T8	10	-	-	[ms]
T9	-	-	10	[ms]
T10	110	-	-	[ms]
T11	0	16	50	[ms]
T12	0	-	10	[ms]
T13	1000	-	-	[ms]

The above on/off sequence should be applied to avoid abnormal function in the display. Please make sure to turn off the power when you plug the cable into the input connector or pull the cable out of the connector.

7. Reliability Test Criteria

Items	Required Condition	Note
Temperature Humidity Bias	50 °C /80%,300Hr	
High Temperature Operation	50 °C, 300Hr (center point of panel surface)	
Low Temperature Operation	0 °C, 300Hr	
Hot Storage	60 °C, 300 hours	
Cold Storage	-20 °C, 300 hours	
Thermal Shock Test	-20 °C /30 min ,60 °C /30 min ,100cycles, 40 °C minimum ramp rate	
Shock Test (Non-Operating)	50G,20ms,Half-sine wave,(+-X,+-Y,+-Z)	
Vibration Test (Non-Operating)	1.5Grms, 10~200~10Hz, Sine wave 30mins/axis, 3 direction (X, Y, Z)	
ESD	Contact : ± 8KV/ operation, Class B Air : ± 15KV / operation, Class B	Note 1

Note1: According to EN61000-4-2 , ESD class B: Some performance degradation allowed. No data lost . Self-recoverable. No hardware failures.

Note2:

- Water condensation is not allowed for each test items.
- Each test is done by new TFT-LCD module. Don't use the same TFT-LCD module repeatedly for reliability test.
- The reliability test is performed only to examine the TFT-LCD module capability.
- To inspect TFT-LCD module after reliability test, please store it at room temperature and room humidity for 24 hours at least in advance.
- No function failure occurs.

AUO Display+

8. Mechanical Characteristics

8.1 LCM Outline Dimension:

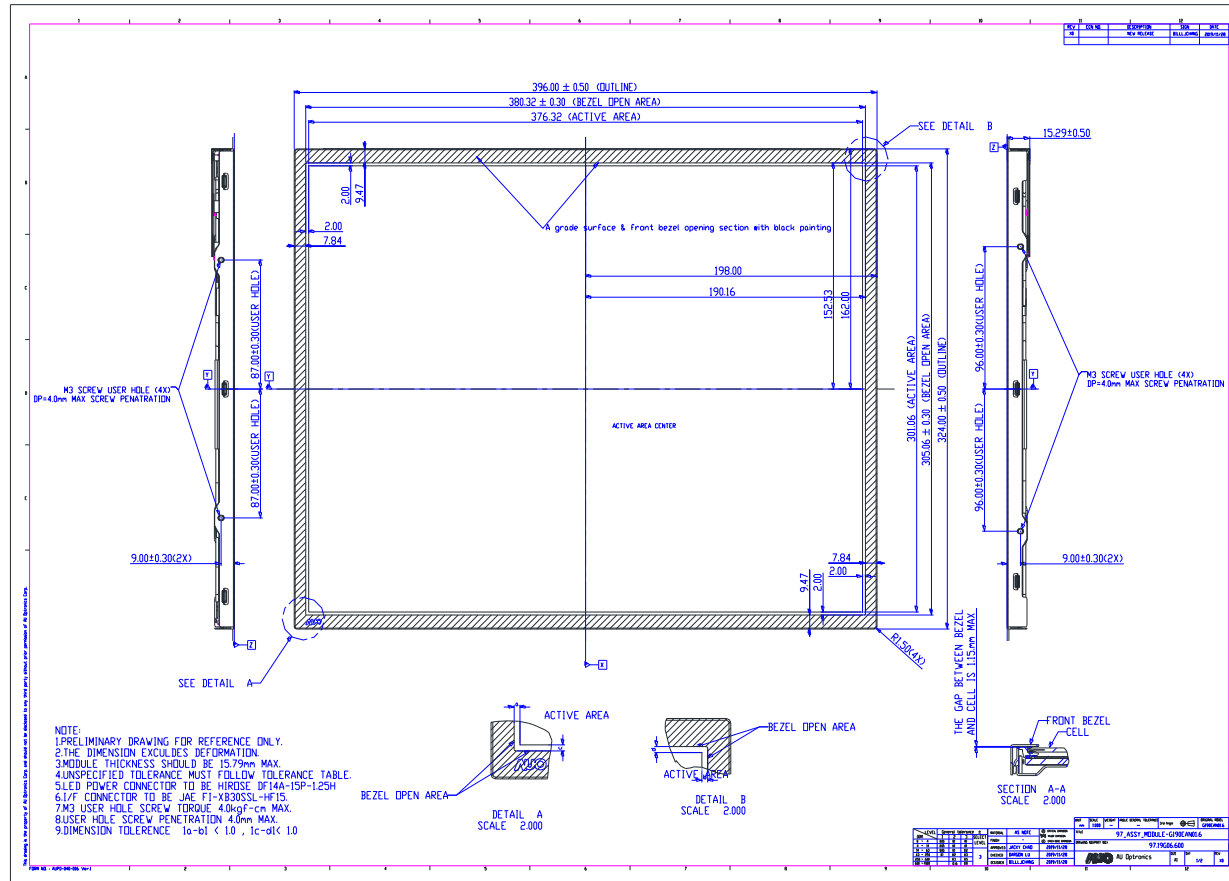

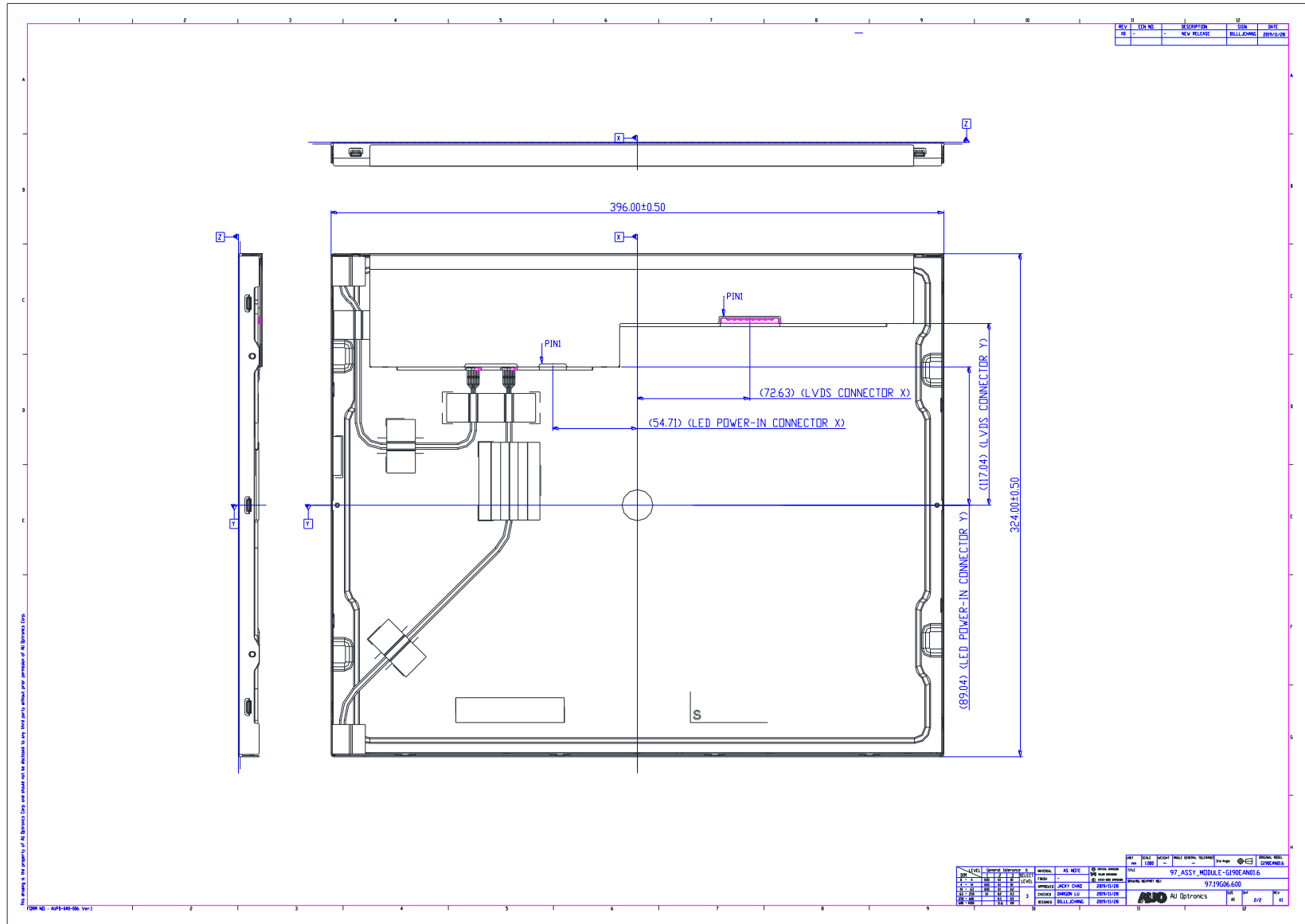

G190EAN01.6 ver. 2

AUO Display+

9. Label and Packaging

9.1 Shipping Label (on the rear side of TFT-LCD display)

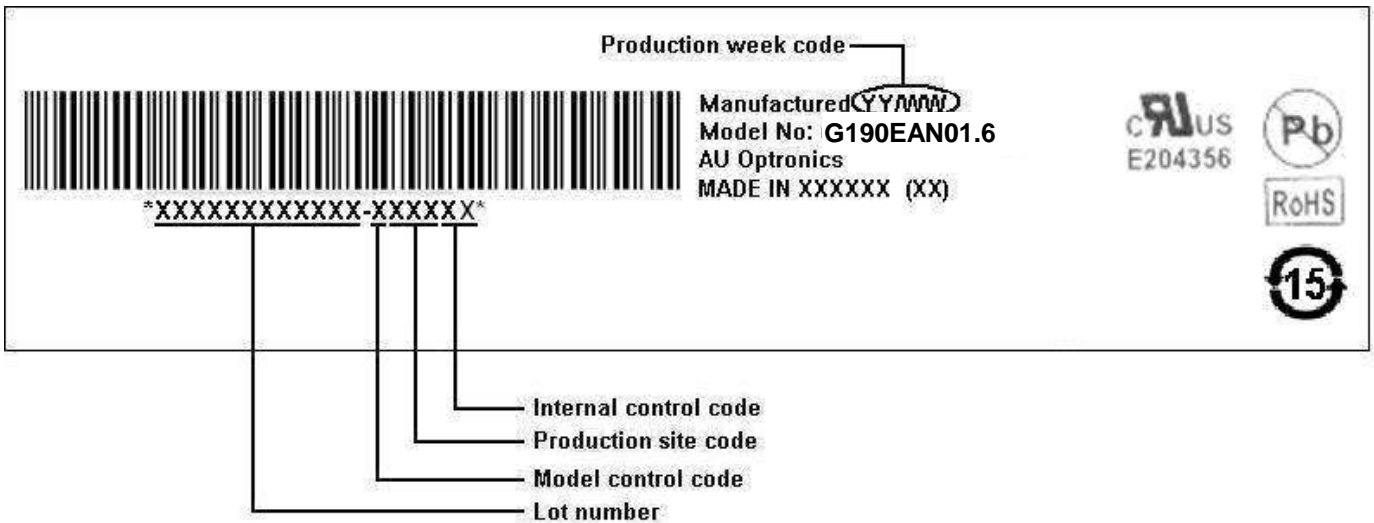

9.2 Carton Package

9.2 Packaging

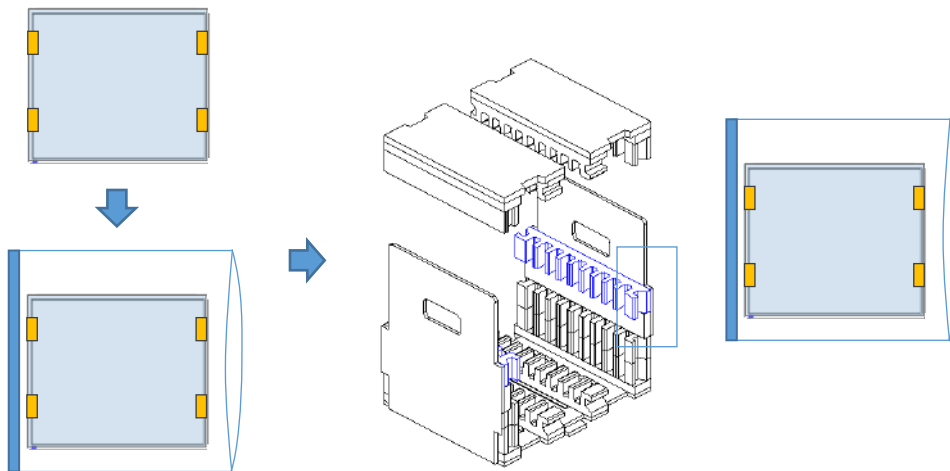

Max capacity: 9pcs G190EAN01.6 per carton

Max weight: 17.6 kg per carton

Carton size: 474mm(L)* 380mm(W)*417mm(H)

Pallet size: 1150 mm * 980 mm * 132mm

Box stacked

Module by air_Max: (2 *3) *3 layers, one pallet put 18 boxes, total 162pcs panels.

Module by sea_Max: (2 *3) *3 layers+ (2 *3) *1 layers, two pallet put 24 boxes, total 216pcs panels.

Module by sea_HQ_Max: (2 *3) *3 layers+(2 *3) *2 layers, two pallet put 30 boxes, total 270pcs module.

