

Doc. Number :

- Tentative Specification
- Preliminary Specification
- Approval Specification

MODEL NO.: G156HCE
SUFFIX: L01

Customer:	
APPROVED BY	SIGNATURE
<u>Name / Title</u> _____	_____
Note	
<hr/> Please return 1 copy for your confirmation with your signature and comments.	

Approved By	Checked By	Prepared By
陳立錚	林秋森	阮志昌

CONTENTS

1. GENERAL DESCRIPTION	5
1.1 OVERVIEW	5
1.2 GENERAL SPECIFICATIONS	5
2. MECHANICAL SPECIFICATIONS	6
3. ABSOLUTE MAXIMUM RATINGS	7
3.1 ABSOLUTE RATINGS OF ENVIRONMENT	7
3.2 ELECTRICAL ABSOLUTE RATINGS	8
3.2.1 TFT LCD MODULE	8
3.2.2 BACKLIGHT CONVERTER.....	8
4. ELECTRICAL SPECIFICATIONS	9
4.1 FUNCTION BLOCK DIAGRAM	9
4.2. INTERFACE CONNECTIONS	10
4.3 ELECTRICAL CHARACTERISTICS	11
4.3.1 LCD ELETRONICS SPECIFICATION	11
4.3.2 BACKLIGHT UNIT.....	14
4.4 LVDS INPUT SIGNAL SPECIFICATIONS	15
4.4.1 LVDS DATA MAPPING TABLE	15
4.4.2 COLOR DATA INPUT ASSIGNMENT.....	16
4.5 DISPLAY TIMING SPECIFICATIONS	17
4.6 POWER ON/OFF SEQUENCE.....	19
4.7 SCANNING DIRECTION	20
5. OPTICAL CHARACTERISTICS	21
5.1 TEST CONDITIONS	21
5.2 OPTICAL SPECIFICATIONS	21
6. RELIABILITY TEST ITEM	24
7. PACKING	25
7.1 PACKING SPECIFICATIONS	25
7.2 PACKING METHOD	25
7.3 UN-PACKING METHOD	26
8. MODULE LABEL.....	27
8.1 INX MODULE LABEL	27
9. PRECAUTIONS	28
9.1 ASSEMBLY AND HANDLING PRECAUTIONS	28
9.2 STORAGE PRECAUTIONS	28
9.3 OPERATION PRECAUTIONS	28

9.4 SAFETY PRECAUTIONS	28
9.5 SAFETY STANDARDS	29
9.6 OTHER	29
MECHANICAL CHARACTERISTICS	30

REVISION HISTORY

Version	Date	Page	Description
2.0	Jun.11, 2018	All	Spec Ver. 2.0 was first issued.
2.1	Dec.20, 2018	4	Module Weight Typ from 1050g(Typ) to 1055g(Typ).
		4	Module Weight Max from 1092g(Max) to 1097g(Max).
		8	4.3.1 Power Supply Voltage Min from 3V to 3.15V.
		10	4.3.2 Backlight off Max from 0.8V to 0.15V.
		11	4.3.3 Delete BACKLIGHT PIN ASSIGNMENT table.
		15	4.6 Modify power sequence diagram.
		15	Modify Timing Specifications T6 、 T7 、 T9 & Note.
		21	7.1 18 to 13 pieces per box of LCD modules
2.2	Jul.02, 2020	21	Weight from about 21.5Kg to 15.6Kg(18 modules per case)
		21	7.2 Modify PACKING METHOD Figure.
		22	7.3 Modify UN-PACKING METHOD Figure.
		8	Modify 3.2.1 TFT LCD MODULE Power Supply Voltage Vcc Max from 3.6V to 4.0V.
		9	Modify 4.2. INTERFACE CONNECTIONS PIN ASSIGNMENT:PIN 17 function.
		9	Add note(3)
2.3	Feb.07, 2022	18	Add 4.7 SCANNING DIRECTION
		All	EC:C2 to C3 spec Ver. 2.3 was first issued.

1. GENERAL DESCRIPTION

1.1 OVERVIEW

G156HCE-L01 is a 15.6" TFT Liquid Crystal Display module with WLED Backlight unit and 40 pins 2ch-LVDS interface. This module supports 1920 x 1080 FHD AAS mode and can display 16,194,277 colors.

1.2 GENERAL SPECIFICATIONS

Item	Specification	Unit	Note
Screen Size	15.6" real diagonal		
Driver Element	a-si TFT active matrix	-	-
Pixel Number	1920 x R.G.B. x 1080	pixel	-
Pixel Pitch	0.17925 (H) x 0.17925 (V)	mm	-
Pixel Arrangement	RGB vertical stripe	-	-
Display Colors	16.2M	color	-
Transmissive Mode	Normally Black	-	-
Surface Treatment	AG type, 3H hard coating,	-	-
Luminance, White	450(Typ.)	Cd/m2	
Color Gamut	72 % of NTSC(Typ.)	-	-
Power Consumption	(Total 16 W (Typ) @ cell 4 W (Typ), BL 12 W (Typ))		

2. MECHANICAL SPECIFICATIONS

Item		Min.	Typ.	Max.	Unit	Note
Module Size	Horizontal (H)	363.3	363.8	364.3	mm	
	Vertical (V)	215.4	215.9	216.4	mm	
	Thickness (T)	8.8	9.3	9.8	mm	
Bezel Area	Horizontal	346.76	347.06	347.36	mm	
	Vertical	196.19	196.49	196.79	mm	
Active Area	Horizontal	-	344.16	-	mm	
	Vertical	-	193.59	-	mm	
Weight		-	1055	1097	g	

3. ABSOLUTE MAXIMUM RATINGS

3.1 ABSOLUTE RATINGS OF ENVIRONMENT

Item	Symbol	Value		Unit	Note
		Min.	Max.		
Storage Temperature	Tst	-40	90	°C	(1), (2)
Operating Ambient Temperature	Top	-30	85	°C	(1), (2)

Note (1) Temperature and relative humidity range is shown in the figure below.

- (a) 90 %RH Max. ($T_a \leq 40$ °C).
- (b) Wet-bulb temperature should be 39 °C Max. ($T_a > 40$ °C).
- (c) No condensation.

- (2) The absolute maximum rating values of this product are not allowed to be exceeded at any times. The module should not be used over the absolute maximum rating value. It will cause permanently unrecoverable function fail in such an condition

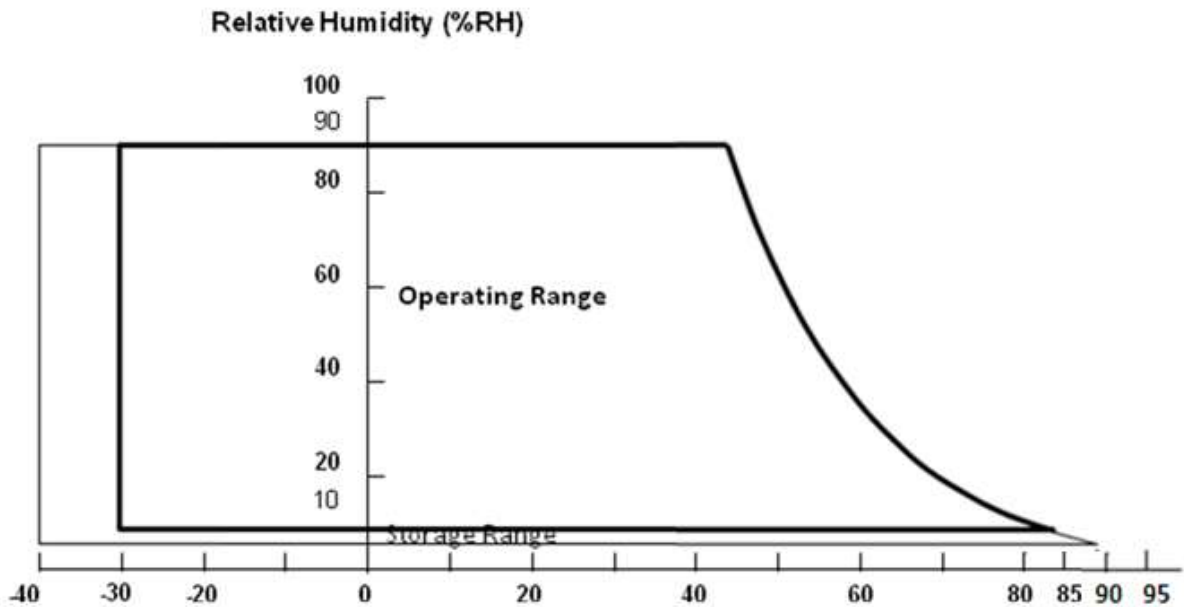

3.2 ELECTRICAL ABSOLUTE RATINGS

3.2.1 TFT LCD MODULE

Item	Symbol	Value		Unit	Note
		Min.	Max.		
Power Supply Voltage	V _{CC}	-0.3	4.0	V	(1)
Logic Input Voltage	V _{IN}	-0.3	4.0	V	

3.2.2 BACKLIGHT CONVERTER

Item	Symbol	Value			Unit	Note
		Min.	Typ	Max.		
Converter Voltage	LED_V _{in}	0	12.0	18.0	V	(1), (2)
Enable Voltage	LED_EN	0	3.3 / 5	7	V	Duty=100%
Backlight Adjust	LED_PWM	0	3.3 / 5	7	V	(1), (2) Pulse Width ≤ 10msec. and Duty ≤ 10%

Note (1) Permanent damage to the device may occur if maximum values are exceeded. Function operation should be restricted to the conditions described under Normal Operating Conditions.

Note (2) Specified values are for input pin of LED light bar at T_a=25±2 °C (Refer to 4.3.3 and 4.3.4 for further information)

4. ELECTRICAL SPECIFICATIONS

4.1 FUNCTION BLOCK DIAGRAM

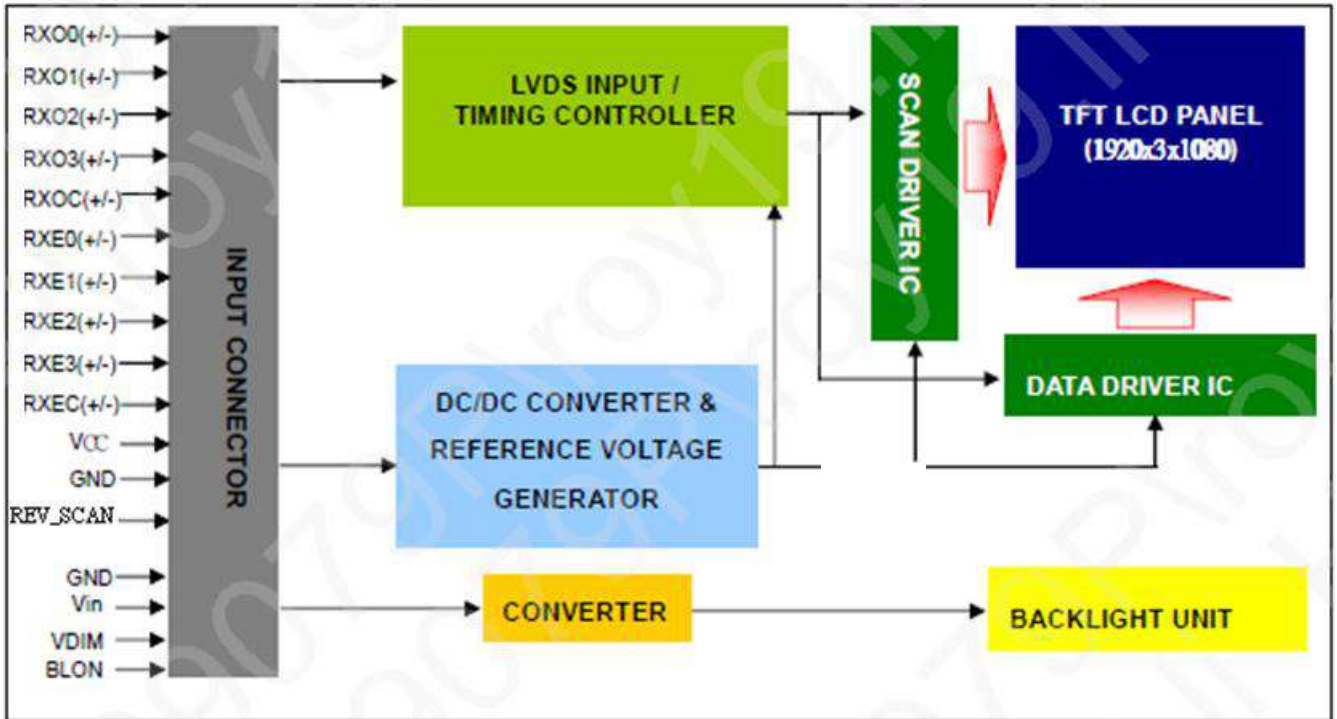

4.2. INTERFACE CONNECTIONS

PIN ASSIGNMENT

Pin	Name	Description	Note
1	LED_Vcc	+12V Vi power supply	-
2	LED_Vcc	+12V Vi power supply	-
3	LED_Vcc	+12V Vi power supply	-
4	LED_Vcc	+12V Vi power supply	-
5	GND	Ground	-
6	GND	Ground	-
7	GND	Ground	-
8	GND	Ground	-
9	LED_EN	Enable pin	-
10	LED_PWM	Backlight Adjust	-
11	LCD_VCC	LCD logic and driver power 3.3V	-
12	LCD_VCC	LCD logic and driver power 3.3V	-
13	LCD_VCC	LCD logic and driver power 3.3V	-
14	NC	Not connection, this pin should be open	-
15	NC	Not connection, this pin should be open	-
16	NC	Not connection, this pin should be open	-
17	REV_SCAN	Low → Normal Mode. High → Horizontal & Vertical Reverse Scan	(3)
18	RXO0-	Negative LVDS differential data input. Channel O0 (odd)	-
19	RXO0+	Positive LVDS differential data input. Channel O0 (odd)	-
20	RXO1-	Negative LVDS differential data input. Channel O1 (odd)	-
21	RXO1+	Positive LVDS differential data input. Channel O1 (odd)	-
22	RXO2-	Negative LVDS differential data input. Channel O2 (odd)	-
23	RXO2+	Positive LVDS differential data input. Channel O2 (odd)	-
24	LCD GND	LCD logic and driver ground	-
25	RXOC-	Negative LVDS differential clock input. (odd)	-
26	RXOC+	Positive LVDS differential clock input. (odd)	-
27	LCD GND	LCD logic and driver ground	-
28	RXO3-	Negative LVDS differential data input. Channel O3(odd)	-
29	RXO3+	Positive LVDS differential data input. Channel O3 (odd)	-
30	RXE0-	Negative LVDS differential data input. Channel E0 (even)	-
31	RXE0+	Positive LVDS differential data input. Channel E0 (even)	-
32	RXE1-	Negative LVDS differential data input. Channel E1 (even)	-
33	RXE1+	Positive LVDS differential data input. Channel E1 (even)	-
34	LCD GND	LCD logic and driver ground	-
35	RXE2-	Negative LVDS differential data input. Channel E2 (even)	-
36	RXE2+	Positive LVDS differential data input. Channel E2 (even)	-
37	RXEC-	Negative LVDS differential clock input. (even)	-
38	RXEC+	Positive LVDS differential clock input. (even)	-
39	RXE3-	Negative LVDS differential data input. Channel E3 (even)	-
40	RXE3+	Positive LVDS differential data input. Channel E3 (even)	-

Note (1) Connector Part No.: I-PEX 20455-040E-76 or equivalent.

Note (2) User's connector Part No.: I-PEX 20453-040T-03 or equivalent.

Note (3) "Low" stands for 0V. "High" stands for 3.3V.

REV_SCAN PIN :

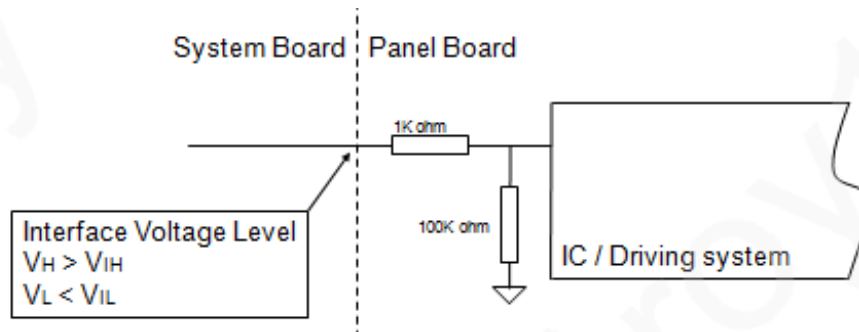

4.3 ELECTRICAL CHARACTERISTICS

4.3.1 LCD ELETRONICS SPECIFICATION

Parameter	Symbol	Value			Unit	Note
		Min.	Typ.	Max.		
Power Supply Voltage	V _{CC}	3.15	3.3	3.6	V	-
Ripple Voltage	V _{RP}	-	-	150	mV	-
Rush Current	I _{RUSH}	-	-	3	A	(2)
Power Supply Current	White	-	1.22	1.5	A	(3)a
	Black	-	0.51	0.7	A	(3)b
	Vertical Stripe	-	0.82	1	A	(3)c
Power Consumption	PLCD	-	4	5	Watt	(4)
LVDS differential input voltage	V _{id}	200		600	mV	(5)
LVDS common input voltage	V _{ic}	1.0	1.2	1.4	V	(5)
LVDS terminating resistor	R _T		100		ohm	

Note (1) The ambient temperature is $T_a = 25 \pm 2 \text{ }^\circ\text{C}$.

Note (2) Measurement Conditions:

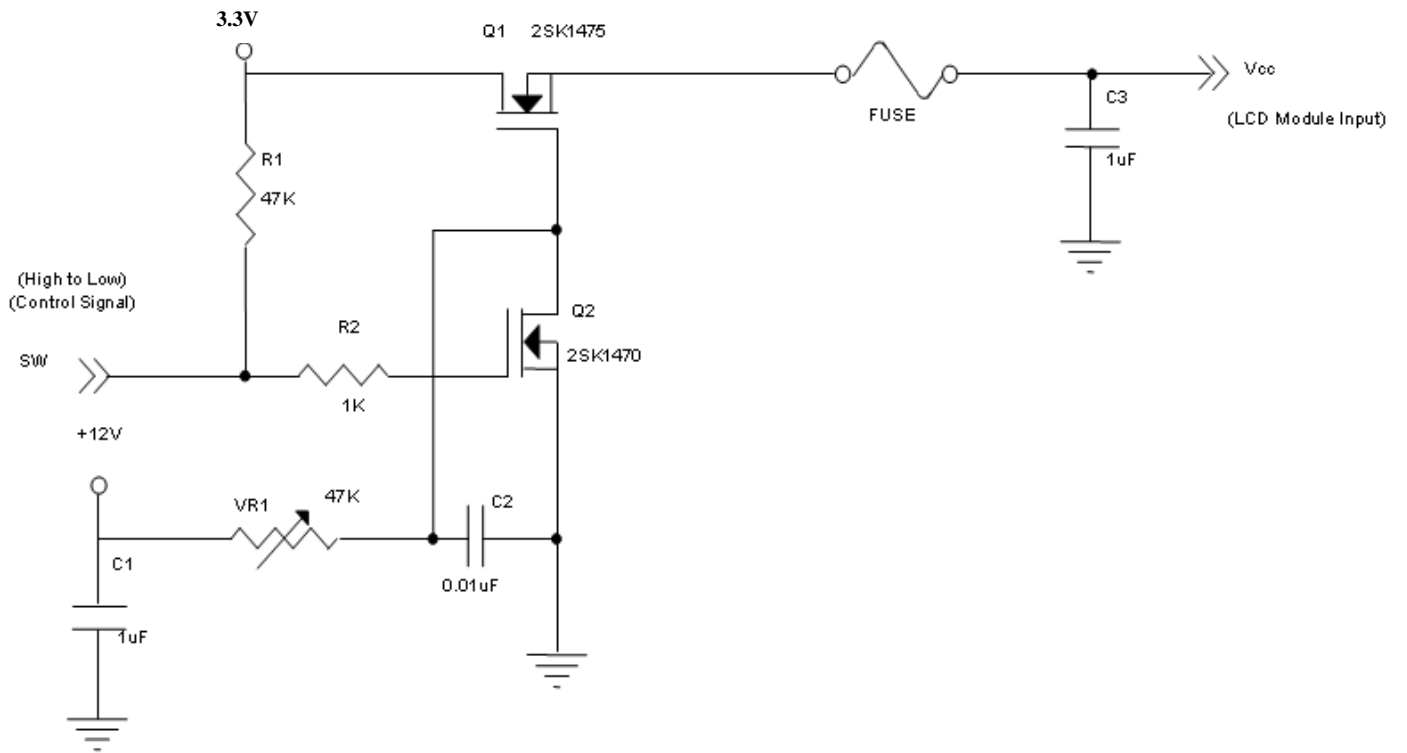

Vcc rising time is 470µs

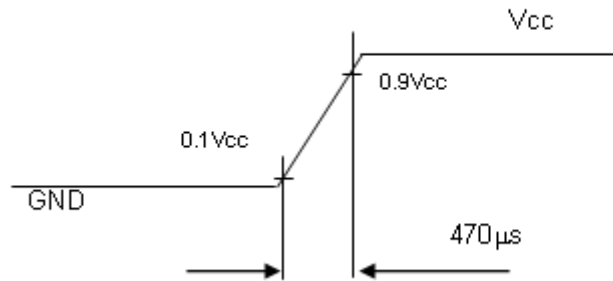

Note (3) The specified power supply current is under the conditions at $V_{cc} = 3.3 \text{ V}$, $T_a = 25 \pm 2 \text{ }^\circ\text{C}$, $f_r = 60\text{Hz}$, whereas a power dissipation check pattern below is displayed.

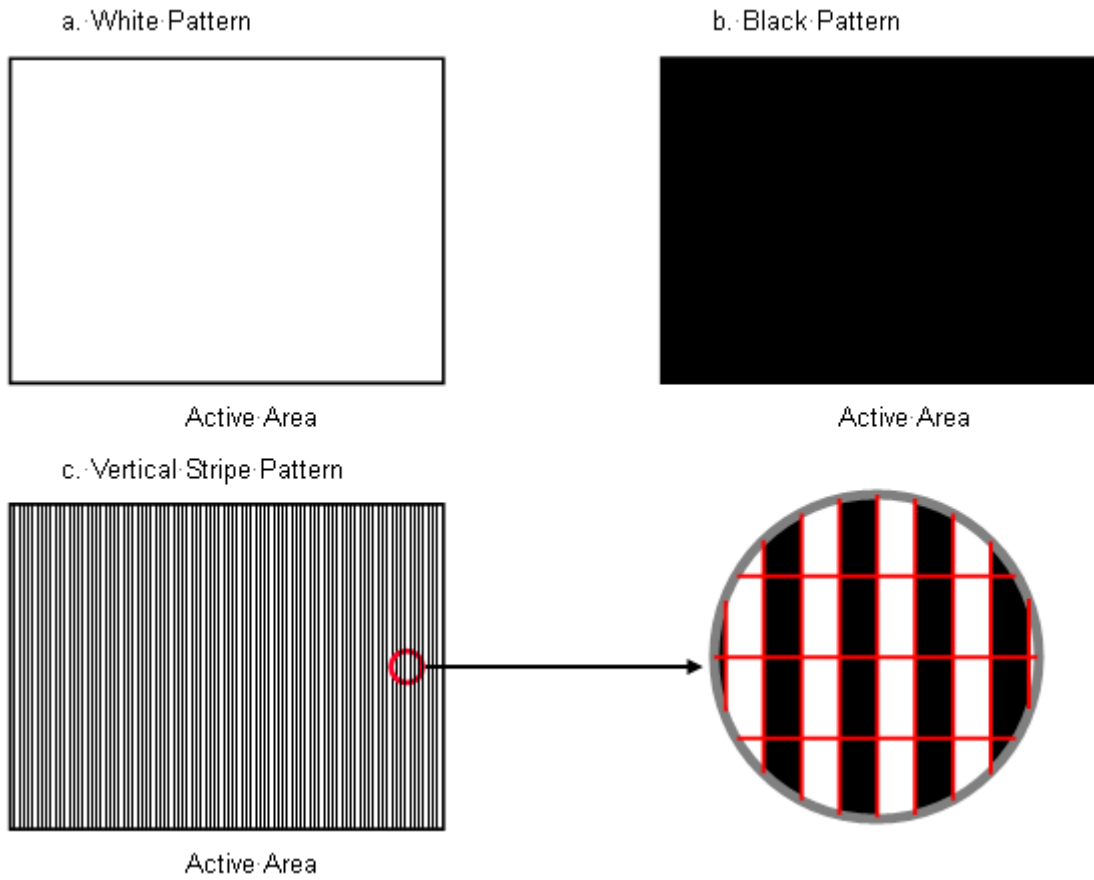

Note (4) The power consumption is specified at the pattern with the maximum current.

Note (5) VID waveform condition

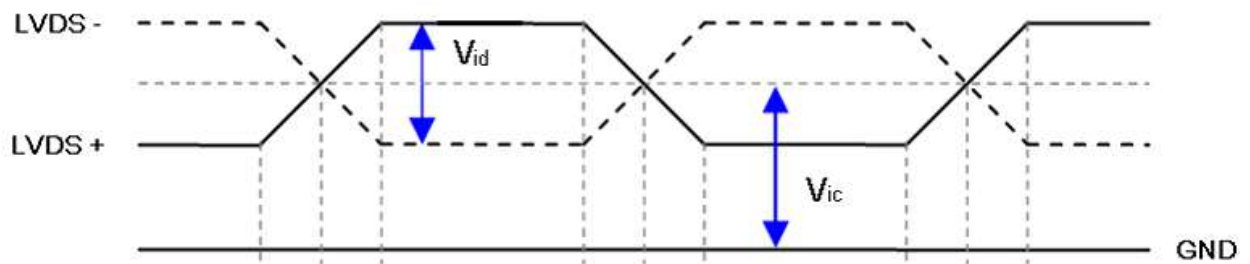

4.3.2 BACKLIGHT UNIT

Parameter	Symbol	Value			Unit	Note	
		Min.	Typ.	Max.			
Converter Power Supply Voltage	LED_Vin	10.8	12.0	13.2	V		
Converter Power Supply Current	li	0.8	1.0	1.2	A	@LED_Vin= 12V Duty=100%	
Converter Input Rush Current	lirsh			3	A	@LED_Vin rising = 1mS	
Power Consumption	P _{LED}		12		W	@ LED_Vin = 12V Duty=100%	
EN Control Level	Backlight on	LED_EN	2.0	5	5.5	V	
	Backlight off		0	0	0.15		
PWM Control Level	PWM High Level	LED_PWM	2.0	3.3	5.0	V	
	PWM Low Level		0	0	0.15		
PWM Control Duty Ratio			10	--	100	%	
PWM Control Frequency		f _{PWM}	190	200	20k	Hz	
LED Life Time		L _L	50,000			Hrs	(2)

Note (1) LED light bar input voltage and current are measured by utilizing a true RMS multimeter as shown below:

Note (2) The lifetime of LED is estimated data and defined as the time when it continues to operate under the conditions at $T_a = 25 \pm 2^\circ\text{C}$ and Duty 100% until the brightness becomes $\leq 50\%$ of its original value. Operating LED under high temperature environment will reduce life time and lead to color shift.

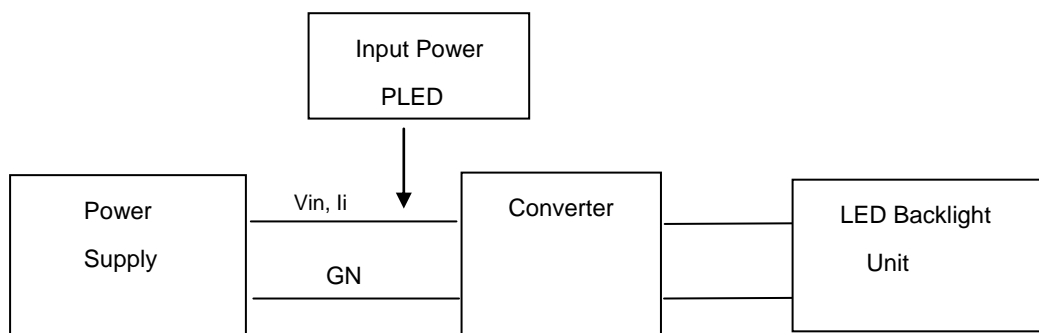

4.4 LVDS INPUT SIGNAL SPECIFICATIONS

4.4.1 LVDS DATA MAPPING TABLE

LVDS Channel O0	LVDS output	D7	D6	D4	D3	D2	D1	D0
	Data order	OG0	OR5	OR4	OR3	OR2	OR1	OR0
LVDS Channel O1	LVDS output	D18	D15	D14	D13	D12	D9	D8
	Data order	OB1	OB0	OG5	OG4	OG3	OG2	OG1
LVDS Channel O2	LVDS output	D26	D25	D24	D22	D21	D20	D19
	Data order	DE	NA	NA	OB5	OB4	OB3	OB2
LVDS Channel O3	LVDS output	D23	D17	D16	D11	D10	D5	D27
	Data order	NA	OB7	OB6	OG7	OG6	OR7	OR6
LVDS Channel E0	LVDS output	D7	D6	D4	D3	D2	D1	D0
	Data order	EG0	ER5	ER4	ER3	ER2	ER1	ER0
LVDS Channel E1	LVDS output	D18	D15	D14	D13	D12	D9	D8
	Data order	EB1	EB0	EG5	EG4	EG3	EG2	EG1
LVDS Channel E2	LVDS output	D26	D25	D24	D22	D21	D20	D19
	Data order	DE	NA	NA	EB5	EB4	EB3	EB2
LVDS Channel E3	LVDS output	D23	D17	D16	D11	D10	D5	D27
	Data order	NA	EB7	EB6	EG7	EG6	ER7	ER6

4.4.2 COLOR DATA INPUT ASSIGNMENT

The brightness of each primary color (red, green and blue) is based on the 8-bit gray scale data input for the color. The higher the binary input, the brighter the color. The table below provides the assignment of color versus data input.

Color		Data Signal																							
		Red								Green								Blue							
		R7	R6	R5	R4	R3	R2	R1	R0	G7	G6	G5	G4	G3	G2	G1	G0	B7	B6	B5	B4	B3	B2	B1	B0
Basic Colors	Black	0	0	0	0	0	0	0	0	0	0	0	0	0	0	0	0	0	0	0	0	0	0	0	0
	Red	1	1	1	1	1	1	1	1	0	0	0	0	0	0	0	0	0	0	0	0	0	0	0	0
	Green	0	0	0	0	0	0	0	0	1	1	1	1	1	1	1	1	0	0	0	0	0	0	0	0
	Blue	0	0	0	0	0	0	0	0	0	0	0	0	0	0	0	1	1	1	1	1	1	1	1	1
	Cyan	0	0	0	0	0	0	0	0	1	1	1	1	1	1	1	1	1	1	1	1	1	1	1	1
	Magenta	1	1	1	1	1	1	1	1	0	0	0	0	0	0	0	0	1	1	1	1	1	1	1	1
	Yellow	1	1	1	1	1	1	1	1	1	1	1	1	1	1	1	1	0	0	0	0	0	0	0	0
	White	1	1	1	1	1	1	1	1	1	1	1	1	1	1	1	1	1	1	1	1	1	1	1	1
Gray Scale Of Red	Red(0) / Dark	0	0	0	0	0	0	0	0	0	0	0	0	0	0	0	0	0	0	0	0	0	0	0	
	Red(1)	0	0	0	0	0	0	0	1	0	0	0	0	0	0	0	0	0	0	0	0	0	0	0	
	Red(2)	0	0	0	0	0	0	1	0	0	0	0	0	0	0	0	0	0	0	0	0	0	0	0	
	⋮	⋮	⋮	⋮	⋮	⋮	⋮	⋮	⋮	⋮	⋮	⋮	⋮	⋮	⋮	⋮	⋮	⋮	⋮	⋮	⋮	⋮	⋮		
	⋮	⋮	⋮	⋮	⋮	⋮	⋮	⋮	⋮	⋮	⋮	⋮	⋮	⋮	⋮	⋮	⋮	⋮	⋮	⋮	⋮	⋮	⋮		
	Red(253)	1	1	1	1	1	1	0	1	0	0	0	0	0	0	0	0	0	0	0	0	0	0	0	
	Red(254)	1	1	1	1	1	1	1	0	0	0	0	0	0	0	0	0	0	0	0	0	0	0	0	
	Red(255)	1	1	1	1	1	1	1	1	0	0	0	0	0	0	0	0	0	0	0	0	0	0	0	
Gray Scale Of Green	Green(0)/Dark	0	0	0	0	0	0	0	0	0	0	0	0	0	0	0	0	0	0	0	0	0	0	0	
	Green(1)	0	0	0	0	0	0	0	0	0	0	0	0	0	0	1	0	0	0	0	0	0	0	0	
	Green(2)	0	0	0	0	0	0	0	0	0	0	0	0	0	1	0	0	0	0	0	0	0	0	0	
	⋮	⋮	⋮	⋮	⋮	⋮	⋮	⋮	⋮	⋮	⋮	⋮	⋮	⋮	⋮	⋮	⋮	⋮	⋮	⋮	⋮	⋮	⋮		
	⋮	⋮	⋮	⋮	⋮	⋮	⋮	⋮	⋮	⋮	⋮	⋮	⋮	⋮	⋮	⋮	⋮	⋮	⋮	⋮	⋮	⋮	⋮		
	Green(253)	0	0	0	0	0	0	0	0	1	1	1	1	1	1	0	1	0	0	0	0	0	0	0	
	Green(254)	0	0	0	0	0	0	0	0	1	1	1	1	1	1	1	0	0	0	0	0	0	0	0	
	Green(255)	0	0	0	0	0	0	0	0	1	1	1	1	1	1	1	1	0	0	0	0	0	0	0	
Gray Scale Of Blue	Blue(0) / Dark	0	0	0	0	0	0	0	0	0	0	0	0	0	0	0	0	0	0	0	0	0	0	0	
	Blue(1)	0	0	0	0	0	0	0	0	0	0	0	0	0	0	0	0	0	0	0	0	0	0	1	
	Blue(2)	0	0	0	0	0	0	0	0	0	0	0	0	0	0	0	0	0	0	0	0	0	1	0	
	⋮	⋮	⋮	⋮	⋮	⋮	⋮	⋮	⋮	⋮	⋮	⋮	⋮	⋮	⋮	⋮	⋮	⋮	⋮	⋮	⋮	⋮	⋮		
	⋮	⋮	⋮	⋮	⋮	⋮	⋮	⋮	⋮	⋮	⋮	⋮	⋮	⋮	⋮	⋮	⋮	⋮	⋮	⋮	⋮	⋮	⋮		
	Blue(253)	0	0	0	0	0	0	0	0	0	0	0	0	0	0	0	1	1	1	1	1	1	1	0	
	Blue(254)	0	0	0	0	0	0	0	0	0	0	0	0	0	0	0	1	1	1	1	1	1	1	0	
	Blue(255)	0	0	0	0	0	0	0	0	0	0	0	0	0	0	0	1	1	1	1	1	1	1	1	

Note (1) 0: Low Level Voltage, 1: High Level Voltage

4.5 DISPLAY TIMING SPECIFICATIONS

The input signal timing specifications are shown as the following table and timing diagram.

Signal	Item	Symbol	Min.	Typ.	Max.	Unit	Note
LVDS Clock	Frequency	F _c	60	70.93	75	MHz	-
	Period	T _c		14.1		ns	
	Input cycle to cycle jitter	T _{rcl}	-0.02*T _c		0.02*T _c	ns	(3)
	Input clock to data skew	TLVCCS	-0.02*T _c		0.02*T _c	ns	(4)
	Spread spectrum modulation range	F _{clkin_mod}	FC*98%		FC*102%	MHz	(5)
	Spread spectrum modulation frequency	F _{SSM}			200	KHz	
Vertical Display Term	Frame Rate	Fr	50	60	60	Hz	T _v =T _v d+T _v b
	Total	T _v	1090	1110	1130	Th	-
	Active Display	T _v d	1080	1080	1080	Th	-
	Blank	T _v b	T _v -T _v d	30	T _v -T _v d	Th	-
Horizontal Display Term	Total	T _h	1050	1065	1075	T _c	T _h =T _h d+T _h b
	Active Display	T _h d	960	960	960	T _c	-
	Blank	T _h b	T _h -T _h d	105	T _h -T _h d	T _c	-

Note (1) Because this module is operated by DE only mode, Hsync and Vsync input signals are ignored.

Note (2) The T_v(T_vd+T_vb) must be integer, otherwise, this module would operate abnormally.

INPUT SIGNAL TIMING DIAGRAM

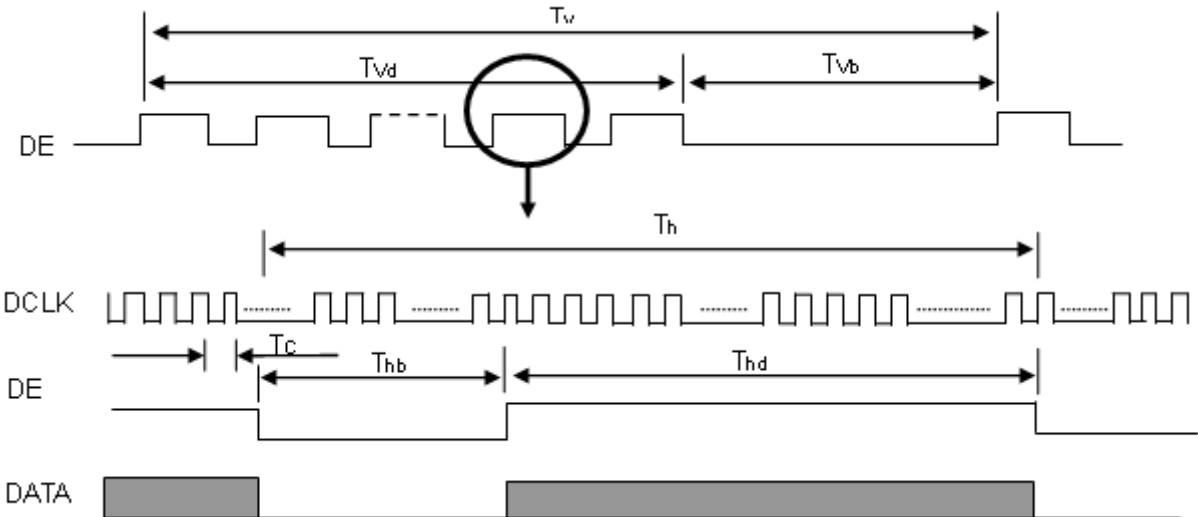

Note (3) The input clock cycle-to-cycle jitter is defined as below figures. $Trcl = |T1 - T|$

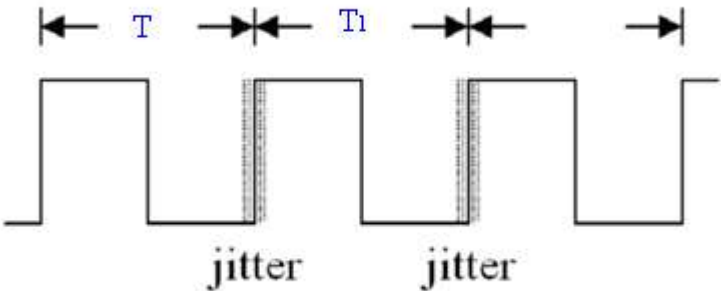

Note (4) Input Clock to data skew is defined as below figures.

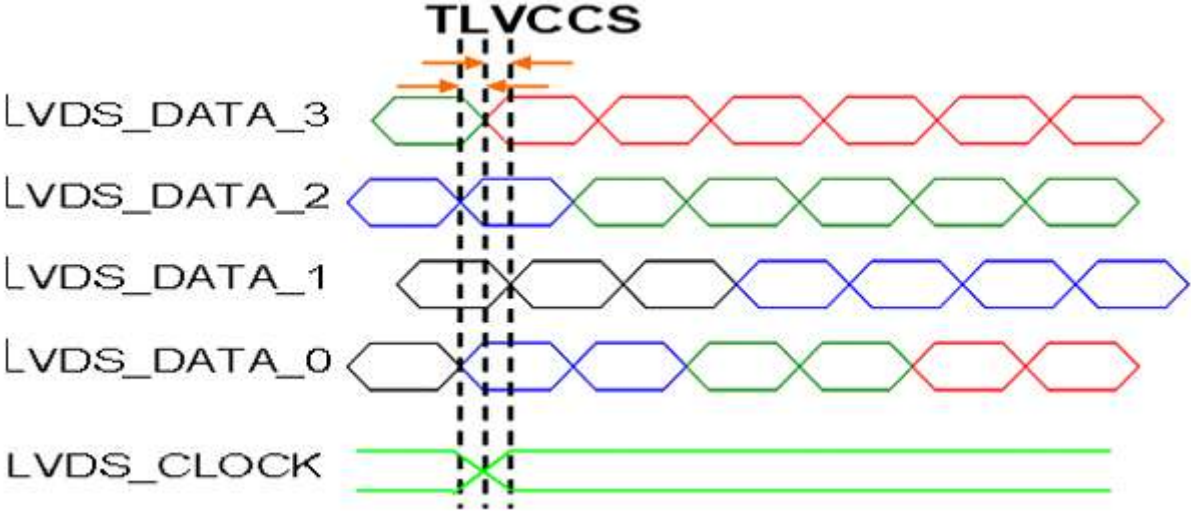

Note (5) The SSCG (Spread spectrum clock generator) is defined as below figures.

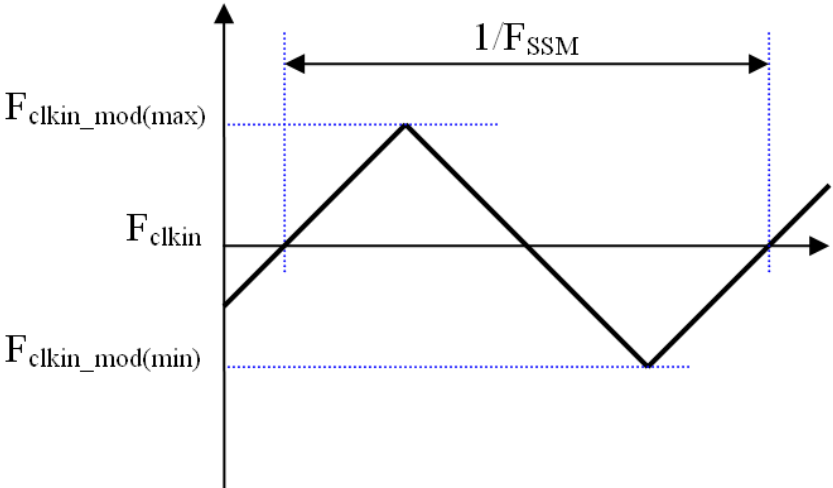

4.6 POWER ON/OFF SEQUENCE

The power sequence specifications are shown as the following table and diagram.

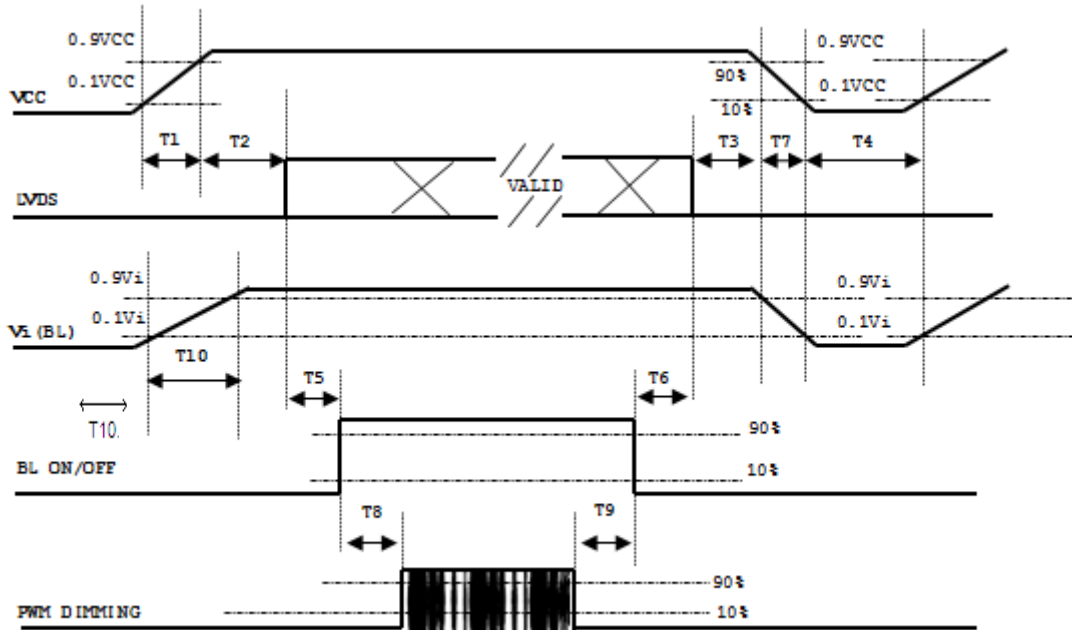

Timing Specifications:

Parameter	Value			Units
	Min	Typ	Max	
T1	0.5	-	10	ms
T2	0	-	50	ms
T3	0	-	50	ms
T4	500	-	-	ms
T5	450	-	-	ms
T6	200	-	-	ms
T7	10	-	100	ms
T8	10	-	-	ms
T9	10	-	-	ms
T10	20	-	50	ms

Note:

- (1) The supply voltage of the external system for the module input should be the same as the definition of Vcc.
- (2) When the backlight turns on before the LCD operation of the LCD turns off, the display may momentarily become abnormal screen.

- (3) In case of VCC = off level, please keep the level of input signals on the low or keep a high impedance.
- (4) T4 should be measured after the module has been fully discharged between power off and on period.
- (5) Interface signal shall not be kept at high impedance when the power is on.
- (6) INX won't take any responsibility for the products which are damaged by the customers not following the Power Sequence.
- (7) There might be slight electronic noise when LCD is turned off (even backlight unit is also off). To avoid this symptom, we suggest "Vcc falling timing" to follow "T7 spec".

4.7 SCANNING DIRECTION

The following figures show the image see from the front view. The arrow indicates the direction of scan.



Fig. 1 Normal scan (PCBA on the bottom side)
(pin 17, REV_SCAN = Low)



Fig. 2 Reverse scan (PCBA on the bottom side)
(pin 17, REV_SCAN = High)

5. OPTICAL CHARACTERISTICS

5.1 TEST CONDITIONS

Item	Symbol	Value	Unit
Ambient Temperature	Ta	25±2	°C
Ambient Humidity	Ha	50±10	%RH
Supply Voltage	According to typical value in "ELECTRICAL CHARACTERISTICS"		
Input Signal			
LED Light Bar Input Current Per Input Pin			

5.2 OPTICAL SPECIFICATIONS

The relative measurement methods of optical characteristics are shown in 5.2 and all items are measured at the center point of screen except white variation. The following items should be measured under the test conditions described in 5.1 and stable environment shown in Note (5).

Item	Symbol	Condition	Min.	Typ.	Max.	Unit	Note	
Color Chromaticity (CIE 1931)	Red	Rx	Typ - 0.05	0.652	Typ + 0.05	-	(1), (5)	
		Ry		0.338				
	Green	Gx		0.333				
		Gy		0.613				
	Blue	Bx		0.150				
		By		0.050				
	White	Wx		0.313				
		Wy		0.329				
Center Luminance of White	L _C	θ _x =0°, θ _y =0° CS-2000 R=G=B=255 Gray scale	360	450	-	cd/m ²	(4), (5)	
Contrast Ratio	CR		600	800	-	-	(2), (5)	
Response Time	T _R		θ _x =0°, θ _y =0°	-	13	18	ms	(3)
	T _F	-		12	17			
White Variation	W	θ _x =0°, θ _y =0°	70	-	-	%	(5), (6)	
Viewing Angle	Horizontal	θ _{x+}	CR ≥ 10	85	89	---	Deg.	(1), (5)
		θ _{x-}		85	89			
	Vertical	θ _{y+}		85	89			
		θ _{y-}		85	89			

Note (1) Definition of Viewing Angle (θ_x, θ_y):

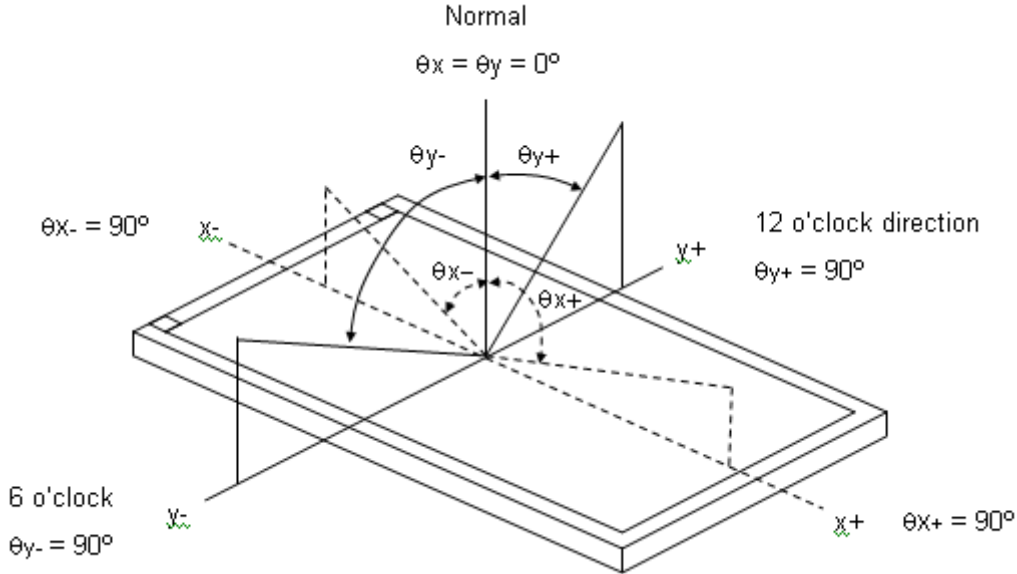

Note (2) Definition of Contrast Ratio (CR):

The contrast ratio can be calculated by the following expression.

$$\text{Contrast Ratio (CR)} = L_{255} / L_0$$

L255: Luminance of gray level 255

L 0: Luminance of gray level 0

$$CR = CR(5)$$

CR (X) is corresponding to the Contrast Ratio of the point X at Figure in Note (6).

Note (3) Definition of Response Time (T_R, T_F):

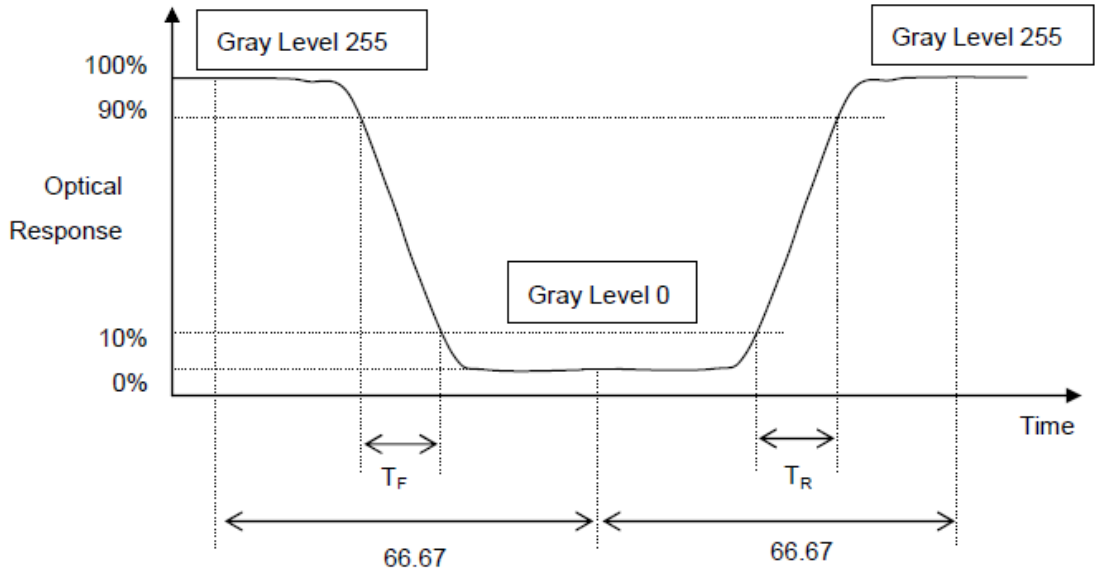

Note (4) Definition of Luminance of White (L_c):

Measure the luminance of gray level 255 at center point

$$L_c = L(5)$$

L(x) is corresponding to the luminance of the point X at Figure in Note (6).

Note (5) Measurement Setup:

The LCD module should be stabilized at given temperature for 30 minutes to avoid abrupt temperature change during measuring. In order to stabilize the luminance, the measurement should be executed after lighting Backlight for 30 minutes in a windless room.

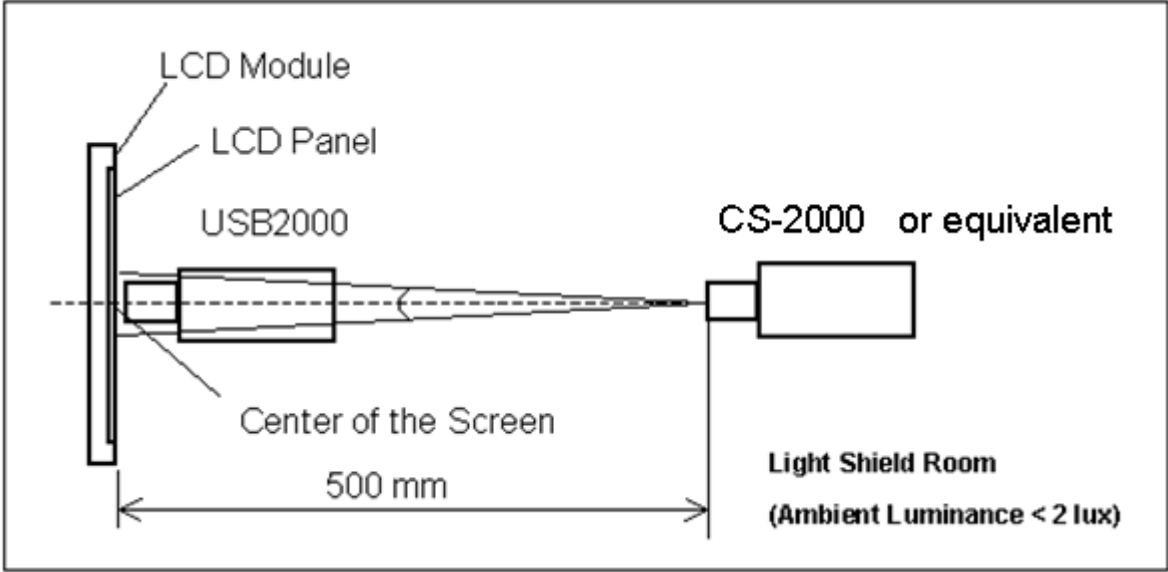

Note (6) Definition of White Variation (δW):

Measure the luminance of gray level 255 at 9 points

$$\delta W = \left(\frac{\text{Minimum } [L(1) \sim L(9)]}{\text{Maximum } [L(1) \sim L(9)]} \right) * 100\%$$

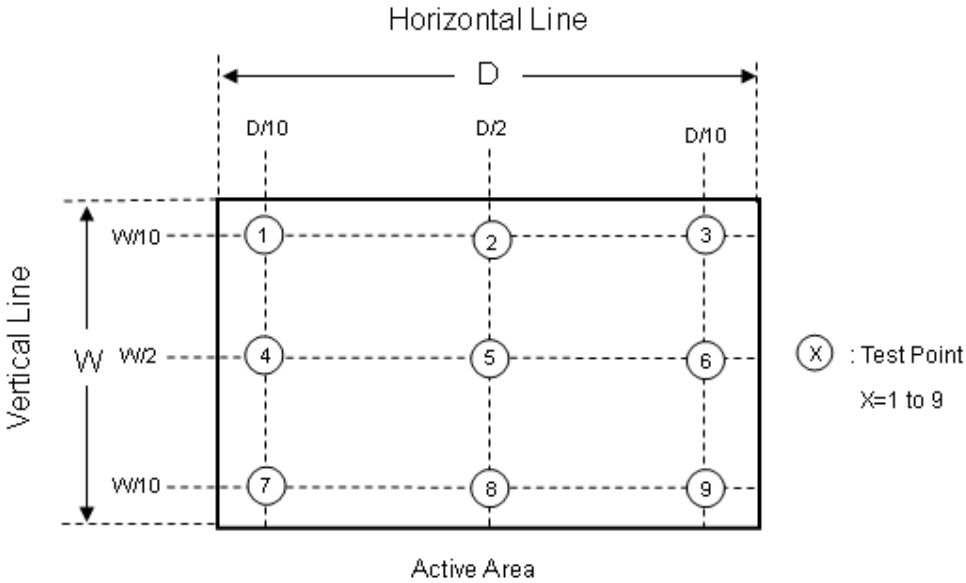

6. RELIABILITY TEST ITEM

Test Item	Test Condition	Note
High Temperature Storage Test	90°C, 240 hours	(1)(2) (4)(5)
Low Temperature Storage Test	-40°C, 240 hours	
Thermal Shock Storage Test	-30°C, 0.5hour \longleftrightarrow 85°C, 0.5hour; 1hour/cycle,100cycles	
High Temperature Operation Test	85°C, 240 hours	
Low Temperature Operation Test	-30°C, 240 hours	
High Temperature & High Humidity Operation Test	60°C, 90%RH, 240hours	(1)(2) (4)(6)
Shock (Non-Operating)	50G, 11ms, half sine wave, 1 time for $\pm X, \pm Y, \pm Z$.	(2)(3)
Vibration (Non-Operating)	1.5G, 10 ~ 300 Hz, 10min/cycle, 3 cycles each X, Y, Z	(2)(3)

Note (1) There should be no condensation on the surface of panel during test.

Note (2) Temperature of panel display surface area should be 98 °C Max.

Note (3) At testing Vibration and Shock, the fixture in holding the module has to be hard and rigid enough so that the module would not be twisted or bent by the fixture.

Note (4) In the standard conditions, there is no function failure issue occurred. All the cosmetic specification is judged before reliability test.

Note (5) Before cosmetic and function test, the product must have enough recovery time, at least 2 hours at room temperature.

Note (6) Before cosmetic and function test, the product must have enough recovery time, at least 24 hours at room temperature.

7. PACKING

7.1 PACKING SPECIFICATIONS

- (1) 18 pcs LCD modules / 1 Box
- (2) Box dimensions: 465 (L) X 362 (W) X 314 (H) mm
- (3) Weight: approximately 21.5Kg (18 modules per box)

7.2 PACKING METHOD

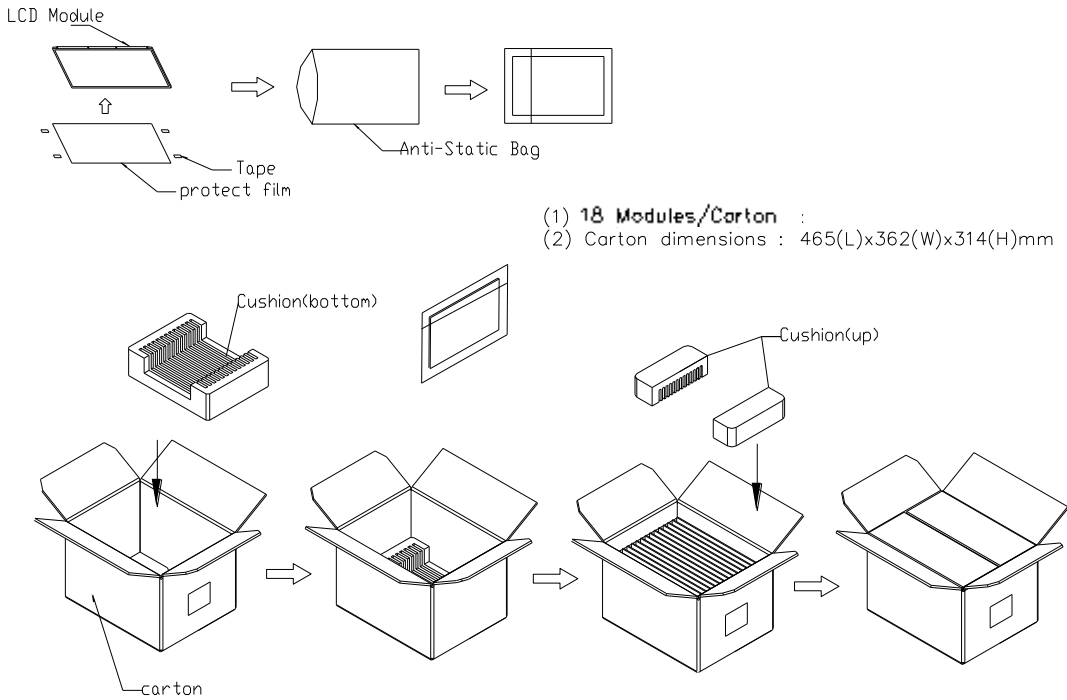

Figure. 7-1 Packing

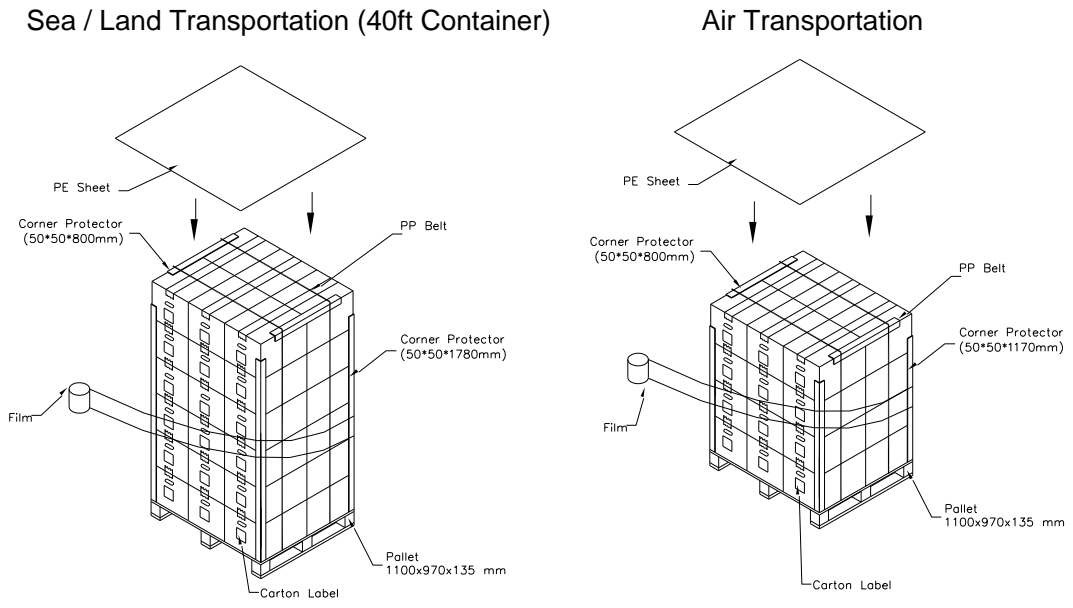

Figure. -2 Packing method

7.3 UN-PACKING METHOD

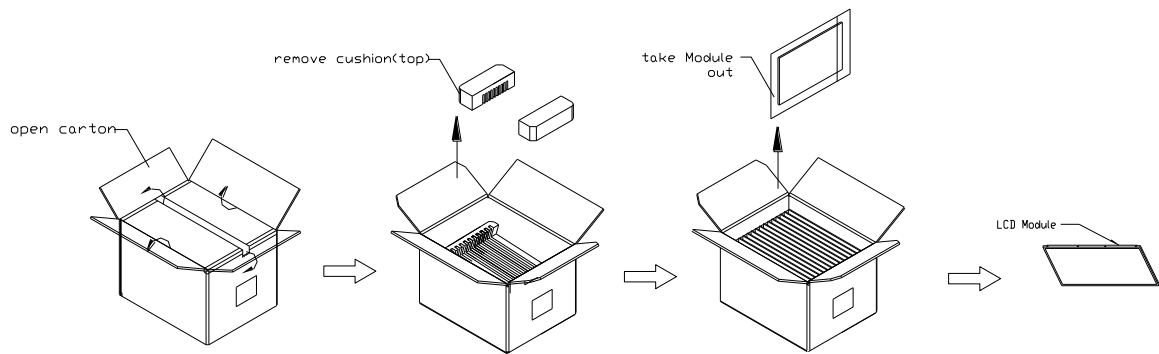

Figure. 7-3 UN-Packing method

8. MODULE LABEL

8.1 INX MODULE LABEL

The barcode nameplate is pasted on each module as illustration, and its definitions are as following explanation.



- (a) Model Name: G156HCE-L01
- (b) Revision: Rev. XX, for example: A1, B1, C1, C2 ...etc.
- (c) * * * * : Factory ID
- (d) Serial ID: X X X X X X X Y M D X N N N N

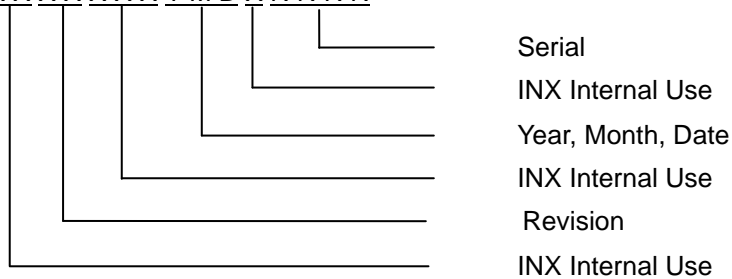

Serial ID includes the information as below:

- (a) Manufactured Date: Year: 1~9, for 2021~2029
 Month: 1~9, A~C, for Jan. ~ Dec.
 Day: 1~9, A~Y, for 1st to 31st, exclude I , O and U
- (b) Revision Code: cover all the change
- (c) Serial No.: Manufacturing sequence of product

9. PRECAUTIONS

9.1 ASSEMBLY AND HANDLING PRECAUTIONS

- (1) Do not apply rough force such as bending or twisting to the module during assembly.
- (2) To assemble or install module into user's system can be only in clean working areas. The dust and oil may cause electrical short or worsen the polarizer.
- (3) It's not permitted to have pressure or impulse on the module because the LCD panel and Backlight will be damaged.
- (4) Always follow the correct power sequence when LCD module is connecting and operating. This can prevent damage to the CMOS LSI chips during latch-up.
- (5) Do not pull the I/F connector in or out while the module is operating.
- (6) Do not disassemble the module.
- (7) Use a soft dry cloth without chemicals for cleaning, because the surface of polarizer is very soft and easily scratched.
- (8) It is dangerous that moisture come into or contacted the LCD module, because moisture may damage LCD module when it is operating.
- (9) High temperature or humidity may reduce the performance of module. Please store LCD module within the specified storage conditions.
- (10) When ambient temperature is lower than 10°C may reduce the display quality. For example, the response time will become slowly.

9.2 STORAGE PRECAUTIONS

- (1) Do not leave the module in high temperature, and high humidity for a long time. It is highly recommended to store the module with temperature from 0°C to 35°C and relative humidity of less than 70%
- (2) Do not store the TFT – LCD module in direct sunlight
- (3) The module should be stored in dark place. It is prohibited to apply sunlight or fluorescent light in storing

9.3 OPERATION PRECAUTIONS

- (1) The LCD product should be operated under normal condition.
Normal condition is defined as below :
Temperature : 20±15°C
Humidity: 65±20%
Display pattern : continually changing pattern(Not stationary)
- (2) If the product will be used in extreme conditions such as high temperature, high humidity, high altitude, display pattern or operation time etc... It is strongly recommended to contact CMI for application engineering advice. Otherwise, its reliability and function may not be guaranteed.

9.4 SAFETY PRECAUTIONS

- (1) If the liquid crystal material leaks from the panel, it should be kept away from the eyes or mouth. In case of contact with hands, skin or clothes, it has to be washed away thoroughly with soap.

(2) After the module's end of life, it is not harmful in case of normal operation and storage.

9.5 SAFETY STANDARDS

The LCD module should be certified with safety regulations as follows:

- (1) UL60950-1 or updated standard.
- (2) IEC60950-1 or updated standard.

9.6 OTHER

When fixed patterns are displayed for a long time, remnant image is likely to occur

MECHANICAL CHARACTERISTICS

